



# MINNESOTA DEPT OF TRANSPORTATION

## TRAFFIC DATA COLLECTION - METRO

TH-41 at Hundertmark Road CHASKA  
 Ref.Pt.: 004.118  
 Data by: Westwood Professional Services  
 TURN MOVEMENT COUNT

File Name : TH-41 at Hundertmark Rd 2008  
 Site Code : 22052502  
 Start Date : 10/2/2008  
 Page No : 1

### Groups Printed- Unshifted

Start Time	TH-41 Southbound				Hundertmark Rd. Westbound				TH-41 Northbound				Hundertmark Rd. Eastbound				Int. Total
	Left	Thru	Right	Peds	Left	Thru	Right	Peds	Left	Thru	Right	Peds	Left	Thru	Right	Peds	
06:00	2	31	2	0	34	2	1	1	12	98	24	0	10	15	52	0	284
06:15	1	43	4	0	35	3	2	0	12	107	25	0	26	20	63	0	341
06:30	4	101	8	0	43	12	4	0	18	163	42	0	27	24	117	0	563
06:45	2	107	5	0	45	5	3	0	25	143	44	0	31	34	89	0	533
Total	9	282	19	0	157	22	10	1	67	511	135	0	94	93	321	0	1721
07:00	3	122	15	0	47	8	2	0	27	147	68	0	20	36	116	0	611
07:15	1	104	6	0	26	11	5	0	22	191	96	0	23	45	76	0	606
07:30	1	117	3	0	41	12	7	0	30	170	124	0	23	58	83	0	669
07:45	5	105	5	0	50	20	3	0	35	164	50	0	17	49	77	0	580
Total	10	448	29	0	164	51	17	0	114	672	338	0	83	188	352	0	2466
08:00	4	96	8	0	37	13	5	0	30	154	42	0	20	35	71	0	515
08:15	4	108	2	0	51	18	5	0	33	139	29	0	20	23	74	0	506
08:30	2	115	21	0	37	12	3	0	25	163	29	0	19	27	67	0	520
08:45	2	100	8	0	22	9	5	0	28	77	28	0	39	19	49	0	386
Total	12	419	39	0	147	52	18	0	116	533	128	0	98	104	261	0	1927
*** BREAK ***																	
11:00	3	104	16	0	22	19	7	0	32	94	46	0	17	12	29	0	401
11:15	2	126	10	0	32	18	3	0	16	86	19	0	19	14	38	0	383
11:30	7	129	12	0	24	10	2	0	21	53	28	1	16	15	30	0	348
11:45	2	135	23	0	30	14	8	0	11	126	40	0	15	18	30	0	452
Total	14	494	61	0	108	61	20	0	80	359	133	1	67	59	127	0	1584
12:00	3	131	20	0	37	12	5	0	13	143	37	0	21	15	34	0	471
12:15	2	134	20	0	33	27	4	0	32	114	45	0	23	22	24	0	480
12:30	6	128	18	0	29	22	4	0	32	134	43	0	21	20	42	0	499
12:45	3	139	14	0	36	26	8	1	31	122	42	0	18	16	21	0	477
Total	14	532	72	0	135	87	21	1	108	513	167	0	83	73	121	0	1927
*** BREAK ***																	
15:00	4	155	27	0	50	22	8	0	48	123	70	0	16	28	52	0	603
15:15	2	163	23	0	60	42	8	0	59	150	61	0	11	13	43	0	635
15:30	2	167	19	0	56	36	4	0	56	129	68	0	17	22	64	0	640
15:45	6	166	28	0	59	31	7	0	69	183	73	0	22	16	53	0	713
Total	14	651	97	0	225	131	27	0	232	585	272	0	66	79	212	0	2591
16:00	0	156	16	0	51	40	5	0	75	145	86	0	35	17	63	0	689
16:15	3	160	18	0	46	37	2	0	74	149	62	0	21	34	51	0	657
16:30	2	176	19	0	51	47	10	0	100	168	80	0	22	40	49	0	764
16:45	2	189	26	0	49	50	6	0	89	178	94	0	22	40	40	0	785
Total	7	681	79	0	197	174	23	0	338	640	322	0	100	131	203	0	2895
17:00	2	191	17	0	56	30	2	0	83	145	82	0	32	18	51	0	709
17:15	2	162	35	0	51	48	4	0	86	181	115	0	24	44	51	0	803
17:30	8	188	26	0	76	61	9	0	73	189	95	0	39	32	41	0	837
17:45	1	191	45	0	73	70	6	0	79	194	73	0	34	33	46	0	845
Total	13	732	123	0	256	209	21	0	321	709	365	0	129	127	189	0	3194
Grand Total	93	4239	519	0	1389	787	157	2	1376	4522	1860	1	720	854	1786	0	18305
Apprch %	1.9	87.4	10.7	0	59.5	33.7	6.7	0.1	17.7	58.3	24	0	21.4	25.4	53.2	0	
Total %	0.5	23.2	2.8	0	7.6	4.3	0.9	0	7.5	24.7	10.2	0	3.9	4.7	9.8	0	



# MINNESOTA DEPT OF TRANSPORTATION

## TRAFFIC DATA COLLECTION - METRO

TH-41 at Hundertmark Road CHASKA  
 Ref.Pt.: 004.118  
 Data by: Westwood Professional Services  
 TURN MOVEMENT COUNT

File Name : TH-41 at Hundertmark Rd 2008  
 Site Code : 22052502  
 Start Date : 10/2/2008  
 Page No : 2

Start Time	TH-41 Southbound					Hundertmark Rd. Westbound					TH-41 Northbound					Hundertmark Rd. Eastbound					Int. Total
	Left	Thru	Right	Peds	App. Total	Left	Thru	Right	Peds	App. Total	Left	Thru	Right	Peds	App. Total	Left	Thru	Right	Peds	App. Total	
Peak Hour Analysis From 06:00 to 08:45 - Peak 1 of 1																					
Peak Hour for Entire Intersection Begins at 07:00																					
07:00	3	122	15	0	140	47	8	2	0	57	27	147	68	0	242	20	36	116	0	172	611
07:15	1	104	6	0	111	26	11	5	0	42	22	191	96	0	309	23	45	76	0	144	606
07:30	1	117	3	0	121	41	12	7	0	60	30	170	124	0	324	23	58	83	0	164	669
07:45	5	105	5	0	115	50	20	3	0	73	35	164	50	0	249	17	49	77	0	143	580
Total Volume	10	448	29	0	487	164	51	17	0	232	114	672	338	0	1124	83	188	352	0	623	2466
% App. Total	2.1	92	6	0		70.7	22	7.3	0		10.1	59.8	30.1	0		13.3	30.2	56.5	0		
PHF	.500	.918	.483	.000	.870	.820	.638	.607	.000	.795	.814	.880	.681	.000	.867	.902	.810	.759	.000	.906	.922

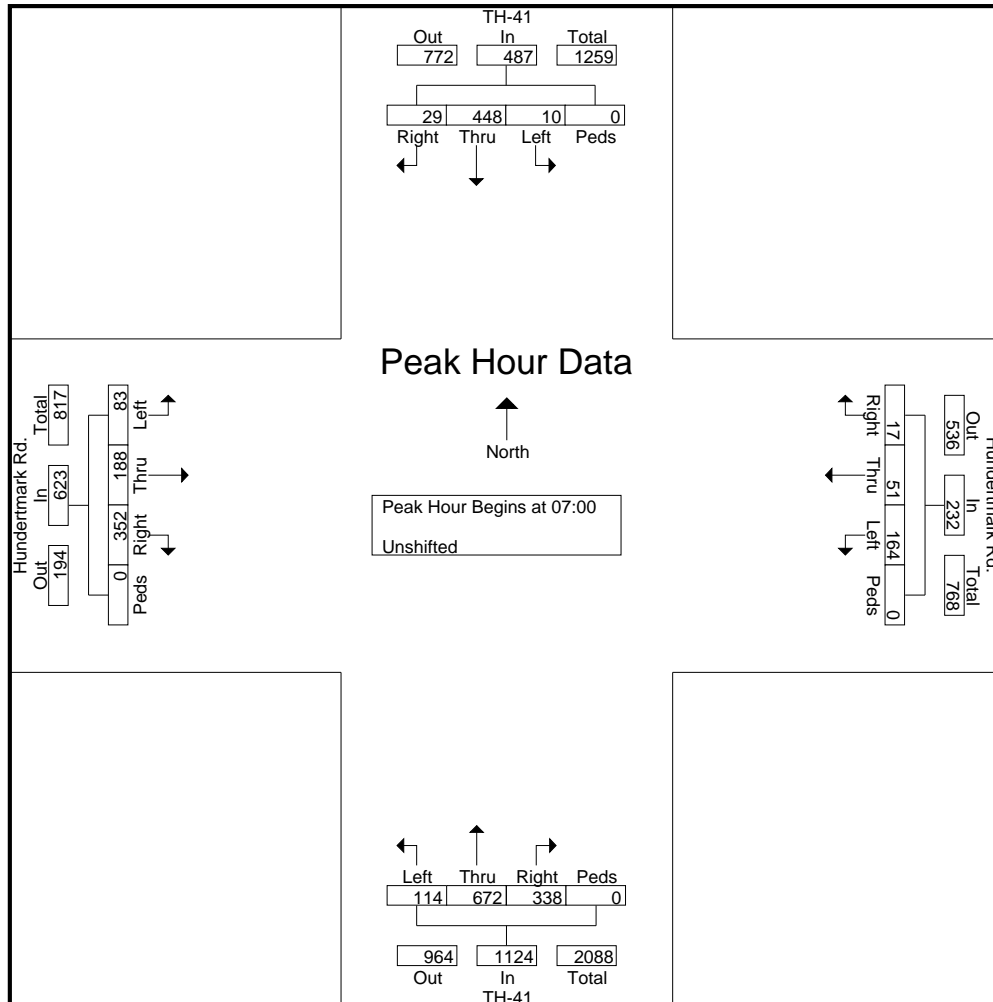



# MINNESOTA DEPT OF TRANSPORTATION

## TRAFFIC DATA COLLECTION - METRO

TH-41 at Hundertmark Road CHASKA  
 Ref.Pt.: 004.118  
 Data by: Westwood Professional Services  
 TURN MOVEMENT COUNT

File Name : TH-41 at Hundertmark Rd 2008  
 Site Code : 22052502  
 Start Date : 10/2/2008  
 Page No : 3

Start Time	TH-41 Southbound					Hundertmark Rd. Westbound					TH-41 Northbound					Hundertmark Rd. Eastbound					Int. Total
	Left	Thru	Right	Peds	App. Total	Left	Thru	Right	Peds	App. Total	Left	Thru	Right	Peds	App. Total	Left	Thru	Right	Peds	App. Total	

Peak Hour Analysis From 15:00 to 17:45 - Peak 1 of 1  
 Peak Hour for Entire Intersection Begins at 17:00

17:00	2	191	17	0	210	56	30	2	0	88	83	145	82	0	310	32	18	51	0	101	709
17:15	2	162	35	0	199	51	48	4	0	103	86	181	115	0	382	24	44	51	0	119	803
17:30	8	188	26	0	222	76	61	9	0	146	73	189	95	0	357	39	32	41	0	112	837
17:45	1	191	45	0	237	73	70	6	0	149	79	194	73	0	346	34	33	46	0	113	845
Total Volume	13	732	123	0	868	256	209	21	0	486	321	709	365	0	1395	129	127	189	0	445	3194
% App. Total	1.5	84.3	14.2	0		52.7	43	4.3	0		23	50.8	26.2	0		29	28.5	42.5	0		
PHF	.406	.958	.683	.000	.916	.842	.746	.583	.000	.815	.933	.914	.793	.000	.913	.827	.722	.926	.000	.935	.945

