



MINNESOTA DEPT OF TRANSPORTATION

TRAFFIC DATA COLLECTION - METRO

TH-41 at TH-212, south ramps CHASKA
 Ref.Pt.,: 002.926
 video SP/RE
 TURN MOVEMENT COUNT

File Name : TH-41 at TH-212 south ramp 2013
 Site Code :
 Start Date : 11/13/2013
 Page No : 1

Groups Printed- Cars +

Start Time	TH-41 Southbound			ramp to TH-212 EB Westbound				TH-41 Northbound			ramp from TH-212 EB Eastbound				Int. Total
	Thru	Left	Peds	Right	Thru	Left	Peds	Right	Thru	Peds	Right	Thru	Left	Peds	
06:00	19	17	0	0	0	0	0	16	12	0	3	0	20	0	87
06:15	23	33	0	0	0	0	0	33	21	0	1	0	32	0	143
06:30	19	51	0	0	0	0	0	48	44	0	5	0	42	0	209
06:45	36	55	0	0	0	0	0	55	53	0	2	0	47	0	248
Total	97	156	0	0	0	0	0	152	130	0	11	0	141	0	687
07:00	60	72	0	0	0	0	0	50	40	0	14	0	32	0	268
07:15	76	88	0	0	0	0	0	62	76	0	20	0	50	0	372
07:30	105	133	0	0	0	0	0	108	101	0	23	0	60	0	530
07:45	117	138	0	0	0	0	0	141	178	0	19	0	92	0	685
Total	358	431	0	0	0	0	0	361	395	0	76	0	234	0	1855
08:00	152	166	0	0	0	0	0	110	135	0	21	0	78	0	662
08:15	192	111	0	0	0	0	0	127	200	0	42	0	97	0	769
08:30	144	146	0	0	0	0	0	108	143	0	14	0	96	0	651
08:45	148	98	0	0	0	0	0	115	170	0	13	0	115	0	659
Total	636	521	0	0	0	0	0	460	648	0	90	0	386	0	2741
***** BREAK *****															
11:00	117	56	0	0	0	0	0	34	76	0	4	0	21	0	308
11:15	97	49	0	0	0	0	0	53	104	0	3	0	26	0	332
11:30	104	46	0	0	0	0	0	49	103	0	0	0	16	0	318
11:45	116	45	0	0	0	0	0	35	91	0	7	0	29	0	323
Total	434	196	0	0	0	0	0	171	374	0	14	0	92	0	1281
12:00	122	52	0	0	0	0	0	39	90	0	5	0	20	0	328
12:15	128	49	0	0	0	0	0	36	101	0	2	0	28	0	344
12:30	139	47	0	0	0	0	0	38	95	0	2	0	30	0	351
12:45	124	39	0	0	0	0	0	42	122	0	4	0	31	0	362
Total	513	187	0	0	0	0	0	155	408	0	13	0	109	0	1385
***** BREAK *****															
15:00	147	50	0	0	0	0	0	37	121	0	2	1	26	0	384
15:15	169	41	0	0	0	0	0	56	147	0	9	0	23	0	445
15:30	164	34	0	0	0	0	0	64	127	0	2	0	24	0	415
15:45	184	53	0	0	0	0	0	55	143	0	3	0	37	0	475
Total	664	178	0	0	0	0	0	212	538	0	16	1	110	0	1719
16:00	171	36	0	0	0	0	0	38	133	0	8	0	21	0	407
16:15	236	52	0	0	0	0	0	48	137	0	2	0	38	0	513
16:30	257	58	0	0	0	0	0	59	130	0	8	0	44	0	556
16:45	268	53	0	0	0	0	0	42	153	0	3	0	22	0	541
Total	932	199	0	0	0	0	0	187	553	0	21	0	125	0	2017
17:00	246	61	0	0	0	0	0	60	188	0	7	0	20	0	582
17:15	270	56	0	0	0	0	0	46	137	0	2	0	26	0	537
17:30	264	57	0	0	0	0	0	65	190	0	4	0	29	0	609
17:45	261	60	0	0	0	0	0	56	160	0	3	0	38	0	578
Total	1041	234	0	0	0	0	0	227	675	0	16	0	113	0	2306
Grand Total	4675	2102	0	0	0	0	0	1925	3721	0	257	1	1310	0	13991
Apprch %	69	31	0	0	0	0	0	34.1	65.9	0	16.4	0.1	83.5	0	
Total %	33.4	15	0	0	0	0	0	13.8	26.6	0	1.8	0	9.4	0	



MINNESOTA DEPT OF TRANSPORTATION

TRAFFIC DATA COLLECTION - METRO

TH-41 at TH-212, south ramps CHASKA
 Ref.Pt.,: 002.926
 video SP/RE
 TURN MOVEMENT COUNT

File Name : TH-41 at TH-212 south ramp 2013
 Site Code :
 Start Date : 11/13/2013
 Page No : 2

Start Time	TH-41 Southbound				ramp to TH-212 EB Westbound					TH-41 Northbound				ramp from TH-212 EB Eastbound					Int. Total
	Thru	Left	Peds	App. Total	Right	Thru	Left	Peds	App. Total	Right	Thru	Peds	App. Total	Right	Thru	Left	Peds	App. Total	
Peak Hour Analysis From 06:00 to 08:45 - Peak 1 of 1																			
Peak Hour for Entire Intersection Begins at 07:45																			
07:45	117	138	0	255	0	0	0	0	0	141	178	0	319	19	0	92	0	111	685
08:00	152	166	0	318	0	0	0	0	0	110	135	0	245	21	0	78	0	99	662
08:15	192	111	0	303	0	0	0	0	0	127	200	0	327	42	0	97	0	139	769
08:30	144	146	0	290	0	0	0	0	0	108	143	0	251	14	0	96	0	110	651
Total Volume	605	561	0	1166	0	0	0	0	0	486	656	0	1142	96	0	363	0	459	2767
% App. Total	51.9	48.1	0		0	0	0	0		42.6	57.4	0		20.9	0	79.1	0		
PHF	.788	.845	.000	.917	.000	.000	.000	.000	.000	.862	.820	.000	.873	.571	.000	.936	.000	.826	.900

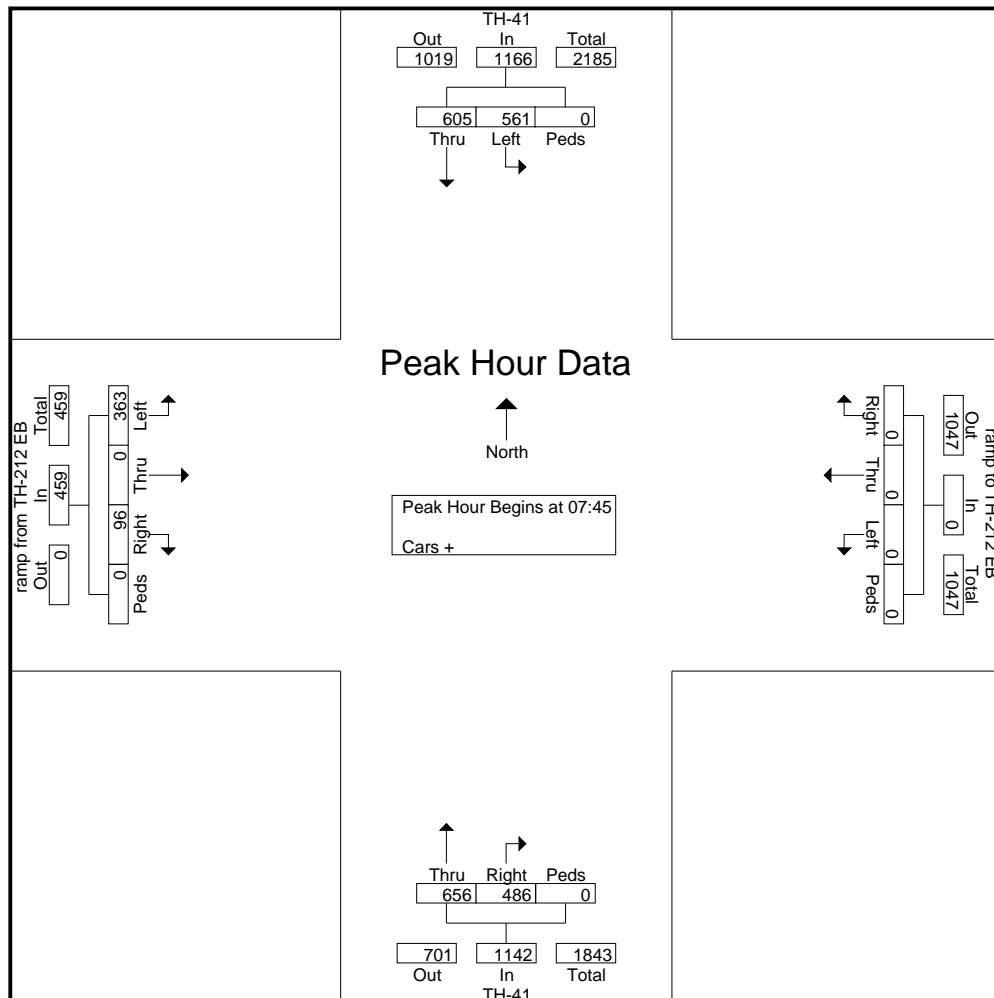



MINNESOTA DEPT OF TRANSPORTATION

TRAFFIC DATA COLLECTION - METRO

TH-41 at TH-212, south ramps CHASKA
 Ref.Pt.,: 002.926
 video SP/RE
 TURN MOVEMENT COUNT

File Name : TH-41 at TH-212 south ramp 2013
 Site Code :
 Start Date : 11/13/2013
 Page No : 3

Start Time	TH-41 Southbound				ramp to TH-212 EB Westbound					TH-41 Northbound				ramp from TH-212 EB Eastbound					Int. Total
	Thru	Left	Peds	App. Total	Right	Thru	Left	Peds	App. Total	Right	Thru	Peds	App. Total	Right	Thru	Left	Peds	App. Total	
17:00	246	61	0	307	0	0	0	0	0	60	188	0	248	7	0	20	0	27	582
17:15	270	56	0	326	0	0	0	0	0	46	137	0	183	2	0	26	0	28	537
17:30	264	57	0	321	0	0	0	0	0	65	190	0	255	4	0	29	0	33	609
17:45	261	60	0	321	0	0	0	0	0	56	160	0	216	3	0	113	0	41	578
Total Volume	1041	234	0	1275	0	0	0	0	0	227	675	0	902	16	0	113	0	129	2306
% App. Total	81.6	18.4	0		0	0	0	0	0	25.2	74.8	0		12.4	0	87.6	0		
PHF	.964	.959	.000	.978	.000	.000	.000	.000	.000	.873	.888	.000	.884	.571	.000	.743	.000	.787	.947

Peak Hour Analysis From 15:00 to 17:45 - Peak 1 of 1
 Peak Hour for Entire Intersection Begins at 17:00

