

**Alliant Engineering, Inc**

733 Marquette Ave, Ste 700

Minneapolis, MN 55402

--TRAFFIC DATA--

CSAH 5 & Orleans-Wild Pines  
 No Ref Point  
 Data by: Alliant Engineering, Inc.  
 TURN MOVEMENT COUNT

File Name : 705\_CSAH 5 & Orleans-Wild Pines  
 Site Code : 705  
 Start Date : 5/16/2018  
 Page No : 1

Groups Printed- Cars - Trucks

Start Time	CSAH 5 Southbound					Orleans St Westbound					CSAH 5 Northbound					Wild Pines Ln Eastbound					Int. Total
	Peds	Right	Thru	Left	App. Total	Peds	Right	Thru	Left	App. Total	Peds	Right	Thru	Left	App. Total	Peds	Right	Thru	Left	App. Total	
06:00 AM	0	0	76	15	91	0	5	0	16	21	1	9	16	0	26	0	14	7	0	21	159
06:15 AM	0	0	74	22	96	0	7	1	16	24	2	11	19	1	33	0	18	2	0	20	173
06:30 AM	1	0	88	20	109	0	5	0	11	16	0	13	29	2	44	0	23	6	0	29	198
06:45 AM	0	1	129	30	160	0	11	0	23	34	0	19	33	1	53	0	17	3	0	20	267
Total	1	1	367	87	456	0	28	1	66	95	3	52	97	4	156	0	72	18	0	90	797
07:00 AM	0	0	190	37	227	0	10	0	29	39	0	13	37	3	53	0	24	9	0	33	352
07:15 AM	0	2	233	35	270	0	25	2	23	50	0	28	61	4	93	0	36	14	0	50	463
07:30 AM	0	1	155	29	185	0	14	5	14	33	0	31	92	6	129	0	24	8	3	35	382
07:45 AM	0	2	131	43	176	0	22	2	24	48	1	25	69	4	99	0	19	12	3	34	357
Total	0	5	709	144	858	0	71	9	90	170	1	97	259	17	374	0	103	43	6	152	1554
08:00 AM	0	1	135	41	177	0	21	0	17	38	0	16	73	6	95	1	8	4	0	13	323
08:15 AM	0	2	128	39	169	0	26	2	26	54	0	22	71	2	95	0	15	4	0	19	337
08:30 AM	0	1	127	47	175	0	30	1	19	50	0	17	70	3	90	0	13	7	2	22	337
08:45 AM	0	1	127	44	172	0	18	5	24	47	0	14	80	6	100	0	13	8	1	22	341
Total	0	5	517	171	693	0	95	8	86	189	0	69	294	17	380	1	49	23	3	76	1338
09:00 AM	0	2	127	37	166	1	29	3	18	51	0	17	76	4	97	0	13	6	0	19	333
09:15 AM	0	0	88	35	123	0	21	2	29	52	0	23	68	4	95	0	10	5	0	15	285
*** BREAK ***																					
Total	0	2	215	72	289	1	50	5	47	103	0	40	144	8	192	0	23	11	0	34	618
*** BREAK ***																					
10:30 AM	0	2	92	17	111	0	37	6	24	67	0	31	78	8	117	1	9	3	1	14	309
10:45 AM	0	0	87	32	119	1	41	4	14	60	0	27	85	4	116	0	12	7	1	20	315
Total	0	2	179	49	230	1	78	10	38	127	0	58	163	12	233	1	21	10	2	34	624
11:00 AM	1	1	97	28	127	0	38	3	14	55	0	15	85	11	111	2	12	2	1	17	310
11:15 AM	0	0	94	25	119	0	36	4	22	62	0	21	92	2	115	0	11	9	0	20	316
11:30 AM	0	0	92	33	125	1	35	5	16	57	0	26	94	7	127	1	11	4	1	17	326
11:45 AM	0	1	87	36	124	0	35	6	24	65	0	21	108	4	133	0	10	5	1	16	338
Total	1	2	370	122	495	1	144	18	76	239	0	83	379	24	486	3	44	20	3	70	1290
12:00 PM	0	1	90	36	127	0	56	8	23	87	0	22	102	9	133	1	5	6	0	12	359
12:15 PM	1	1	79	42	123	0	49	6	28	83	0	26	95	5	126	0	5	5	2	12	344
12:30 PM	0	1	80	29	110	0	56	5	28	89	0	18	115	9	142	0	11	6	0	17	358
12:45 PM	0	1	93	20	114	0	48	9	16	73	0	27	114	4	145	0	6	6	0	12	344
Total	1	4	342	127	474	0	209	28	95	332	0	93	426	27	546	1	27	23	2	53	1405
01:00 PM	0	0	95	33	128	0	50	3	22	75	0	22	96	8	126	0	10	5	0	15	344
01:15 PM	0	0	84	34	118	1	44	4	23	72	0	38	125	10	173	0	12	7	3	22	385
*** BREAK ***																					
Total	0	0	179	67	246	1	94	7	45	147	0	60	221	18	299	0	22	12	3	37	729
*** BREAK ***																					
02:30 PM	1	2	100	34	137	0	48	5	15	68	4	21	141	8	174	1	13	9	0	23	402
02:45 PM	1	1	105	30	137	1	37	10	20	68	2	31	132	9	174	0	16	3	2	21	400
Total	2	3	205	64	274	1	85	15	35	136	6	52	273	17	348	1	29	12	2	44	802
03:00 PM	0	0	128	36	164	0	52	10	17	79	0	30	138	7	175	1	8	4	1	14	432
03:15 PM	0	0	106	29	135	1	41	12	21	75	1	26	141	8	176	0	14	4	0	18	404

**Alliant Engineering, Inc**

733 Marquette Ave, Ste 700

Minneapolis, MN 55402

--TRAFFIC DATA--

File Name : 705\_CSAH 5 & Orleans-Wild Pines

Site Code : 705

Start Date : 5/16/2018

Page No : 2

Groups Printed- Cars - Trucks

Start Time	CSAH 5 Southbound					Orleans St Westbound					CSAH 5 Northbound					Wild Pines Ln Eastbound					Int. Total
	Peds	Right	Thru	Left	App. Total	Peds	Right	Thru	Left	App. Total	Peds	Right	Thru	Left	App. Total	Peds	Right	Thru	Left	App. Total	
03:30 PM	1	0	121	32	154	0	42	9	20	71	0	20	130	7	157	0	5	6	0	11	393
03:45 PM	2	0	130	36	168	0	45	13	18	76	2	30	150	15	197	2	7	7	1	17	458
Total	3	0	485	133	621	1	180	44	76	301	3	106	559	37	705	3	34	21	2	60	1687
04:00 PM	0	0	111	32	143	1	72	7	35	115	4	26	173	12	215	0	9	8	1	18	491
04:15 PM	0	0	133	31	164	0	62	14	24	100	0	45	181	15	241	0	11	10	1	22	527
04:30 PM	0	1	141	38	180	0	69	13	31	113	1	27	165	11	204	0	10	6	3	19	516
04:45 PM	2	1	105	40	148	1	56	14	26	97	0	27	179	14	220	0	16	2	1	19	484
Total	2	2	490	141	635	2	259	48	116	425	5	125	698	52	880	0	46	26	6	78	2018
05:00 PM	0	1	144	39	184	0	79	10	29	118	0	29	204	19	252	0	19	11	0	30	584
05:15 PM	0	0	121	42	163	0	50	11	16	77	0	34	186	13	233	1	15	4	2	22	495
05:30 PM	1	0	132	41	174	0	65	8	27	100	2	28	184	12	226	1	13	1	0	15	515
05:45 PM	1	2	114	34	151	0	68	6	18	92	0	31	198	16	245	0	17	7	2	26	514
Total	2	3	511	156	672	0	262	35	90	387	2	122	772	60	956	2	64	23	4	93	2108

\*\*\* BREAK \*\*\*

Grand Total	12	29	4569	1333	5943	8	1555	228	860	2651	20	957	4285	293	5555	12	534	242	33	821	14970
Apprch %	0.2	0.5	76.9	22.4		0.3	58.7	8.6	32.4		0.4	17.2	77.1	5.3		1.5	65	29.5	4		
Total %	0.1	0.2	30.5	8.9	39.7	0.1	10.4	1.5	5.7	17.7	0.1	6.4	28.6	2	37.1	0.1	3.6	1.6	0.2	5.5	
Cars	4	24	4457	1303	5788	4	1529	219	817	2569	10	910	4152	277	5349	9	507	234	32	782	14488
% Cars	33.3	82.8	97.5	97.7	97.4	50	98.3	96.1	95	96.9	50	95.1	96.9	94.5	96.3	75	94.9	96.7	97	95.2	96.8
Trucks	8	5	112	30	155	4	26	9	43	82	10	47	133	16	206	3	27	8	1	39	482
% Trucks	66.7	17.2	2.5	2.3	2.6	50	1.7	3.9	5	3.1	50	4.9	3.1	5.5	3.7	25	5.1	3.3	3	4.8	3.2

**Alliant Engineering, Inc**

733 Marquette Ave, Ste 700

Minneapolis, MN 55402

--TRAFFIC DATA--

File Name : 705\_CSAH 5 & Orleans-Wild Pines

Site Code : 705

Start Date : 5/16/2018

Page No : 3

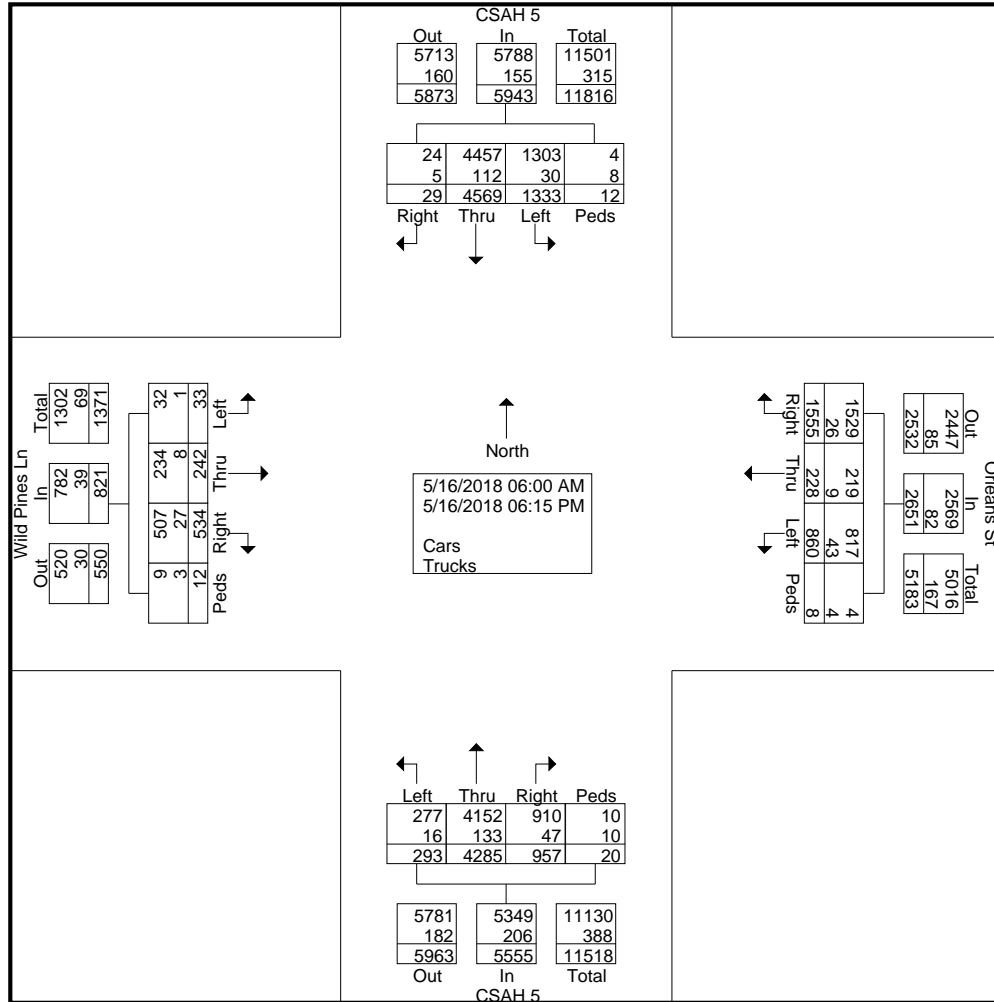

Start Time	CSAH 5 Southbound					Orleans St Westbound					CSAH 5 Northbound					Wild Pines Ln Eastbound					Int. Total
	Peds	Right	Thru	Left	App. Total	Peds	Right	Thru	Left	App. Total	Peds	Right	Thru	Left	App. Total	Peds	Right	Thru	Left	App. Total	
Peak Hour Analysis From 06:00 AM to 11:45 AM - Peak 1 of 1																					
Peak Hour for Entire Intersection Begins at 07:00 AM																					
07:00 AM	0	0	190	37	227	0	10	0	<b>29</b>	39	0	13	37	3	53	0	24	9	0	33	352
07:15 AM	0	<b>2</b>	<b>233</b>	35	<b>270</b>	0	<b>25</b>	2	23	<b>50</b>	0	28	61	4	93	0	<b>36</b>	<b>14</b>	0	<b>50</b>	<b>463</b>
07:30 AM	0	1	155	29	185	0	14	5	14	33	0	<b>31</b>	<b>92</b>	<b>6</b>	<b>129</b>	0	24	8	<b>3</b>	35	382
07:45 AM	0	2	131	<b>43</b>	176	0	22	2	24	48	<b>1</b>	25	69	4	99	0	19	12	3	34	357
Total Volume	0	5	709	144	858	0	71	9	90	170	1	97	259	17	374	0	103	43	6	152	1554
% App. Total	0	0.6	82.6	16.8		0	41.8	5.3	52.9		0.3	25.9	69.3	4.5		0	67.8	28.3	3.9		
PHF	.000	.625	.761	.837	.794	.000	.710	.450	.776	.850	.250	.782	.704	.708	.725	.000	.715	.768	.500	.760	.839

**Alliant Engineering, Inc**

733 Marquette Ave, Ste 700

Minneapolis, MN 55402

--TRAFFIC DATA--

File Name : 705\_CSAH 5 & Orleans-Wild Pines

Site Code : 705

Start Date : 5/16/2018

Page No : 4

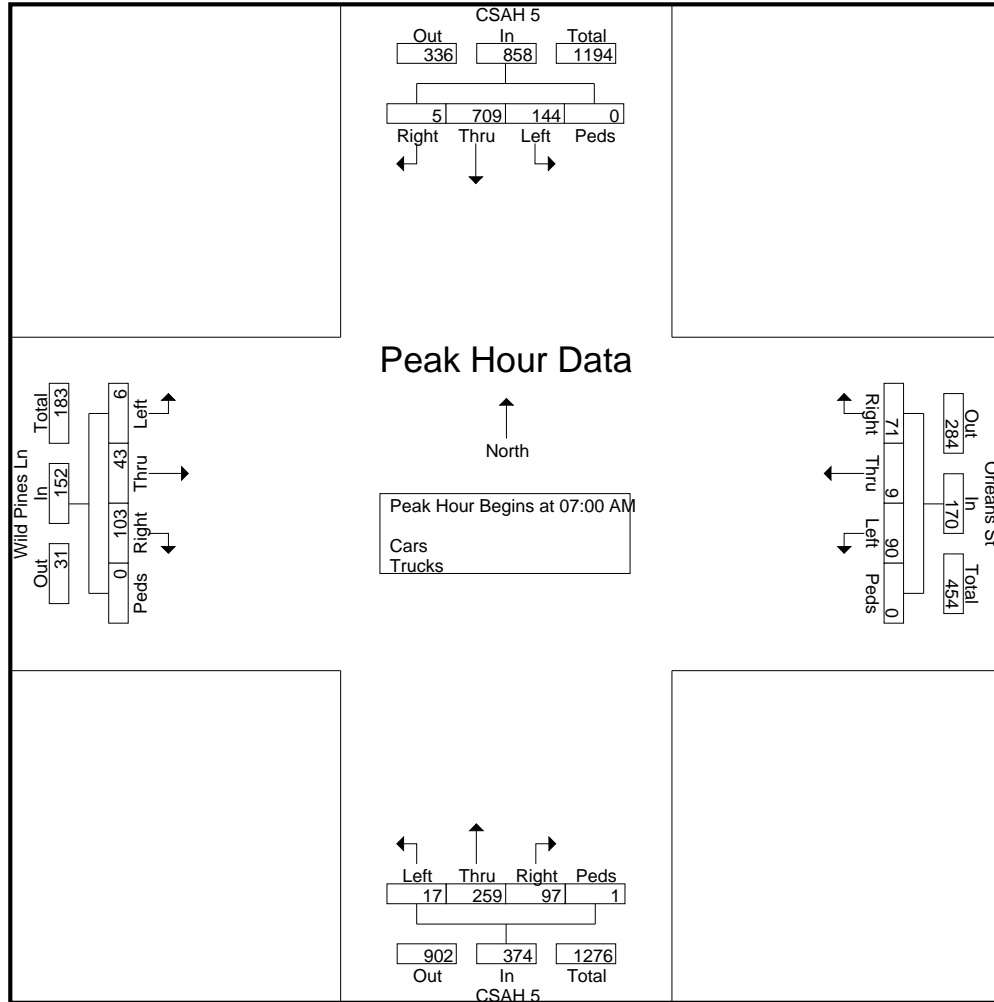

Peak Hour Analysis From 12:00 PM to 06:15 PM - Peak 1 of 1

Peak Hour for Entire Intersection Begins at 04:15 PM

04:15 PM	0	0	133	31	164	0	62	14	24	100	0	45	181	15	241	0	11	10	1	22	527
04:30 PM	0	1	141	38	180	0	69	13	31	113	1	27	165	11	204	0	10	6	3	19	516
04:45 PM	2	1	105	40	148	1	56	14	26	97	0	27	179	14	220	0	16	2	1	19	484
05:00 PM	0	1	144	39	184	0	79	10	29	118	0	29	204	19	252	0	19	11	0	30	584
Total Volume	2	3	523	148	676	1	266	51	110	428	1	128	729	59	917	0	56	29	5	90	2111
% App. Total	0.3	0.4	77.4	21.9		0.2	62.1	11.9	25.7		0.1	14	79.5	6.4		0	62.2	32.2	5.6		
PHF	.250	.750	.908	.925	.918	.250	.842	.911	.887	.907	.250	.711	.893	.776	.910	.000	.737	.659	.417	.750	.904

**Alliant Engineering, Inc**

733 Marquette Ave, Ste 700

Minneapolis, MN 55402

--TRAFFIC DATA--

File Name : 705\_CSAH 5 & Orleans-Wild Pines

Site Code : 705

Start Date : 5/16/2018

Page No : 5

