



MINNESOTA DEPT OF TRANSPORTATION

TRAFFIC DATA COLLECTION - METRO

TH-952 / ROBERT ST. at ANNAPOLIS ST.

REF.PT.: 129.507

JAMAR# 631 RE

TURN MOVEMENT COUNT

File Name : TH-952 AT ANNAPOLIS ST

Site Code : 00000000

Start Date : 2/22/2006

Page No : 1

Groups Printed- Cars & Trucks

Start Time	TH-952 / ROBERT ST. Southbound				ANNAPOLIS ST. Westbound				TH-952 / ROBERT ST. Northbound				ANNAPOLIS ST. Eastbound				Int. Total
	Left	Thru	Right	Peds	Left	Thru	Right	Peds	Left	Thru	Right	Peds	Left	Thru	Right	Peds	
06:00	1	13	4	0	0	4	4	0	1	33	0	0	5	2	4	0	71
06:15	1	19	3	0	0	2	4	0	5	49	0	0	9	1	9	1	103
06:30	0	30	6	0	2	2	7	0	9	82	0	1	10	3	10	0	162
06:45	1	38	7	0	3	14	5	0	5	117	2	2	9	8	6	1	218
Total	3	100	20	0	5	22	20	0	20	281	2	3	33	14	29	2	554
07:00	2	44	5	0	2	13	13	0	12	124	3	1	15	4	13	0	251
07:15	1	56	9	0	5	10	11	2	10	130	2	0	21	11	15	1	284
07:30	3	51	4	0	2	17	12	1	16	117	4	0	18	9	14	2	270
07:45	1	60	5	0	4	11	19	0	12	147	1	0	10	13	20	1	304
Total	7	211	23	0	13	51	55	3	50	518	10	1	64	37	62	4	1109
08:00	2	49	5	0	7	8	3	0	14	117	2	0	23	6	10	1	247
08:15	3	58	4	0	2	12	16	0	15	101	4	0	12	15	8	0	250
08:30	2	58	4	1	3	7	8	0	14	91	0	0	12	6	9	1	216
08:45	3	73	6	0	3	14	5	1	15	84	3	2	9	6	19	1	244
Total	10	238	19	1	15	41	32	1	58	393	9	2	56	33	46	3	957
10:30	2	91	4	2	3	5	1	0	7	106	3	0	15	10	15	0	264
10:45	3	77	4	0	11	8	2	1	20	84	8	1	7	4	17	0	247
Total	5	168	8	2	14	13	3	1	27	190	11	1	22	14	32	0	511
11:00	0	103	7	0	2	5	4	0	16	75	8	1	9	5	21	0	256
11:15	2	104	10	5	6	6	2	0	11	98	2	2	4	3	13	3	271
11:30	1	120	12	3	8	9	6	1	10	114	11	1	9	5	5	1	316
11:45	2	131	6	2	5	6	5	0	15	108	5	1	6	7	20	0	319
Total	5	458	35	10	21	26	17	1	52	395	26	5	28	20	59	4	1162
12:00	2	148	15	1	8	8	3	3	19	137	2	2	9	5	16	2	380
12:15	5	140	9	1	5	7	7	1	11	142	4	0	8	6	17	0	363
12:30	2	141	7	2	2	6	6	0	20	128	3	1	6	10	15	1	350
12:45	1	143	9	0	2	2	3	1	18	161	2	0	8	4	18	0	372
Total	10	572	40	4	17	23	19	5	68	568	11	3	31	25	66	3	1465
14:30	4	119	12	2	5	10	5	0	16	118	8	0	6	7	25	1	338
14:45	3	133	13	0	3	14	4	0	19	135	4	0	12	9	28	2	379
Total	7	252	25	2	8	24	9	0	35	253	12	0	18	16	53	3	717
15:00	7	148	6	0	5	14	3	1	29	118	5	3	15	19	14	0	387
15:15	5	127	10	2	4	20	4	0	16	137	11	1	8	13	23	5	386
15:30	8	166	13	1	3	9	3	1	31	132	3	0	11	14	26	3	424
15:45	6	161	20	0	6	12	3	0	26	123	3	0	12	13	27	2	414
Total	26	602	49	3	18	55	13	2	102	510	22	4	46	59	90	10	1611
16:00	4	153	20	1	8	11	4	0	30	119	6	1	9	11	24	1	402
16:15	1	147	14	0	2	14	5	3	20	130	6	0	13	17	22	5	399
16:30	6	125	11	0	12	21	9	1	24	140	5	1	8	13	24	2	402
16:45	9	190	18	2	2	13	2	4	26	137	4	2	11	13	17	4	454
Total	20	615	63	3	24	59	20	8	100	526	21	4	41	54	87	12	1657
17:00	5	179	18	0	6	11	8	1	29	121	6	0	14	14	38	3	453
17:15	8	187	10	1	5	13	5	2	34	123	8	0	9	17	23	3	448
17:30	7	136	10	4	6	11	8	4	28	119	7	4	8	17	31	1	401
17:45	0	142	11	3	9	7	3	0	33	132	12	4	8	12	19	3	398
Total	20	644	49	8	26	42	24	7	124	495	33	8	39	60	111	10	1700



MINNESOTA DEPT OF TRANSPORTATION

TRAFFIC DATA COLLECTION - METRO

TH-952 / ROBERT ST. at ANNAPOLIS ST.

File Name : TH-952 AT ANNAPOLIS ST

REF.PT.: 129.507

Site Code : 00000000

JAMAR# 631 RE

Start Date : 2/22/2006

TURN MOVEMENT COUNT

Page No : 2

Groups Printed- Cars & Trucks

Start Time	TH-952 / ROBERT ST. Southbound				ANNAPOLIS ST. Westbound				TH-952 / ROBERT ST. Northbound				ANNAPOLIS ST. Eastbound				Int. Total
	Left	Thru	Right	Peds	Left	Thru	Right	Peds	Left	Thru	Right	Peds	Left	Thru	Right	Peds	
Grand Total	113	3860	331	33	161	356	212	28	636	4129	157	31	378	332	635	51	11443
Apprch %	2.6	89	7.6	0.8	21.3	47	28	3.7	12.8	83.4	3.2	0.6	27.1	23.8	45.5	3.7	
Total %	1	33.7	2.9	0.3	1.4	3.1	1.9	0.2	5.6	36.1	1.4	0.3	3.3	2.9	5.5	0.4	



MINNESOTA DEPT OF TRANSPORTATION

TRAFFIC DATA COLLECTION - METRO

TH-952 / ROBERT ST. at ANNAPOLIS ST.

REF.PT.: 129.507

JAMAR# 631 RE

TURN MOVEMENT COUNT

File Name : TH-952 AT ANNAPOLIS ST

Site Code : 00000000

Start Date : 2/22/2006

Page No : 3

Start Time	TH-952 / ROBERT ST. Southbound					ANNAPOLIS ST. Westbound					TH-952 / ROBERT ST. Northbound					ANNAPOLIS ST. Eastbound					Int. Total
	Left	Thru	Right	Peds	App. Total	Left	Thru	Right	Peds	App. Total	Left	Thru	Right	Peds	App. Total	Left	Thru	Right	Peds	App. Total	
Peak Hour Analysis From 06:00 to 08:45 - Peak 1 of 1																					
Peak Hour for Entire Intersection Begins at 07:00																					
07:00	2	44	5	0	51	2	13	13	0	28	12	124	3	1	140	15	4	13	0	32	251
07:15	1	56	9	0	66	5	10	11	2	28	10	130	2	0	142	21	11	15	1	48	284
07:30	3	51	4	0	58	2	17	12	1	32	16	117	4	0	137	18	9	14	2	43	270
07:45	1	60	5	0	66	4	11	19	0	34	12	147	1	0	160	10	13	20	1	44	304
Total Volume	7	211	23	0	241	13	51	55	3	122	50	518	10	1	579	64	37	62	4	167	1109
% App. Total	2.9	87.6	9.5	0		10.7	41.8	45.1	2.5		8.6	89.5	1.7	0.2		38.3	22.2	37.1	2.4		
PHF	.583	.879	.639	.000	.913	.650	.750	.724	.375	.897	.781	.881	.625	.250	.905	.762	.712	.775	.500	.870	.912

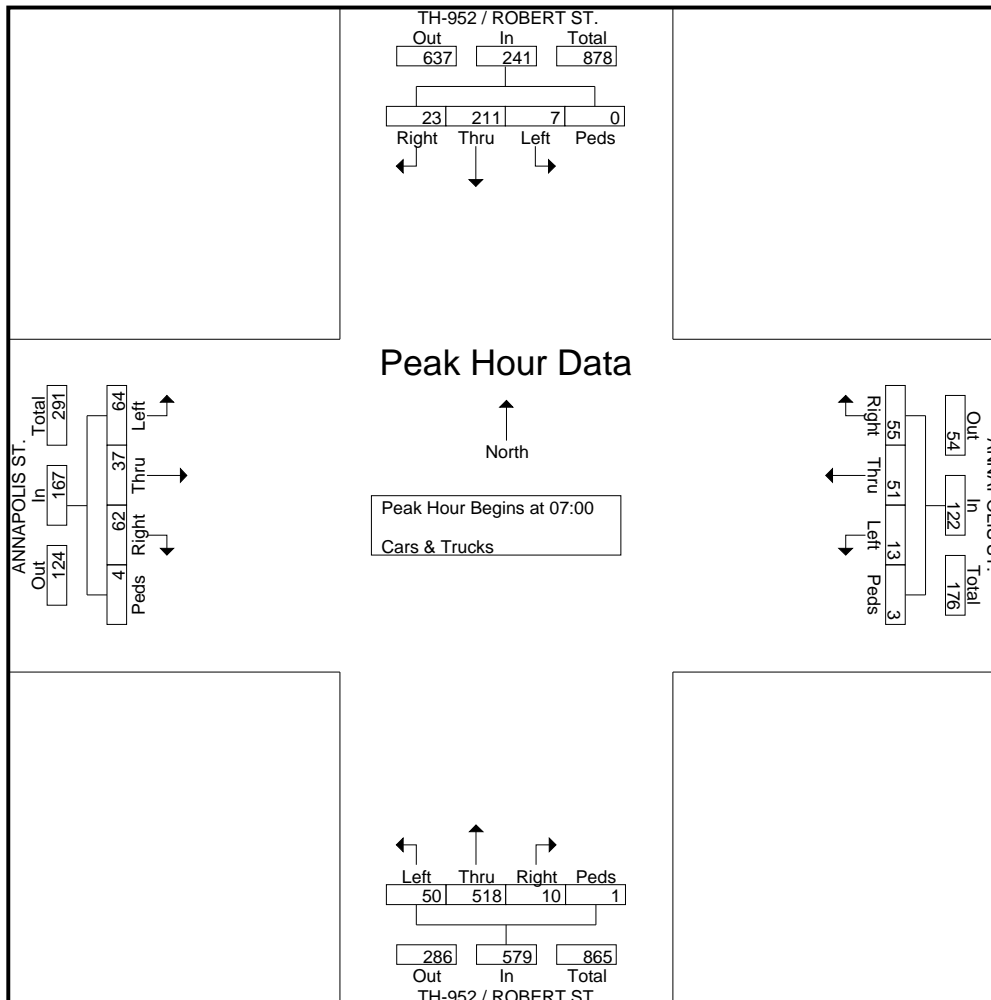



MINNESOTA DEPT OF TRANSPORTATION

TRAFFIC DATA COLLECTION - METRO

TH-952 / ROBERT ST. at ANNAPOLIS ST.

File Name : TH-952 AT ANNAPOLIS ST

REF.PT.: 129.507

Site Code : 00000000

JAMAR# 631 RE

Start Date : 2/22/2006

TURN MOVEMENT COUNT

Page No : 4

Start Time	TH-952 / ROBERT ST. Southbound					ANNAPOLIS ST. Westbound					TH-952 / ROBERT ST. Northbound					ANNAPOLIS ST. Eastbound					Int. Total
	Left	Thru	Right	Peds	App. Total	Left	Thru	Right	Peds	App. Total	Left	Thru	Right	Peds	App. Total	Left	Thru	Right	Peds	App. Total	
Peak Hour Analysis From 15:00 to 17:45 - Peak 1 of 1																					
Peak Hour for Entire Intersection Begins at 16:30																					
16:30	6	125	11	0	142	12	21	9	1	43	24	140	5	1	170	8	13	24	2	47	402
16:45	9	190	18	2	219	2	13	2	4	21	26	137	4	2	169	11	13	17	4	45	454
17:00	5	179	18	0	202	6	11	8	1	26	29	121	6	0	156	14	14	38	3	69	453
17:15	8	187	10	1	206	5	13	5	2	25	34	123	8	0	165	9	17	23	3	52	448
Total Volume	28	681	57	3	769	25	58	24	8	115	113	521	23	3	660	42	57	102	12	213	1757
% App. Total	3.6	88.6	7.4	0.4		21.7	50.4	20.9	7		17.1	78.9	3.5	0.5		19.7	26.8	47.9	5.6		
PHF	.778	.896	.792	.375	.878	.521	.690	.667	.500	.669	.831	.930	.719	.375	.971	.750	.838	.671	.750	.772	.968

