



# MINNESOTA DEPT. OF TRANSPORTATION

## TRAFFIC DATA COLLECTION - METRO

TH-952 / ROBERT ST. AT BUTLER AVE.  
 REF.PT.: 129.007  
 JAMAR# 631 RE  
 TURN MOVEMENT COUNT

File Name : th-952 robert st at butler ave 2006  
 Site Code : 00000000  
 Start Date : 5/3/2006  
 Page No : 1

**Groups Printed- CARS & TRUCKS**

Start Time	ROBERT ST./TH-952 Southbound				BUTLER AVE. Westbound				ROBERT ST./TH-952 Northbound				BUTLER AVE. Eastbound				Int. Total
	Left	Thru	Right	Peds	Left	Thru	Right	Peds	Left	Thru	Right	Peds	Left	Thru	Right	Peds	
06:00	5	33	1	0	7	14	5	0	3	40	15	0	1	11	1	0	136
06:15	8	28	2	0	14	17	8	0	4	58	16	0	2	21	7	0	185
06:30	3	39	5	0	14	24	13	0	17	76	7	0	12	29	7	0	246
06:45	10	55	3	0	26	20	8	0	10	95	19	0	13	16	11	0	286
Total	26	155	11	0	61	75	34	0	34	269	57	0	28	77	26	0	853
07:00	10	63	1	0	12	33	13	0	8	109	12	0	5	27	8	0	301
07:15	19	48	8	0	16	34	8	0	13	105	16	0	11	31	13	0	322
07:30	13	59	6	0	18	48	12	0	19	133	22	0	15	33	18	0	396
07:45	5	66	11	0	12	42	11	0	11	141	8	0	13	37	23	0	380
Total	47	236	26	0	58	157	44	0	51	488	58	0	44	128	62	0	1399
08:00	7	65	5	0	19	42	9	0	10	106	19	0	15	20	24	0	341
08:15	10	75	7	0	16	61	9	0	13	102	38	0	4	27	23	0	385
08:30	6	71	5	0	11	30	9	0	12	100	15	0	8	40	21	0	328
08:45	8	93	7	0	8	37	6	0	8	102	18	0	8	27	10	0	332
Total	31	304	24	0	54	170	33	0	43	410	90	0	35	114	78	0	1386
11:00	10	129	11	0	21	25	11	0	27	106	27	0	9	25	16	0	417
11:15	14	126	6	0	18	37	10	0	21	101	18	0	9	21	17	0	398
11:30	12	138	5	0	32	27	8	0	13	115	17	0	4	20	17	0	408
11:45	6	136	6	0	34	44	7	0	16	133	22	0	8	27	17	0	456
Total	42	529	28	0	105	133	36	0	77	455	84	0	30	93	67	0	1679
12:00	15	195	10	0	27	29	15	0	22	148	21	0	10	28	27	0	547
12:15	14	183	11	0	32	27	15	0	23	168	38	0	7	29	21	0	568
12:30	4	142	8	0	31	35	12	0	17	196	34	0	5	28	20	0	532
12:45	7	135	10	0	27	32	14	0	20	163	26	0	14	29	21	0	498
Total	40	655	39	0	117	123	56	0	82	675	119	0	36	114	89	0	2145
15:00	15	151	11	0	22	40	18	0	19	126	32	0	7	55	20	0	516
15:15	16	142	16	0	21	49	12	0	1	156	29	0	16	30	1	0	489
15:30	15	175	10	0	21	62	18	0	17	154	28	0	9	43	41	0	593
15:45	16	159	19	0	29	48	8	0	28	184	47	0	13	42	25	0	618
Total	62	627	56	0	93	199	56	0	65	620	136	0	45	170	87	0	2216
16:00	14	164	10	0	28	58	15	0	31	161	45	0	11	45	28	0	610
16:15	17	170	15	0	18	47	8	0	34	177	38	0	19	34	29	0	606
16:30	26	160	10	0	26	62	16	0	24	160	31	0	16	51	34	0	616
16:45	24	210	12	0	18	55	22	0	28	181	32	0	14	43	42	0	681
Total	81	704	47	0	90	222	61	0	117	679	146	0	60	173	133	0	2513
17:00	21	149	16	0	15	53	5	0	33	180	30	0	12	44	41	0	599
17:15	17	217	19	0	19	71	7	0	38	178	28	0	10	39	40	0	683
17:30	21	169	19	0	29	53	22	0	32	182	38	0	17	41	33	0	656
17:45	14	174	14	0	17	45	19	0	22	178	38	0	10	41	37	0	609
Total	73	709	68	0	80	222	53	0	125	718	134	0	49	165	151	0	2547



# MINNESOTA DEPT. OF TRANSPORTATION

## TRAFFIC DATA COLLECTION - METRO

TH-952 / ROBERT ST. AT BUTLER AVE.  
 REF.PT.: 129.007  
 JAMAR# 631 RE  
 TURN MOVEMENT COUNT

File Name : th-952 robert st at butler ave 2006  
 Site Code : 00000000  
 Start Date : 5/3/2006  
 Page No : 2

**Groups Printed- CARS & TRUCKS**

	ROBERT ST./TH-952 Southbound				BUTLER AVE. Westbound				ROBERT ST./TH-952 Northbound				BUTLER AVE. Eastbound				Int. Total
	Left	Thru	Right	Peds	Left	Thru	Right	Peds	Left	Thru	Right	Peds	Left	Thru	Right	Peds	
Grand Total	402	3919	299	0	658	1301	373	0	594	4314	824	0	327	1034	693	0	14738
Apprch %	8.7	84.8	6.5	0	28.2	55.8	16	0	10.4	75.3	14.4	0	15.9	50.3	33.7	0	
Total %	2.7	26.6	2	0	4.5	8.8	2.5	0	4	29.3	5.6	0	2.2	7	4.7	0	



# MINNESOTA DEPT. OF TRANSPORTATION

## TRAFFIC DATA COLLECTION - METRO

TH-952 / ROBERT ST. AT BUTLER AVE.  
 REF.PT.: 129.007  
 JAMAR# 631 RE  
 TURN MOVEMENT COUNT

File Name : th-952 robert st at butler ave 2006  
 Site Code : 00000000  
 Start Date : 5/3/2006  
 Page No : 3

Start Time	ROBERT ST./TH-952 Southbound					BUTLER AVE. Westbound					ROBERT ST./TH-952 Northbound					BUTLER AVE. Eastbound					Int. Total
	Left	Thru	Right	Peds	App. Total	Left	Thru	Right	Peds	App. Total	Left	Thru	Right	Peds	App. Total	Left	Thru	Right	Peds	App. Total	
Peak Hour Analysis From 06:00 to 08:45 - Peak 1 of 1																					
Peak Hour for Entire Intersection Begins at 07:30																					
07:30	13	59	6	0	78	18	48	12	0	78	19	133	22	0	174	15	33	18	0	66	396
07:45	5	66	11	0	82	12	42	11	0	65	11	141	8	0	160	13	37	23	0	73	380
08:00	7	65	5	0	77	19	42	9	0	70	10	106	19	0	135	15	20	24	0	59	341
08:15	10	75	7	0	92	16	61	9	0	86	13	102	38	0	153	4	27	23	0	54	385
Total Volume	35	265	29	0	329	65	193	41	0	299	53	482	87	0	622	47	117	88	0	252	1502
% App. Total	10.6	80.5	8.8	0		21.7	64.5	13.7	0		8.5	77.5	14	0		18.7	46.4	34.9	0		
PHF	.673	.883	.659	.000	.894	.855	.791	.854	.000	.869	.697	.855	.572	.000	.894	.783	.791	.917	.000	.863	.948

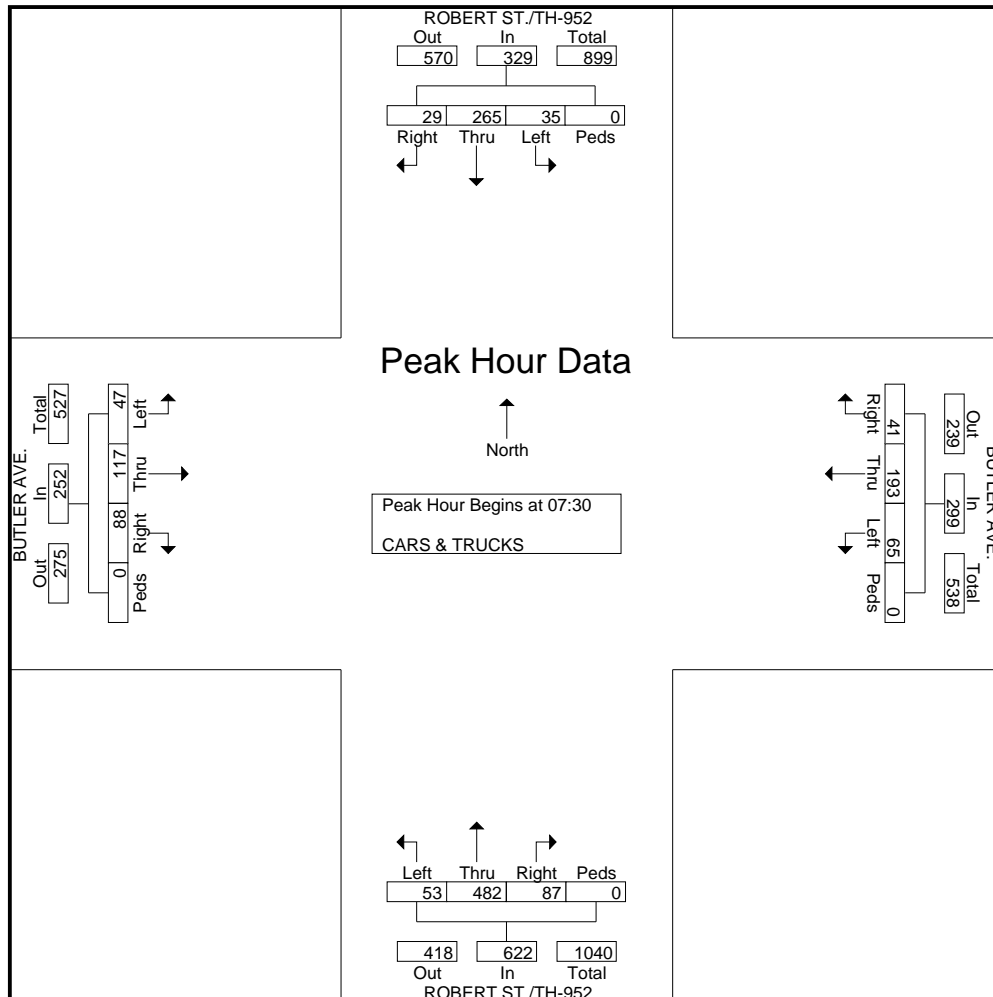



# MINNESOTA DEPT. OF TRANSPORTATION

## TRAFFIC DATA COLLECTION - METRO

TH-952 / ROBERT ST. AT BUTLER AVE.  
 REF.PT.: 129.007  
 JAMAR# 631 RE  
 TURN MOVEMENT COUNT

File Name : th-952 robert st at butler ave 2006  
 Site Code : 00000000  
 Start Date : 5/3/2006  
 Page No : 4

Start Time	ROBERT ST./TH-952 Southbound					BUTLER AVE. Westbound					ROBERT ST./TH-952 Northbound					BUTLER AVE. Eastbound					Int. Total
	Left	Thru	Right	Peds	App. Total	Left	Thru	Right	Peds	App. Total	Left	Thru	Right	Peds	App. Total	Left	Thru	Right	Peds	App. Total	
Peak Hour Analysis from 15:00 to 17:45 - Peak 1 of 1																					
Peak Hour for Entire Intersection Begins at 16:45																					
16:45	24	210	12	0	246	18	55	22	0	95	28	181	32	0	241	14	43	42	0	99	681
17:00	21	149	16	0	186	15	53	5	0	73	33	180	30	0	243	12	44	41	0	97	599
17:15	17	217	19	0	253	19	71	7	0	97	38	178	28	0	244	10	39	40	0	89	683
17:30	21	169	19	0	209	29	53	22	0	104	32	182	38	0	252	17	41	33	0	91	656
Total Volume	83	745	66	0	894	81	232	56	0	369	131	721	128	0	980	53	167	156	0	376	2619
% App. Total	9.3	83.3	7.4	0		22	62.9	15.2	0		13.4	73.6	13.1	0		14.1	44.4	41.5	0		
PHF	.865	.858	.868	.000	.883	.698	.817	.636	.000	.887	.862	.990	.842	.000	.972	.779	.949	.929	.000	.949	.959

