



MINNESOTA DEPT OF TRANSPORTATION

TRAFFIC COLLECTION - METRO

Location: TH 952 AT THOMPSON AVE
 REF.PT: 128+00.173
 JAMAR#632\DR
 TURN MOVEMENT COUNT

File Name : TH-952 AT THOMPSON AVE 2006
 Site Code : 00000000
 Start Date : 6/21/2006
 Page No : 1

Groups Printed- Cars & Trucks

Start Time	TH 952 Southbound				THOMPSON AVE Westbound				TH 952 Northbound				THOMPSON AVE Eastbound				Int. Total
	Right	Thru	Left	Peds	Right	Thru	Left	Peds	Right	Thru	Left	Peds	Right	Thru	Left	Peds	
06:00	4	37	11	0	16	6	4	0	2	37	3	0	0	12	9	0	141
06:15	6	35	5	0	6	8	7	0	10	48	5	0	3	13	4	0	150
06:30	4	49	13	0	17	12	8	0	10	62	2	0	3	21	11	0	212
06:45	3	59	9	0	11	12	10	0	18	65	3	0	3	10	7	0	210
Total	17	180	38	0	50	38	29	0	40	212	13	0	9	56	31	0	713
07:00	9	62	17	0	15	16	13	0	14	82	9	0	5	13	10	0	265
07:15	10	79	16	0	37	19	12	0	15	86	3	0	7	18	16	0	318
07:30	11	97	13	0	17	17	21	0	32	119	3	0	7	19	16	0	372
07:45	11	112	23	0	24	26	22	0	20	109	5	0	13	30	12	0	407
Total	41	350	69	0	93	78	68	0	81	396	20	0	32	80	54	0	1362
08:00	10	98	16	0	26	27	15	0	27	100	8	0	10	32	7	0	376
08:15	12	110	18	0	21	34	35	0	30	104	6	0	13	24	14	0	421
08:30	13	115	13	0	18	30	19	0	10	114	10	0	8	15	10	0	375
08:45	22	110	22	0	20	39	13	0	22	125	11	0	10	28	11	0	433
Total	57	433	69	0	85	130	82	0	89	443	35	0	41	99	42	0	1605
11:00	12	189	20	0	27	33	29	0	28	175	13	0	22	24	19	0	591
11:15	23	210	23	0	11	24	23	0	24	175	18	0	17	23	19	0	590
11:30	21	226	35	0	32	31	28	0	35	173	21	0	18	29	27	0	676
11:45	29	241	24	0	26	29	25	0	31	197	16	0	20	16	25	0	679
Total	85	866	102	0	96	117	105	0	118	720	68	0	77	92	90	0	2536
12:00	38	231	19	0	25	35	31	0	30	200	14	0	18	33	14	0	688
12:15	43	297	32	0	33	27	35	0	28	219	32	0	26	25	19	0	816
12:30	32	273	20	0	27	20	27	0	39	205	24	0	19	27	31	0	744
12:45	35	266	26	0	27	33	30	0	50	231	27	0	25	27	24	0	801
Total	148	1067	97	0	112	115	123	0	147	855	97	0	88	112	88	0	3049
15:00	19	189	22	0	37	34	24	0	34	193	22	1	26	23	22	0	646
15:15	25	191	25	0	23	30	32	0	33	172	12	0	17	35	19	0	614
15:30	30	211	22	0	20	37	24	0	30	216	27	0	17	28	24	0	686
15:45	22	186	34	0	21	52	38	2	31	209	21	0	19	28	22	0	685
Total	96	777	103	0	101	153	118	2	128	790	82	1	79	114	87	0	2631
16:00	17	219	20	0	13	52	31	0	35	220	22	0	24	49	19	0	721
16:15	25	210	27	0	27	48	24	1	41	219	12	0	23	45	33	0	735
16:30	23	247	32	0	18	49	23	0	29	200	20	0	20	39	23	0	723
16:45	26	267	35	0	30	34	22	0	42	232	21	0	14	37	23	0	783
Total	91	943	114	0	88	183	100	1	147	871	75	0	81	170	98	0	2962
17:00	20	257	29	0	31	48	26	0	38	233	16	0	22	51	26	0	797
17:15	23	264	36	0	33	31	29	0	44	220	21	0	19	41	21	0	782
17:30	24	207	23	0	35	54	28	0	40	228	13	0	17	31	21	0	721
17:45	23	219	20	0	41	24	20	0	34	225	20	0	26	26	31	0	709
Total	90	947	108	0	140	157	103	0	156	906	70	0	84	149	99	0	3009
Grand Total	625	5563	700	0	765	971	728	3	906	5193	460	1	491	872	589	0	17867
Apprch %	9.1	80.8	10.2	0	31	39.4	29.5	0.1	13.8	79.2	7	0	25.2	44.7	30.2	0	
Total %	3.5	31.1	3.9	0	4.3	5.4	4.1	0	5.1	29.1	2.6	0	2.7	4.9	3.3	0	



MINNESOTA DEPT OF TRANSPORTATION

TRAFFIC COLLECTION - METRO

File Name : TH-952 AT THOMPSON AVE 2006

Site Code : 00000000

Start Date : 6/21/2006

Page No : 2

Start Time	TH 952 Southbound					THOMPSON AVE Westbound					TH 952 Northbound					THOMPSON AVE Eastbound					Int. Total
	Right	Thru	Left	Peds	App. Total	Right	Thru	Left	Peds	App. Total	Right	Thru	Left	Peds	App. Total	Right	Thru	Left	Peds	App. Total	
Peak Hour Analysis From 06:00 to 09:45 - Peak 1 of 1																					
Peak Hour for Entire Intersection Begins at 08:00																					
08:00	10	98	16	0	124	26	27	15	0	68	27	100	8	0	135	10	32	7	0	49	376
08:15	12	110	18	0	140	21	34	35	0	90	30	104	6	0	140	13	24	14	0	51	421
08:30	13	115	13	0	141	18	30	19	0	67	10	114	10	0	134	8	15	10	0	33	375
08:45	22	110	23	0	154	20	39	13	0	72	22	125	11	0	158	10	28	11	0	49	433
Total Volume	57	433	69	0	559	85	130	82	0	297	89	443	35	0	567	41	99	42	0	182	1605
% App. Total	10.2	77.5	12.3	0		28.6	43.8	27.6	0		15.7	78.1	6.2	0		22.5	54.4	23.1	0		
PHF	.648	.941	.784	.000	.907	.817	.833	.586	.000	.825	.742	.886	.795	.000	.897	.788	.773	.750	.000	.892	.927

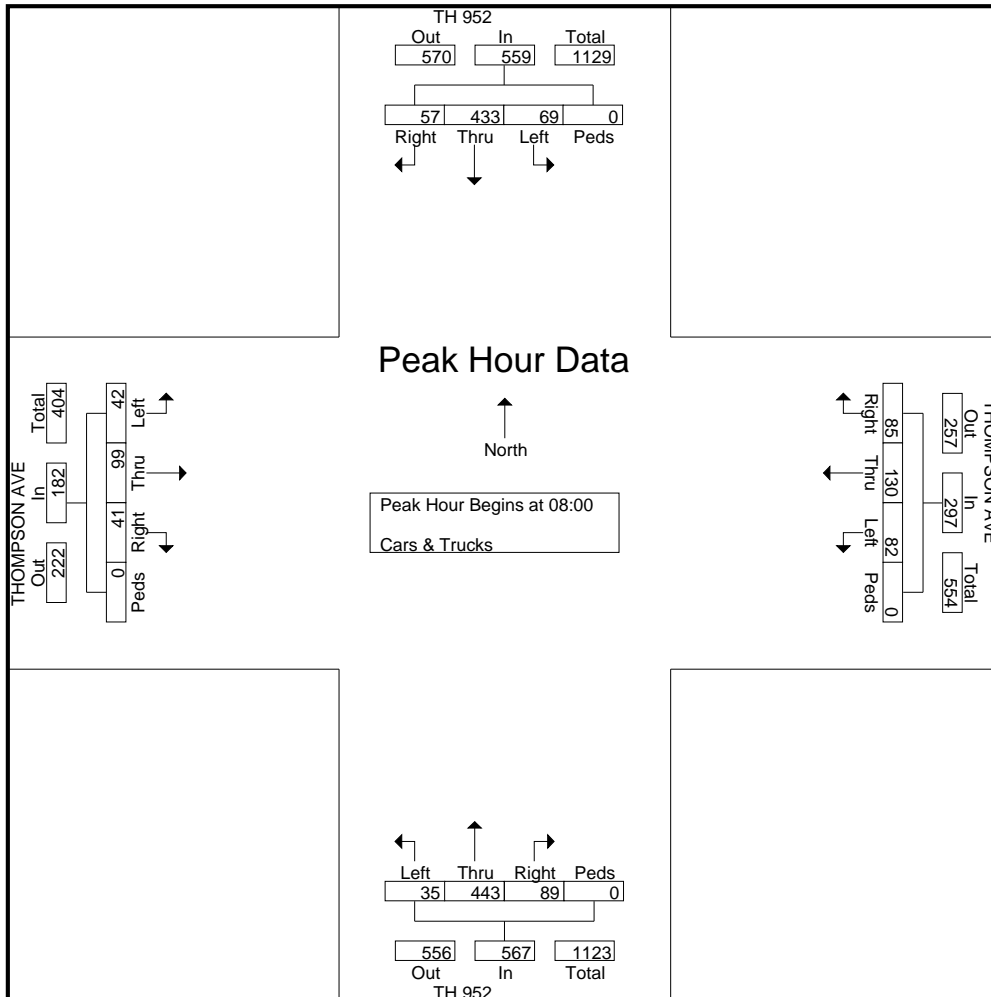



MINNESOTA DEPT OF TRANSPORTATION

TRAFFIC COLLECTION - METRO

File Name : TH-952 AT THOMPSON AVE 2006

Site Code : 00000000

Start Date : 6/21/2006

Page No : 3

Start Time	TH 952 Southbound					THOMPSON AVE Westbound					TH 952 Northbound					THOMPSON AVE Eastbound					Int. Total
	Right	Thru	Left	Peds	App. Total	Right	Thru	Left	Peds	App. Total	Right	Thru	Left	Peds	App. Total	Right	Thru	Left	Peds	App. Total	
Peak Hour Analysis From 10:00 to 13:45 - Peak 1 of 1																					
Peak Hour for Entire Intersection Begins at 12:00																					
12:00	38	231	19	0	288	25	35	31	0	91	30	200	14	0	244	18	33	14	0	65	688
12:15	43	297	32	0	372	33	27	35	0	95	28	219	32	0	279	26	25	19	0	70	816
12:30	32	273	20	0	325	27	20	27	0	74	39	205	24	0	268	19	27	31	0	77	744
12:45	35	266	26	0	327	27	33	30	0	90	50	231	27	0	308	25	27	24	0	76	801
Total Volume	148	1067	97	0	1312	112	115	123	0	350	147	855	97	0	1099	88	112	88	0	288	3049
% App. Total	11.3	81.3	7.4	0		32	32.9	35.1	0		13.4	77.8	8.8	0		30.6	38.9	30.6	0		
PHF	.860	.898	.758	.000	.882	.848	.821	.879	.000	.921	.735	.925	.758	.000	.892	.846	.848	.710	.000	.935	.934

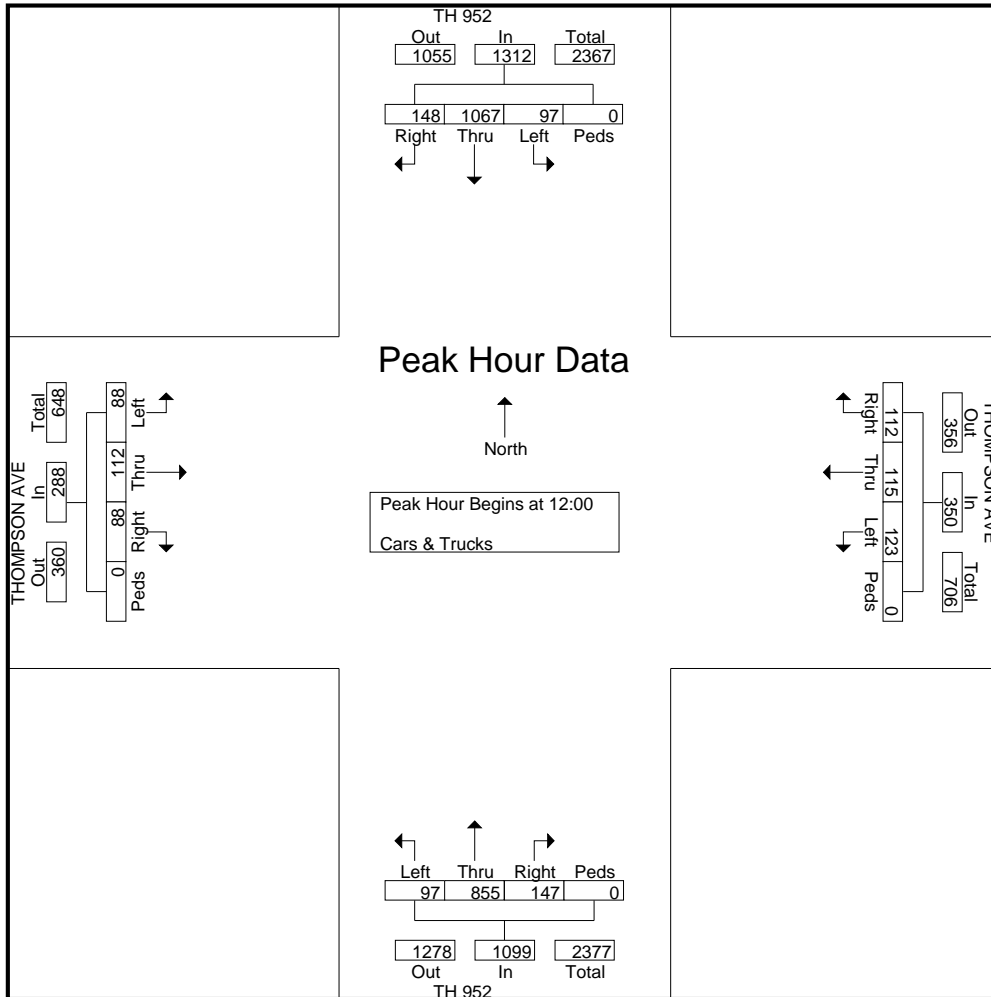



MINNESOTA DEPT OF TRANSPORTATION

TRAFFIC COLLECTION - METRO

File Name : TH-952 AT THOMPSON AVE 2006

Site Code : 00000000

Start Date : 6/21/2006

Page No : 4

Start Time	TH 952 Southbound					THOMPSON AVE Westbound					TH 952 Northbound					THOMPSON AVE Eastbound					Int. Total
	Right	Thru	Left	Peds	App. Total	Right	Thru	Left	Peds	App. Total	Right	Thru	Left	Peds	App. Total	Right	Thru	Left	Peds	App. Total	
Peak Hour Analysis From 14:00 to 17:45 - Peak 1 of 1																					
Peak Hour for Entire Intersection Begins at 16:30																					
16:30	23	247	32	0	302	18	49	23	0	90	29	200	20	0	249	20	39	23	0	82	723
16:45	26	267	35	0	328	30	34	22	0	86	42	232	21	0	295	14	37	23	0	74	783
17:00	20	257	29	0	306	31	48	26	0	105	38	233	16	0	287	22	51	26	0	99	797
17:15	23	264	36	0	323	33	31	29	0	93	44	220	21	0	285	19	41	21	0	81	782
Total Volume	92	1035	132	0	1259	112	162	100	0	374	153	885	78	0	1116	75	168	93	0	336	3085
% App. Total	7.3	82.2	10.5	0		29.9	43.3	26.7	0		13.7	79.3	7	0		22.3	50	27.7	0		
PHF	.885	.969	.917	.000	.960	.848	.827	.862	.000	.890	.869	.950	.929	.000	.946	.852	.824	.894	.000	.848	.968

