



# MINNESOTA DEPT OF TRANSPORTATION

## TRAFFIC COLLECTION - METRO

Location: TH-3 AT 54TH ST / S RAMP I-494

File Name : TH- 3 AT 54TH ST I-494 SR 2006

REF.PT: 043+OO.375

Site Code : 00000000

JAMAR#632\DR

Start Date : 4/12/2006

TURN MOVEMENT COUNT

Page No : 1

### Groups Printed- Cars & Trucks

Start Time	TH-3 / ROBERT TRAIL Southbound				54TH ST. Westbound				TH-3 / ROBERT TRAIL Northbound				RAMP FROM EB I-494 Eastbound				Int. Total
	Right	Thru	Left	Peds	Right	Thru	Left	Peds	Right	Thru	Left	Peds	Right	Thru	Left	Peds	
06:00	0	13	2	0	5	0	0	0	2	30	0	0	5	0	16	0	73
06:15	0	27	3	0	9	0	0	0	0	47	0	0	4	5	27	0	122
06:30	0	22	3	0	18	0	0	0	2	75	0	0	9	6	42	0	177
06:45	0	36	3	0	21	0	0	0	3	98	0	0	23	0	52	0	236
Total	0	98	11	0	53	0	0	0	7	250	0	0	41	11	137	0	608
07:00	0	29	5	0	14	0	1	0	0	111	0	0	14	2	41	0	217
07:15	0	36	8	0	31	0	1	0	5	124	0	0	47	5	62	0	319
07:30	0	28	9	0	22	0	1	0	2	125	0	0	32	0	58	0	277
07:45	0	51	4	0	22	0	1	0	3	136	0	0	23	4	75	0	319
Total	0	144	26	0	89	0	4	0	10	496	0	0	116	11	236	0	1132
08:00	0	51	1	0	22	0	0	0	2	115	0	0	29	3	62	0	285
08:15	0	35	8	0	38	0	1	0	3	89	0	0	15	3	68	0	260
08:30	0	43	13	0	23	0	2	0	1	73	0	0	15	1	58	0	229
08:45	0	43	10	0	17	0	0	0	3	65	0	0	21	6	82	0	247
Total	0	172	32	0	100	0	3	0	9	342	0	0	80	13	270	0	1021
15:00	0	82	14	0	34	0	4	0	4	76	0	0	14	9	82	0	319
15:15	0	86	18	0	25	0	0	0	1	82	0	0	33	12	105	0	362
15:30	0	95	21	0	27	0	3	0	4	82	0	0	36	7	93	0	368
15:45	0	85	23	0	33	0	1	0	5	68	0	0	36	8	120	0	379
Total	0	348	76	0	119	0	8	0	14	308	0	0	119	36	400	0	1428
16:00	0	122	22	0	29	0	0	0	1	71	0	0	31	11	86	0	373
16:15	0	93	17	0	33	0	2	0	7	89	0	0	49	10	97	0	397
16:30	0	110	23	0	35	0	2	0	4	97	0	0	38	6	95	0	410
16:45	0	135	16	0	30	0	0	0	4	89	0	0	41	14	136	0	465
Total	0	460	78	0	127	0	4	0	16	346	0	0	159	41	414	0	1645
17:00	0	114	18	0	44	0	3	0	0	80	0	0	60	11	105	0	435
17:15	0	88	17	0	23	0	1	0	1	99	0	0	38	16	129	0	412
17:30	0	130	19	0	29	0	4	0	4	83	0	0	32	4	114	0	419
17:45	0	97	25	0	39	0	1	0	6	65	0	0	41	19	94	0	387
Total	0	429	79	0	135	0	9	0	11	327	0	0	171	50	442	0	1653
Grand Total	0	1651	302	0	623	0	28	0	67	2069	0	0	686	162	1899	0	7487
Apprch %	0	84.5	15.5	0	95.7	0	4.3	0	3.1	96.9	0	0	25	5.9	69.1	0	
Total %	0	22.1	4	0	8.3	0	0.4	0	0.9	27.6	0	0	9.2	2.2	25.4	0	



# MINNESOTA DEPT OF TRANSPORTATION

TRAFFIC COLLECTION - METRO

Location: TH-3 AT 54TH ST / S RAMP I-494  
 REF.PT: 043+OO.375  
 JAMAR#632\DR  
 TURN MOVEMENT COUNT

File Name : TH- 3 AT 54TH ST I-494 SR 2006  
 Site Code : 00000000  
 Start Date : 4/12/2006  
 Page No : 2

Start Time	TH-3 / ROBERT TRAIL Southbound					54TH ST. Westbound					TH-3 / ROBERT TRAIL Northbound					RAMP FROM EB I-494 Eastbound					Int. Total
	Right	Thru	Left	Peds	App. Total	Right	Thru	Left	Peds	App. Total	Right	Thru	Left	Peds	App. Total	Right	Thru	Left	Peds	App. Total	
Peak Hour Analysis From 06:00 to 08:45 - Peak 1 of 1																					
Peak Hour for Entire Intersection Begins at 07:15																					
07:15	0	36	8	0	44	31	0	1	0	32	5	124	0	0	129	47	5	62	0	114	319
07:30	0	28	9	0	37	22	0	1	0	23	2	125	0	0	127	32	0	58	0	90	277
07:45	0	51	4	0	55	22	0	1	0	23	3	136	0	0	139	23	4	75	0	102	319
08:00	0	51	1	0	52	22	0	0	0	22	2	115	0	0	117	29	3	62	0	94	285
Total Volume	0	166	22	0	188	97	0	3	0	100	12	500	0	0	512	131	12	257	0	400	1200
% App. Total	0	88.3	11.7	0		97	0	3	0		2.3	97.7	0	0		32.8	3	64.2	0		
PHF	.000	.814	.611	.000	.855	.782	.000	.750	.000	.781	.600	.919	.000	.000	.921	.697	.600	.857	.000	.877	.940

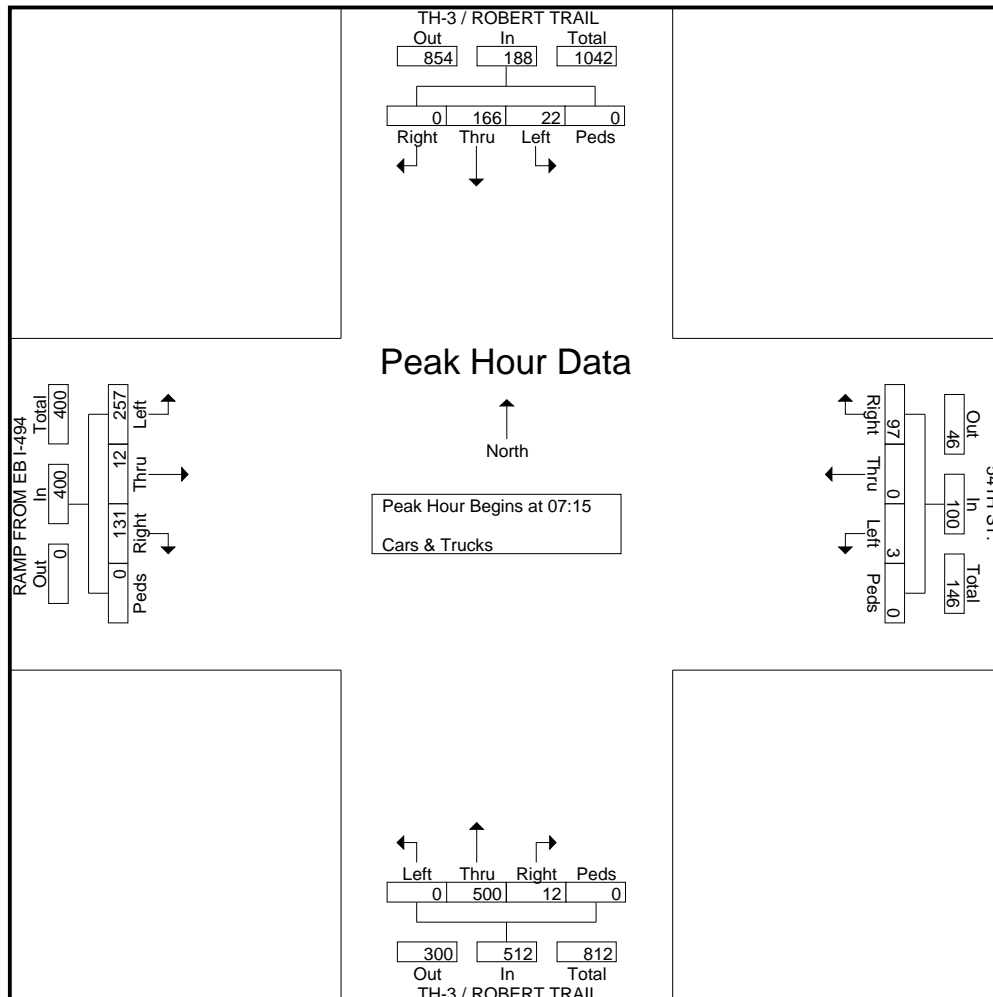



# MINNESOTA DEPT OF TRANSPORTATION

TRAFFIC COLLECTION - METRO

Location: TH-3 AT 54TH ST / S RAMP I-494  
 REF.PT: 043+OO.375  
 JAMAR#632\DR  
 TURN MOVEMENT COUNT

File Name : TH- 3 AT 54TH ST I-494 SR 2006  
 Site Code : 00000000  
 Start Date : 4/12/2006  
 Page No : 3

Start Time	TH-3 / ROBERT TRAIL Southbound					54TH ST. Westbound					TH-3 / ROBERT TRAIL Northbound					RAMP FROM EB I-494 Eastbound					Int. Total
	Right	Thru	Left	Peds	App. Total	Right	Thru	Left	Peds	App. Total	Right	Thru	Left	Peds	App. Total	Right	Thru	Left	Peds	App. Total	
Peak Hour Analysis From 15:00 to 17:45 - Peak 1 of 1																					
Peak Hour for Entire Intersection Begins at 16:45																					
16:45	0	135	16	0	151	30	0	0	0	30	4	89	0	0	93	41	14	136	0	191	465
17:00	0	114	18	0	132	44	0	3	0	47	0	80	0	0	80	60	11	105	0	176	435
17:15	0	88	17	0	105	23	0	1	0	24	1	99	0	0	100	38	16	129	0	183	412
17:30	0	130	19	0	149	29	0	4	0	33	4	83	0	0	87	32	4	114	0	150	419
Total Volume	0	467	70	0	537	126	0	8	0	134	9	351	0	0	360	171	45	484	0	700	1731
% App. Total	0	87	13	0		94	0	6	0		2.5	97.5	0	0		24.4	6.4	69.1	0		
PHF	.000	.865	.921	.000	.889	.716	.000	.500	.000	.713	.563	.886	.000	.000	.900	.713	.703	.890	.000	.916	.931

