

Albeck Gerken, Inc

Transportation Engineers

Traffic Data Collection

TH-3 at TH-50 , south Jct
Farmington, MN
Ref.Pt.: 025.357
TURN MOVEMENT COUNT

File Name : TH-3 at TH-50 south jct 2012
Site Code : 34
Start Date : 1/13/2012
Page No : 1

Groups Printed- Cars - Heavy Vehicles

Start Time	TH-3 / Chippendale Ave W Southbound				TH-50 / Ash St. Westbound				TH-3 / Chippendale Ave W Northbound				220th St. Eastbound				Int. Total
	Left	Thru	Right	Peds	Left	Thru	Right	Peds	Left	Thru	Right	Peds	Left	Thru	Right	Peds	
06:00	9	14	4	0	4	11	11	0	9	35	2	0	3	11	4	0	117
06:15	14	20	3	0	3	24	11	0	11	39	1	0	0	11	5	0	142
06:30	6	31	8	0	2	30	14	0	14	52	5	0	6	11	11	0	190
06:45	10	28	7	0	5	35	17	0	27	56	6	0	7	14	9	0	221
Total	39	93	22	0	14	100	53	0	61	182	14	0	16	47	29	0	670
07:00	10	29	3	0	8	25	17	0	11	50	3	0	4	18	12	0	190
07:15	12	32	15	0	5	33	18	1	9	56	4	0	9	27	15	0	236
07:30	14	42	6	0	5	24	22	0	18	68	6	0	12	16	16	0	249
07:45	12	40	4	0	4	25	18	0	12	56	5	0	8	18	18	0	220
Total	48	143	28	0	22	107	75	1	50	230	18	0	33	79	61	0	895
08:00	12	15	3	0	3	19	20	0	10	37	4	0	7	13	9	0	152
08:15	17	29	3	0	4	20	14	0	15	52	1	0	7	12	12	0	186
08:30	15	23	9	0	2	19	19	0	12	36	5	0	4	10	10	0	164
08:45	8	21	4	0	3	25	16	0	8	44	6	0	12	17	17	1	182
Total	52	88	19	0	12	83	69	0	45	169	16	0	30	52	48	1	684
09:00	9	22	6	0	9	8	11	0	7	26	3	0	5	12	14	0	132
09:15	13	27	5	0	6	14	14	0	13	39	8	0	3	24	11	0	177
09:30	19	29	3	1	2	16	12	0	9	35	4	0	4	8	10	0	152
09:45	16	31	8	0	5	8	14	0	4	28	6	0	3	7	8	0	138
Total	57	109	22	1	22	46	51	0	33	128	21	0	15	51	43	0	599
10:00	15	31	5	0	1	3	12	0	7	27	4	0	4	14	8	0	131
10:15	17	34	3	0	5	7	8	0	7	29	5	0	1	13	9	0	138
10:30	15	26	8	0	1	13	14	0	10	26	3	0	4	11	6	0	137
10:45	14	23	2	0	6	11	11	0	11	32	2	0	6	15	15	0	148
Total	61	114	18	0	13	34	45	0	35	114	14	0	15	53	38	0	554
11:00	12	22	7	0	3	14	20	2	5	30	6	0	3	9	10	0	143
11:15	16	23	3	0	4	8	23	0	6	46	3	0	6	14	9	0	161
11:30	13	41	3	0	9	15	11	0	12	47	8	0	5	17	13	0	194
11:45	23	39	4	0	4	19	19	0	10	40	9	0	8	22	8	0	205
Total	64	125	17	0	20	56	73	2	33	163	26	0	22	62	40	0	703
12:00	12	30	6	0	2	15	22	0	9	41	5	0	0	12	11	1	166
12:15	15	36	4	0	5	13	13	0	9	32	4	0	4	26	14	0	175
12:30	16	30	6	0	4	8	18	1	12	37	7	0	5	18	18	0	180
12:45	20	30	6	0	5	21	18	0	11	30	7	0	6	17	10	0	181
Total	63	126	22	0	16	57	71	1	41	140	23	0	15	73	53	1	702
13:00	18	20	6	0	9	12	21	0	9	35	5	0	5	10	19	0	169
13:15	16	40	6	0	5	13	13	0	12	34	2	0	3	23	18	0	185
13:30	14	28	4	0	3	21	29	0	14	37	0	1	3	24	16	0	194
13:45	24	37	5	0	6	19	18	0	8	39	4	0	3	10	10	0	183
Total	72	125	21	0	23	65	81	0	43	145	11	1	14	67	63	0	731
14:00	12	29	6	0	5	9	16	0	14	34	5	0	2	17	14	0	163
14:15	14	38	7	0	7	18	27	0	12	38	9	0	7	15	11	0	203
14:30	24	38	10	0	5	17	14	0	9	23	10	0	5	21	21	0	197
14:45	22	44	8	0	6	21	20	0	9	40	8	0	6	26	12	0	222
Total	72	149	31	0	23	65	77	0	44	135	32	0	20	79	58	0	785
15:00	21	51	6	0	6	22	17	0	12	36	8	0	4	19	15	1	218
15:15	20	47	8	0	7	21	13	0	13	42	5	0	4	35	15	1	231
15:30	21	47	9	1	9	22	14	0	12	36	5	0	19	45	38	0	278
15:45	19	58	8	0	9	20	21	0	15	46	6	0	8	49	20	0	279
Total	81	203	31	1	31	85	65	0	52	160	24	0	35	148	88	2	1006

Albeck Gerken, Inc

Transportation Engineers

Traffic Data Collection

TH-3 at TH-50 , south Jct
Farmington, MN
Ref.Pt.: 025.357
TURN MOVEMENT COUNT

File Name : TH-3 at TH-50 south jct 2012
Site Code : 34
Start Date : 1/13/2012
Page No : 2

Groups Printed- Cars - Heavy Vehicles

Start Time	TH-3 / Chippendale Ave W Southbound				TH-50 / Ash St. Westbound				TH-3 / Chippendale Ave W Northbound				220th St. Eastbound				Int. Total
	Left	Thru	Right	Peds	Left	Thru	Right	Peds	Left	Thru	Right	Peds	Left	Thru	Right	Peds	
16:00	29	77	5	0	4	25	35	0	9	51	5	0	8	41	35	2	326
16:15	18	56	6	1	8	16	23	0	15	48	4	0	7	41	28	0	271
16:30	31	61	8	0	7	27	24	0	7	49	4	0	9	35	25	0	287
16:45	18	63	12	0	5	21	28	0	12	53	3	0	5	33	20	0	273
Total	96	257	31	1	24	89	110	0	43	201	16	0	29	150	108	2	1157
17:00	28	46	12	0	9	31	21	1	8	59	6	1	7	38	24	1	292
17:15	23	57	8	0	8	28	19	0	15	55	3	0	6	37	12	0	271
17:30	29	46	9	0	5	26	23	0	14	43	3	0	6	38	15	0	257
17:45	22	48	23	0	5	28	20	0	12	44	10	0	9	20	22	0	263
Total	102	197	52	0	27	113	83	1	49	201	22	1	28	133	73	1	1083
18:00	18	36	8	0	4	19	16	0	12	44	5	0	7	23	20	0	212
18:15	20	38	10	0	3	14	19	0	14	55	2	0	7	16	20	0	218
18:30	22	34	4	0	5	23	27	1	9	40	1	0	5	10	14	0	195
18:45	15	23	6	0	6	22	16	0	10	33	5	0	7	24	12	0	179
Total	75	131	28	0	18	78	78	1	45	172	13	0	26	73	66	0	804
Grand Total	882	1860	342	3	265	978	931	6	574	2140	250	2	298	1067	768	7	10373
Apprch %	28.6	60.3	11.1	0.1	12.2	44.9	42.7	0.3	19.4	72.2	8.4	0.1	13.9	49.9	35.9	0.3	
Total %	8.5	17.9	3.3	0	2.6	9.4	9	0.1	5.5	20.6	2.4	0	2.9	10.3	7.4	0.1	
Cars	798	1736	326	3	238	915	824	6	515	1959	218	2	284	990	690	7	9511
% Cars	90.5	93.3	95.3	100	89.8	93.6	88.5	100	89.7	91.5	87.2	100	95.3	92.8	89.8	100	91.7
Heavy Vehicles	84	124	16	0	27	63	107	0	59	181	32	0	14	77	78	0	862
% Heavy Vehicles	9.5	6.7	4.7	0	10.2	6.4	11.5	0	10.3	8.5	12.8	0	4.7	7.2	10.2	0	8.3

Albeck Gerken, Inc

Transportation Engineers

Traffic Data Collection

TH-3 at TH-50 , south Jct
Farmington, MN
Ref.Pt.: 025.357
TURN MOVEMENT COUNT

File Name : TH-3 at TH-50 south jct 2012
Site Code : 34
Start Date : 1/13/2012
Page No : 3

Start Time	TH-3 / Chippendale Ave W Southbound					TH-50 / Ash St. Westbound					TH-3 / Chippendale Ave W Northbound					220th St. Eastbound					Int. Total
	Left	Thru	Right	Peds	App. Total	Left	Thru	Right	Peds	App. Total	Left	Thru	Right	Peds	App. Total	Left	Thru	Right	Peds	App. Total	
Peak Hour Analysis From 06:00 to 09:00 - Peak 1 of 1																					
Peak Hour for Entire Intersection Begins at 06:45																					
06:45	10	28	7	0	45	5	35	17	0	57	27	56	6	0	89	7	14	9	0	30	221
07:00	10	29	3	0	42	8	25	17	0	50	11	50	3	0	64	4	18	12	0	34	190
07:15	12	32	15	0	59	5	33	18	1	57	9	56	4	0	69	9	27	15	0	51	236
07:30	14	42	6	0	62	5	24	22	0	51	18	68	6	0	92	12	16	16	0	44	249
Total Volume	46	131	31	0	208	23	117	74	1	215	65	230	19	0	314	32	75	52	0	159	896
% App. Total	22.1	63	14.9	0		10.7	54.4	34.4	0.5		20.7	73.2	6.1	0		20.1	47.2	32.7	0		
PHF	.821	.780	.517	.000	.839	.719	.836	.841	.250	.943	.602	.846	.792	.000	.853	.667	.694	.813	.000	.779	.900

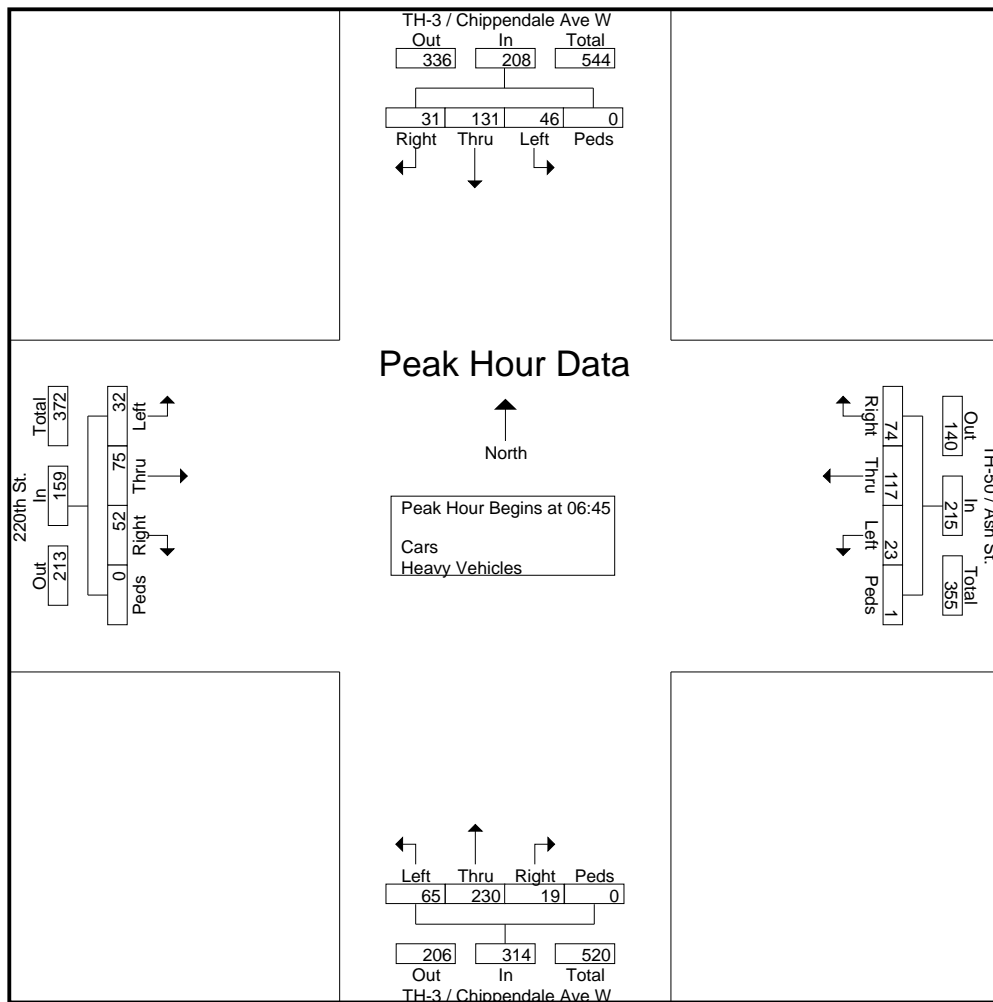

Albeck Gerken, Inc

Transportation Engineers

Traffic Data Collection

TH-3 at TH-50 , south Jct
Farmington, MN
Ref.Pt.: 025.357
TURN MOVEMENT COUNT

File Name : TH-3 at TH-50 south jct 2012
Site Code : 34
Start Date : 1/13/2012
Page No : 4

Start Time	TH-3 / Chippendale Ave W Southbound					TH-50 / Ash St. Westbound					TH-3 / Chippendale Ave W Northbound					220th St. Eastbound					Int. Total
	Left	Thru	Right	Peds	App. Total	Left	Thru	Right	Peds	App. Total	Left	Thru	Right	Peds	App. Total	Left	Thru	Right	Peds	App. Total	
Peak Hour Analysis From 15:00 to 18:45 - Peak 1 of 1																					
Peak Hour for Entire Intersection Begins at 15:45																					
15:45	19	58	8	0	85	9	20	21	0	50	15	46	6	0	67	8	49	20	0	77	279
16:00	29	77	5	0	111	4	25	35	0	64	9	51	5	0	65	8	41	35	2	86	326
16:15	18	56	6	1	81	8	16	23	0	47	15	48	4	0	67	7	41	28	0	76	271
16:30	31	61	8	0	100	7	27	24	0	58	7	49	4	0	60	9	35	25	0	69	287
Total Volume	97	252	27	1	377	28	88	103	0	219	46	194	19	0	259	32	166	108	2	308	1163
% App. Total	25.7	66.8	7.2	0.3		12.8	40.2	47	0		17.8	74.9	7.3	0		10.4	53.9	35.1	0.6		
PHF	.782	.818	.844	.250	.849	.778	.815	.736	.000	.855	.767	.951	.792	.000	.966	.889	.847	.771	.250	.895	.892

