



MINNESOTA DEPT OF TRANSPORTATION

TRAFFIC DATA COLLECTION - METRO

TH-280 at Larpenteur/Henn. Ave, E Ramps
 Ref.Pt.: 202.302
 JAMAR # 632 DR
 TURN MOVEMENT COUNT

File Name : TH-280 at Larpenteur Ave E ramp 2008
 Site Code : 00000000
 Start Date : 2/6/2008
 Page No : 1

Groups Printed- Cars & Trucks

Start Time	Ramp to TH-280 NB Southbound				Larpenteur Ave. Westbound				Ramp from TH-280 NB Northbound				Hennepin Ave. Eastbound				Int. Total
	Left	Thru	Right	Peds	Left	Thru	Right	Peds	Left	Thru	Right	Peds	Left	Thru	Right	Peds	
06:00	0	0	0	0	0	64	0	0	88	0	10	0	6	23	0	0	191
06:15	0	0	0	0	0	87	3	0	135	0	15	0	4	20	0	0	264
06:30	0	0	0	0	0	105	2	0	113	1	19	0	5	24	0	0	269
06:45	0	0	0	0	0	114	6	0	170	0	19	0	2	24	0	0	335
Total	0	0	0	0	0	370	11	0	506	1	63	0	17	91	0	0	1059
07:00	0	0	0	0	0	159	4	0	153	0	28	0	10	58	0	0	412
07:15	0	0	0	0	0	202	4	0	182	0	20	0	7	53	0	0	468
07:30	0	0	0	0	0	254	8	0	148	0	25	0	11	77	0	0	523
07:45	0	0	0	0	0	207	6	0	204	0	33	0	10	72	0	0	532
Total	0	0	0	0	0	822	22	0	687	0	106	0	38	260	0	0	1935
08:00	0	0	0	0	0	230	9	0	149	0	32	0	8	92	0	0	520
08:15	0	0	0	0	0	208	3	0	146	0	21	0	7	76	0	0	461
08:30	0	0	0	0	0	170	2	0	179	0	23	0	17	84	0	0	475
08:45	0	0	0	0	0	181	8	0	207	0	35	0	11	87	0	0	529
Total	0	0	0	0	0	789	22	0	681	0	111	0	43	339	0	0	1985
*** BREAK ***																	
14:45	0	0	0	0	0	68	16	0	128	0	38	0	25	77	0	0	352
Total	0	0	0	0	0	68	16	0	128	0	38	0	25	77	0	0	352
15:00	0	0	0	0	0	83	7	0	98	0	47	0	21	86	0	0	342
15:15	0	0	0	0	0	91	8	0	124	0	45	0	30	96	0	0	394
15:30	0	0	0	0	0	96	13	0	81	0	47	0	26	109	0	0	372
15:45	0	0	0	0	0	79	15	0	111	0	41	0	10	97	0	0	353
Total	0	0	0	0	0	349	43	0	414	0	180	0	87	388	0	0	1461
16:00	0	0	0	0	0	121	13	0	97	0	71	0	19	128	0	0	449
16:15	0	0	0	0	0	109	10	0	101	0	44	0	32	161	0	0	457
16:30	0	0	0	0	0	133	12	0	103	1	47	0	17	155	0	0	468
16:45	0	0	0	0	0	139	16	0	127	0	54	0	21	190	0	0	547
Total	0	0	0	0	0	502	51	0	428	1	216	0	89	634	0	0	1921
17:00	0	0	0	0	0	121	18	0	129	0	82	0	21	195	0	0	566
17:15	0	0	0	0	0	129	4	0	147	0	61	0	12	211	0	0	564
17:30	0	0	0	0	0	110	15	0	121	0	56	0	21	171	0	0	494
17:45	0	0	0	0	0	94	12	0	124	0	56	0	26	164	0	0	476
Total	0	0	0	0	0	454	49	0	521	0	255	0	80	741	0	0	2100
Grand Total	0	0	0	0	0	3354	214	0	3365	2	969	0	379	2530	0	0	10813
Aprrch %	0	0	0	0	0	94	6	0	77.6	0	22.3	0	13	87	0	0	
Total %	0	0	0	0	0	31	2	0	31.1	0	9	0	3.5	23.4	0	0	



MINNESOTA DEPT OF TRANSPORTATION

TRAFFIC DATA COLLECTION - METRO

TH-280 at Larpenteur/Henn. Ave, E Ramps
 Ref.Pt.: 202.302
 JAMAR # 632 DR
 TURN MOVEMENT COUNT

File Name : TH-280 at Larpenteur Ave E ramp 2008
 Site Code : 00000000
 Start Date : 2/6/2008
 Page No : 2

Start Time	Ramp to TH-280 NB Southbound					Larpenteur Ave. Westbound					Ramp from TH-280 NB Northbound					Hennepin Ave. Eastbound					Int. Total
	Left	Thru	Right	Peds	App. Total	Left	Thru	Right	Peds	App. Total	Left	Thru	Right	Peds	App. Total	Left	Thru	Right	Peds	App. Total	
Peak Hour Analysis From 06:00 to 08:45 - Peak 1 of 1																					
Peak Hour for Entire Intersection Begins at 07:15																					
07:15	0	0	0	0	0	0	202	4	0	206	182	0	20	0	202	7	53	0	0	60	468
07:30	0	0	0	0	0	0	254	8	0	262	148	0	25	0	173	11	77	0	0	88	523
07:45	0	0	0	0	0	0	207	6	0	213	204	0	33	0	237	10	72	0	0	82	532
08:00	0	0	0	0	0	0	230	9	0	239	149	0	32	0	181	8	92	0	0	100	520
Total Volume	0	0	0	0	0	0	893	27	0	920	683	0	110	0	793	36	294	0	0	330	2043
% App. Total	.000	.000	.000	.000	.000	.000	.879	.750	.000	.878	.837	.000	.833	.000	.836	.818	.799	.000	.000	.825	.960

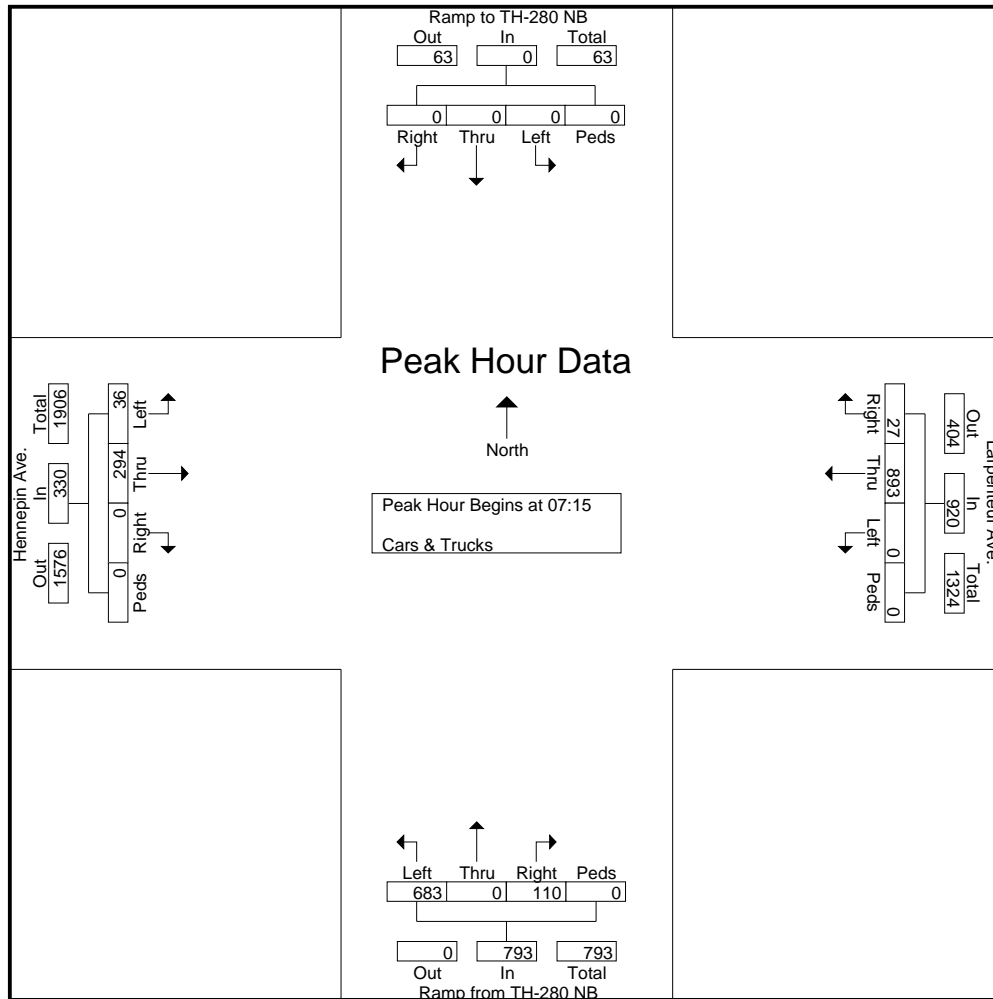



MINNESOTA DEPT OF TRANSPORTATION

TRAFFIC DATA COLLECTION - METRO

TH-280 at Larpenteur/Henn. Ave, E Ramps
 Ref.Pt.: 202.302
 JAMAR # 632 DR
 TURN MOVEMENT COUNT

File Name : TH-280 at Larpenteur Ave E ramp 2008
 Site Code : 00000000
 Start Date : 2/6/2008
 Page No : 3

Start Time	Ramp to TH-280 NB Southbound					Larpenteur Ave. Westbound					Ramp from TH-280 NB Northbound					Hennepin Ave. Eastbound					Int. Total
	Left	Thru	Right	Peds	App. Total	Left	Thru	Right	Peds	App. Total	Left	Thru	Right	Peds	App. Total	Left	Thru	Right	Peds	App. Total	
Peak Hour Analysis From 14:45 to 17:45 - Peak 1 of 1																					
Peak Hour for Entire Intersection Begins at 16:45																					
16:45	0	0	0	0	0	0	139	16	0	155	127	0	54	0	181	21	190	0	0	211	547
17:00	0	0	0	0	0	0	121	18	0	139	129	0	82	0	211	21	195	0	0	216	566
17:15	0	0	0	0	0	0	129	4	0	133	147	0	61	0	208	12	211	0	0	223	564
17:30	0	0	0	0	0	0	110	15	0	125	121	0	56	0	177	21	171	0	0	192	494
Total Volume	0	0	0	0	0	0	499	53	0	552	524	0	253	0	777	75	767	0	0	842	2171
% App. Total																					
PHF	.000	.000	.000	.000	.000	.000	.897	.736	.000	.890	.891	.000	.771	.000	.921	.893	.909	.000	.000	.944	.959

