



MINNESOTA DEPT OF TRANSPORTATION

TRAFFIC DATA COLLECTION - METRO

TH-25 at Main St E & Walnut St

Ref.Pt.: 000.730

JAMAR # T-2638 CAH

TURN MOVEMENT COUNT - Belle Plaine

File Name : TH-25 at Main St E - Walnut St 2011

Site Code : 00000000

Start Date : 3/17/2011

Page No : 2

Start Time	WALNUT ST N / TH-25 Southbound					MAIN ST E / TH-25 Westbound					WALNUT ST S Northbound					MAIN ST / Co.Rd.3 Eastbound					Int. Total
	Left	Thru	Right	Peds	App. Total	Left	Thru	Right	Peds	App. Total	Left	Thru	Right	Peds	App. Total	Left	Thru	Right	Peds	App. Total	
Peak Hour Analysis From 06:00 to 08:45 - Peak 1 of 1																					
Peak Hour for Entire Intersection Begins at 07:30																					
07:30	23	0	14	0	37	1	53	24	0	78	0	1	4	0	5	14	48	0	1	63	183
07:45	36	0	24	0	60	0	74	15	0	89	1	8	2	1	12	5	51	0	1	57	218
08:00	22	4	15	0	41	3	87	17	0	107	0	1	6	0	7	8	47	0	0	55	210
08:15	26	2	19	0	47	2	93	18	0	113	0	4	4	0	8	10	79	0	0	89	257
Total Volume	107	6	72	0	185	6	307	74	0	387	1	14	16	1	32	37	225	0	2	264	868
% App. Total	57.8	3.2	38.9	0		1.6	79.3	19.1	0		3.1	43.8	50	3.1		14	85.2	0	0.8		
PHF	.743	.375	.750	.000	.771	.500	.825	.771	.000	.856	.250	.438	.667	.250	.667	.661	.712	.000	.500	.742	.844

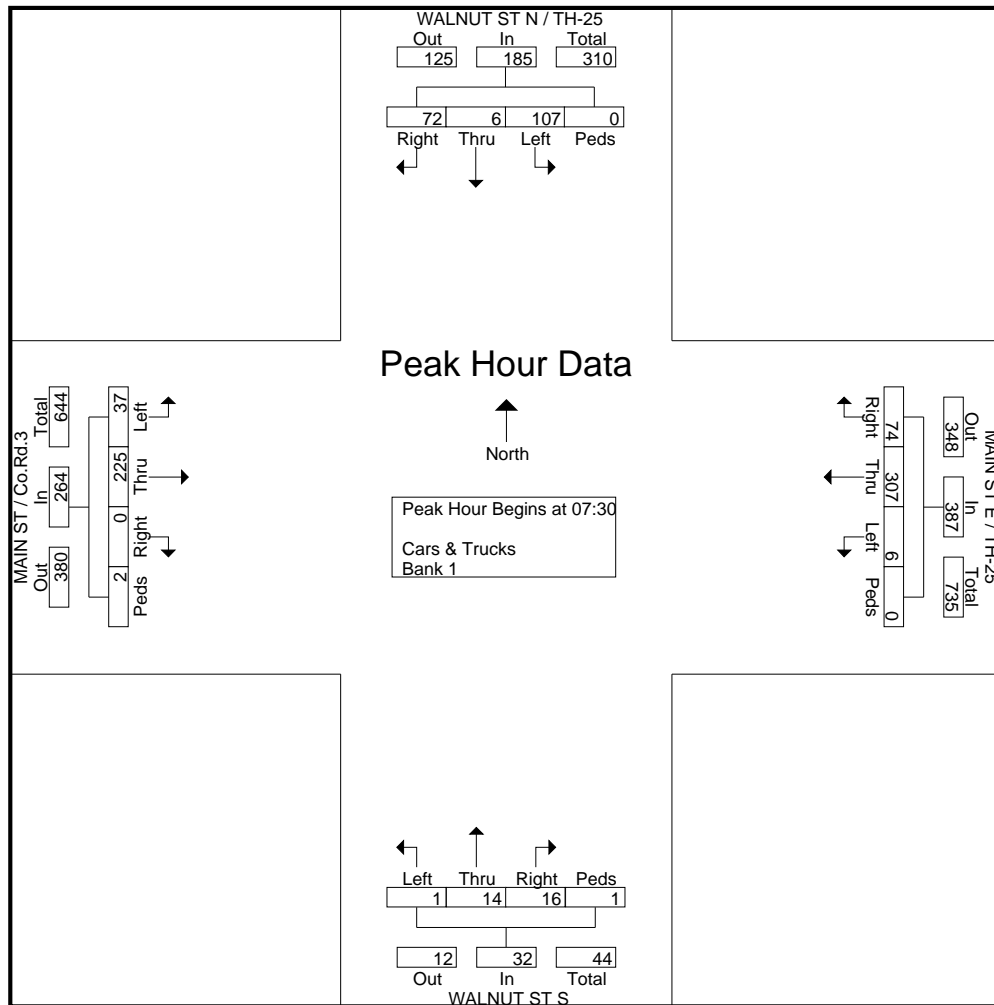



MINNESOTA DEPT OF TRANSPORTATION

TRAFFIC DATA COLLECTION - METRO

TH-25 at Main St E & Walnut St
 Ref.Pt.: 000.730
 JAMAR # T-2638 CAH
 TURN MOVEMENT COUNT - Belle Plaine

File Name : TH-25 at Main St E - Walnut St 2011
 Site Code : 00000000
 Start Date : 3/17/2011
 Page No : 3

Start Time	WALNUT ST N / TH-25 Southbound					MAIN ST E / TH-25 Westbound					WALNUT ST S Northbound					MAIN ST / Co.Rd.3 Eastbound					Int. Total
	Left	Thru	Right	Peds	App. Total	Left	Thru	Right	Peds	App. Total	Left	Thru	Right	Peds	App. Total	Left	Thru	Right	Peds	App. Total	
16:15	33	4	18	0	55	6	54	36	1	97	0	10	1	2	13	10	60	0	2	72	237
16:30	30	3	19	0	52	3	66	37	2	108	1	3	4	0	8	9	53	0	1	63	231
16:45	22	7	12	0	41	4	82	29	11	126	2	3	2	0	7	14	60	0	0	74	248
17:00	29	5	12	1	47	6	68	43	1	118	2	7	0	0	9	11	51	0	0	62	236
Total Volume	114	19	61	1	195	19	270	145	15	449	5	23	7	2	37	44	224	0	3	271	952
% App. Total	58.5	9.7	31.3	0.5		4.2	60.1	32.3	3.3		13.5	62.2	18.9	5.4		16.2	82.7	0	1.1		
PHF	.864	.679	.803	.250	.886	.792	.823	.843	.341	.891	.625	.575	.438	.250	.712	.786	.933	.000	.375	.916	.960

Peak Hour Analysis From 15:00 to 17:45 - Peak 1 of 1

Peak Hour for Entire Intersection Begins at 16:15

