

Alliant Engineering, Inc.

733 Marquette Ave #700, Minneapolis, MN 55402

Anderson Lakes Pkwy & Columbine Rd
 Ref Pt:
 data by: Alliant Inc
 TURN MOVEMENT COUNT

File Name : 4_EP_Anderson Lakes Parkway at Columbine Road
 Site Code :
 Start Date : 12/22/2020
 Page No : 1

Groups Printed- Cars - Trucks

Start Time	Columbine Rd Southbound					Anderson Lakes Pkwy Westbound					Columbine Rd Northbound					Anderson Lakes Pkwy Eastbound					Int. Total
	Right	Thru	Left	Peds	App. Total	Right	Thru	Left	Peds	App. Total	Right	Thru	Left	Peds	App. Total	Right	Thru	Left	Peds	App. Total	
06:00 AM	0	2	3	0	5	4	5	1	0	10	5	1	2	0	8	0	8	1	0	9	32
06:15 AM	3	0	1	0	4	5	7	1	0	13	7	0	0	0	7	0	9	4	0	13	37
06:30 AM	0	0	2	0	2	4	11	5	0	20	3	1	2	0	6	0	17	4	0	21	49
06:45 AM	0	0	2	0	2	5	11	9	0	25	5	3	3	0	11	2	13	3	0	18	56
Total	3	2	8	0	13	18	34	16	0	68	20	5	7	0	32	2	47	12	0	61	174
07:00 AM	0	0	0	0	0	4	14	3	0	21	8	3	3	0	14	3	15	1	0	19	54
07:15 AM	0	3	6	0	9	10	26	1	0	37	6	0	5	0	11	3	21	3	0	27	84
07:30 AM	4	3	2	0	9	5	21	3	0	29	11	1	2	0	14	3	22	9	0	34	86
07:45 AM	1	5	6	0	12	9	36	1	0	46	4	8	5	0	17	3	45	3	0	51	126
Total	5	11	14	0	30	28	97	8	0	133	29	12	15	0	56	12	103	16	0	131	350
08:00 AM	2	4	9	0	15	3	22	5	0	30	11	3	1	0	15	4	33	9	0	46	106
08:15 AM	2	3	8	0	13	11	32	8	0	51	6	3	4	0	13	4	30	7	0	41	118
08:30 AM	2	2	8	0	12	14	26	8	0	48	9	4	5	0	18	3	28	9	0	40	118
08:45 AM	11	0	12	0	23	18	29	6	0	53	9	2	6	0	17	2	45	12	0	59	152
Total	17	9	37	0	63	46	109	27	0	182	35	12	16	0	63	13	136	37	0	186	494
09:00 AM	6	4	15	1	26	13	34	2	0	49	6	9	4	1	20	1	22	14	1	38	133
09:15 AM	8	2	11	0	21	13	30	3	0	46	6	1	1	0	8	1	27	14	0	42	117
*** BREAK ***																					
Total	14	6	26	1	47	26	64	5	0	95	12	10	5	1	28	2	49	28	1	80	250
*** BREAK ***																					
10:30 AM	8	4	14	0	26	13	32	7	1	53	6	5	4	0	15	1	21	16	0	38	132
10:45 AM	8	1	19	0	28	15	33	3	0	51	7	5	5	0	17	2	30	20	0	52	148
Total	16	5	33	0	54	28	65	10	1	104	13	10	9	0	32	3	51	36	0	90	280
11:00 AM	10	3	12	0	25	16	28	3	0	47	9	2	0	0	11	1	38	20	0	59	142
11:15 AM	12	6	19	0	37	15	42	8	0	65	10	6	3	1	20	4	33	17	0	54	176
11:30 AM	16	8	29	0	53	21	42	7	0	70	11	4	2	0	17	1	42	26	0	69	209
11:45 AM	10	8	17	0	35	24	53	14	0	91	11	7	3	0	21	6	37	22	1	66	213
Total	48	25	77	0	150	76	165	32	0	273	41	19	8	1	69	12	150	85	1	248	740
12:00 PM	16	7	13	0	36	24	48	13	0	85	4	10	10	1	25	3	48	16	0	67	213
12:15 PM	18	3	18	0	39	25	65	10	0	100	15	8	3	0	26	4	44	26	0	74	239
12:30 PM	16	11	15	0	42	17	67	7	1	92	11	9	6	1	27	7	51	18	2	78	239
12:45 PM	15	6	17	0	38	21	63	11	0	95	2	8	5	0	15	0	43	22	0	65	213
Total	65	27	63	0	155	87	243	41	1	372	32	35	24	2	93	14	186	82	2	284	904
01:00 PM	18	8	9	0	35	30	38	10	0	78	12	10	2	0	24	3	43	25	0	71	208
01:15 PM	23	4	18	0	45	27	43	8	0	78	12	5	4	0	21	3	39	18	1	61	205
*** BREAK ***																					
Total	41	12	27	0	80	57	81	18	0	156	24	15	6	0	45	6	82	43	1	132	413
*** BREAK ***																					
02:30 PM	22	8	17	0	47	28	53	4	0	85	11	5	7	0	23	6	42	26	0	74	229
02:45 PM	24	5	32	0	61	31	63	10	0	104	6	12	4	0	22	4	47	18	0	69	256
Total	46	13	49	0	108	59	116	14	0	189	17	17	11	0	45	10	89	44	0	143	485
03:00 PM	23	8	16	0	47	23	45	9	2	79	6	7	3	0	16	3	49	18	2	72	214
03:15 PM	11	7	22	0	40	21	51	4	1	77	3	6	4	0	13	4	47	24	2	77	207
03:30 PM	19	6	30	0	55	22	52	6	0	80	7	9	1	0	17	0	58	6	0	64	216
03:45 PM	3	1	26	0	30	22	49	5	0	76	9	0	0	0	9	0	61	8	0	69	184
Total	56	22	94	0	172	88	197	24	3	312	25	22	8	0	55	7	215	56	4	282	821
04:00 PM	0	0	21	0	21	15	46	0	0	61	3	0	0	0	3	0	68	9	0	77	162

Alliant Engineering, Inc.

733 Marquette Ave #700, Minneapolis, MN 55402

Anderson Lakes Pkwy & Columbine Rd File Name : 4_EP_Anderson Lakes Parkway at Columbine Road
 Ref Pt: Site Code :
 data by: Alliant Inc Start Date : 12/22/2020
 TURN MOVEMENT COUNT Page No : 2

Groups Printed- Cars - Trucks

Start Time	Columbine Rd Southbound					Anderson Lakes Pkwy Westbound					Columbine Rd Northbound					Anderson Lakes Pkwy Eastbound					Int. Total
	Right	Thru	Left	Peds	App. Total	Right	Thru	Left	Peds	App. Total	Right	Thru	Left	Peds	App. Total	Right	Thru	Left	Peds	App. Total	
04:15 PM	1	5	19	0	25	18	72	3	0	93	2	3	0	0	5	0	61	25	0	86	209
04:30 PM	15	6	31	0	52	28	67	9	0	104	8	6	3	0	17	8	59	27	0	94	267
04:45 PM	20	3	22	0	45	29	61	13	0	103	6	8	3	0	17	6	62	35	0	103	268
Total	36	14	93	0	143	90	246	25	0	361	19	17	6	0	42	14	250	96	0	360	906
05:00 PM	14	3	22	0	39	30	49	9	0	88	17	7	3	0	27	6	52	31	0	89	243
05:15 PM	15	6	20	0	41	25	56	11	0	92	11	8	4	0	23	4	66	14	0	84	240
05:30 PM	11	6	19	0	36	15	57	10	0	82	7	1	2	0	10	7	54	11	0	72	200
05:45 PM	13	19	15	0	47	11	71	9	0	91	8	4	9	0	21	5	55	12	0	72	231
Total	53	34	76	0	163	81	233	39	0	353	43	20	18	0	81	22	227	68	0	317	914
Grand Total	400	180	597	1	1178	684	1650	259	5	2598	310	194	133	4	641	117	1585	603	9	2314	6731
Apprch %	34	15.3	50.7	0.1		26.3	63.5	10	0.2		48.4	30.3	20.7	0.6		5.1	68.5	26.1	0.4		
Total %	5.9	2.7	8.9	0	17.5	10.2	24.5	3.8	0.1	38.6	4.6	2.9	2	0.1	9.5	1.7	23.5	9	0.1	34.4	
Cars	394	176	589	1	1160	676	1611	256	5	2548	307	191	130	4	632	115	1554	601	9	2279	6619
% Cars	98.5	97.8	98.7	100	98.5	98.8	97.6	98.8	100	98.1	99	98.5	97.7	100	98.6	98.3	98	99.7	100	98.5	98.3
Trucks	6	4	8	0	18	8	39	3	0	50	3	3	3	0	9	2	31	2	0	35	112
% Trucks	1.5	2.2	1.3	0	1.5	1.2	2.4	1.2	0	1.9	1	1.5	2.3	0	1.4	1.7	2	0.3	0	1.5	1.7

Alliant Engineering, Inc.

733 Marquette Ave #700, Minneapolis, MN 55402

Anderson Lakes Pkwy & Columbine Rd
 Ref Pt:
 data by: Alliant Inc
 TURN MOVEMENT COUNT

File Name : 4_EP_Anderson Lakes Parkway at Columbine Road
 Site Code :
 Start Date : 12/22/2020
 Page No : 3

Start Time	Columbine Rd Southbound					Anderson Lakes Pkwy Westbound					Columbine Rd Northbound					Anderson Lakes Pkwy Eastbound					Int. Total
	Right	Thru	Left	Peds	App. Total	Right	Thru	Left	Peds	App. Total	Right	Thru	Left	Peds	App. Total	Right	Thru	Left	Peds	App. Total	
Peak Hour Analysis From 06:00 AM to 09:45 AM - Peak 1 of 1																					
Peak Hour for Entire Intersection Begins at 08:15 AM																					
08:15 AM	2	3	8	0	13	11	32	8	0	51	6	3	4	0	13	4	30	7	0	41	118
08:30 AM	2	2	8	0	12	14	26	8	0	48	9	4	5	0	18	3	28	9	0	40	118
08:45 AM	11	0	12	0	23	18	29	6	0	53	9	2	6	0	17	2	45	12	0	59	152
09:00 AM	6	4	15	1	26	13	34	2	0	49	6	9	4	1	20	1	22	14	1	38	133
Total Volume	21	9	43	1	74	56	121	24	0	201	30	18	19	1	68	10	125	42	1	178	521
% App. Total	28.4	12.2	58.1	1.4		27.9	60.2	11.9	0		44.1	26.5	27.9	1.5		5.6	70.2	23.6	0.6		
PHF	.477	.563	.717	.250	.712	.778	.890	.750	.000	.948	.833	.500	.792	.250	.850	.625	.694	.750	.250	.754	.857

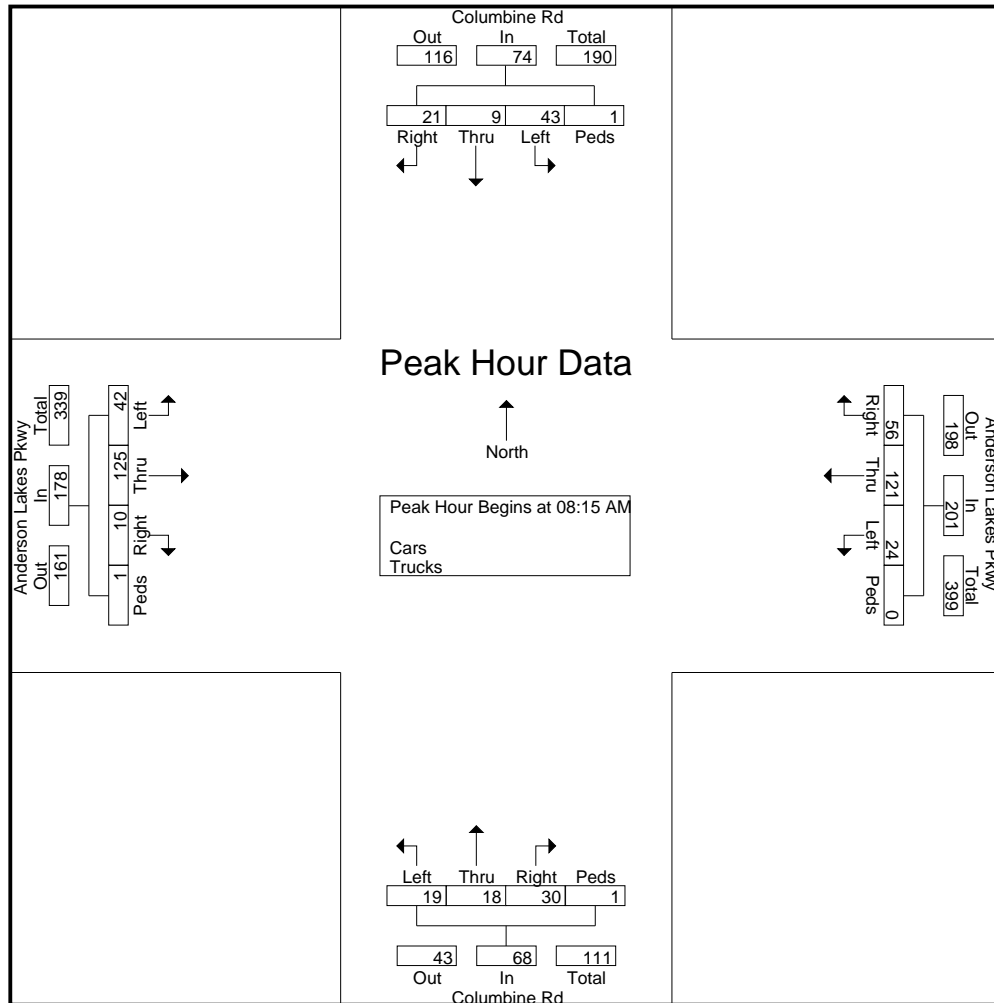

Alliant Engineering, Inc.

733 Marquette Ave #700, Minneapolis, MN 55402

Anderson Lakes Pkwy & Columbine Rd
 Ref Pt:
 data by: Alliant Inc
 TURN MOVEMENT COUNT

File Name : 4_EP_Anderson Lakes Parkway at Columbine Road
 Site Code :
 Start Date : 12/22/2020
 Page No : 4

Start Time	Columbine Rd Southbound					Anderson Lakes Pkwy Westbound					Columbine Rd Northbound					Anderson Lakes Pkwy Eastbound					Int. Total
	Right	Thru	Left	Peds	App. Total	Right	Thru	Left	Peds	App. Total	Right	Thru	Left	Peds	App. Total	Right	Thru	Left	Peds	App. Total	
Peak Hour Analysis From 10:00 AM to 01:45 PM - Peak 1 of 1																					
Peak Hour for Entire Intersection Begins at 11:45 AM																					
11:45 AM	10	8	17	0	35	24	53	14	0	91	11	7	3	0	21	6	37	22	1	66	213
12:00 PM	16	7	13	0	36	24	48	13	0	85	4	10	10	1	25	3	48	16	0	67	213
12:15 PM	18	3	18	0	39	25	65	10	0	100	15	8	3	0	26	4	44	26	0	74	239
12:30 PM	16	11	15	0	42	17	67	7	1	92	11	9	6	1	27	7	51	18	2	78	239
Total Volume	60	29	63	0	152	90	233	44	1	368	41	34	22	2	99	20	180	82	3	285	904
% App. Total	39.5	19.1	41.4	0		24.5	63.3	12	0.3		41.4	34.3	22.2	2		7	63.2	28.8	1.1		
PHF	.833	.659	.875	.000	.905	.900	.869	.786	.250	.920	.683	.850	.550	.500	.917	.714	.882	.788	.375	.913	.946

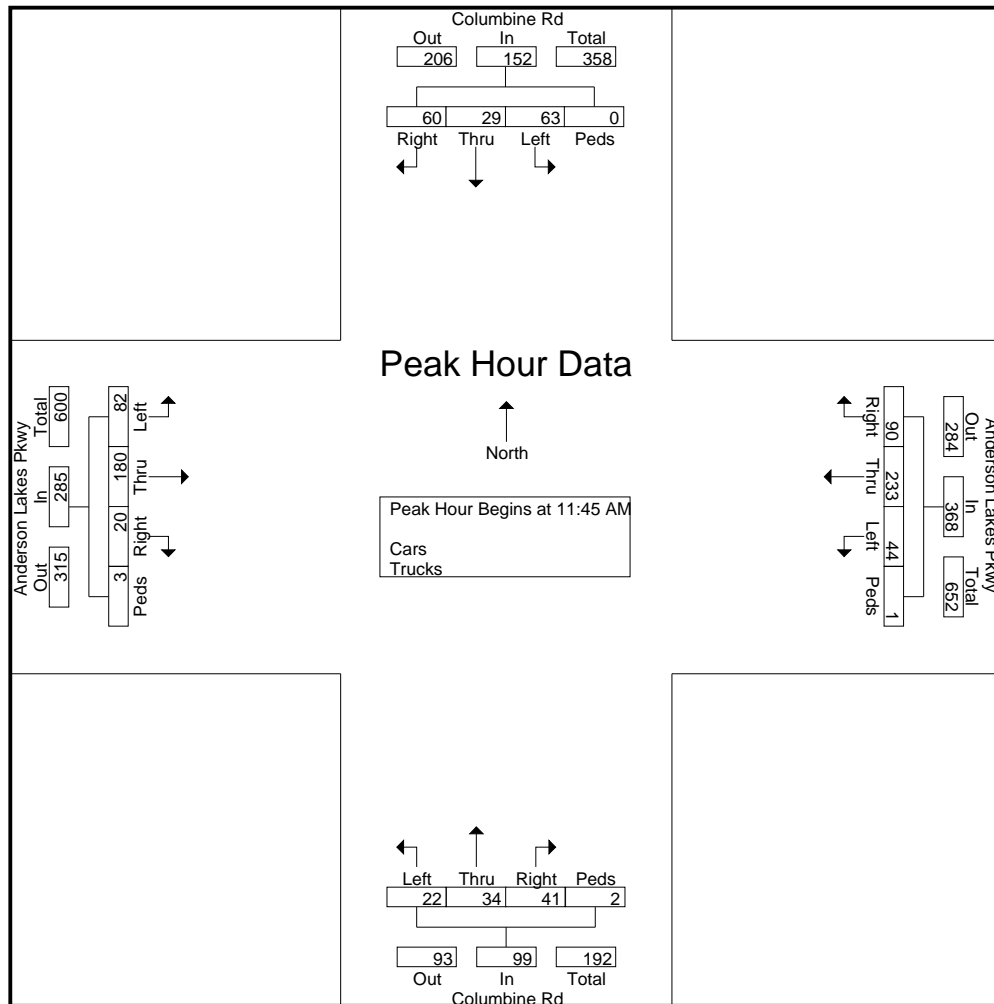

Alliant Engineering, Inc.

733 Marquette Ave #700, Minneapolis, MN 55402

Anderson Lakes Pkwy & Columbine Rd
 Ref Pt:
 data by: Alliant Inc
 TURN MOVEMENT COUNT

File Name : 4_EP_Anderson Lakes Parkway at Columbine Road
 Site Code :
 Start Date : 12/22/2020
 Page No : 5

Start Time	Columbine Rd Southbound					Anderson Lakes Pkwy Westbound					Columbine Rd Northbound					Anderson Lakes Pkwy Eastbound					Int. Total
	Right	Thru	Left	Peds	App. Total	Right	Thru	Left	Peds	App. Total	Right	Thru	Left	Peds	App. Total	Right	Thru	Left	Peds	App. Total	
Peak Hour Analysis From 02:00 PM to 05:45 PM - Peak 1 of 1																					
Peak Hour for Entire Intersection Begins at 04:30 PM																					
04:30 PM	15	6	31	0	52	28	67	9	0	104	8	6	3	0	17	8	59	27	0	94	267
04:45 PM	20	3	22	0	45	29	61	13	0	103	6	8	3	0	17	6	62	35	0	103	268
05:00 PM	14	3	22	0	39	30	49	9	0	88	17	7	3	0	27	6	52	31	0	89	243
05:15 PM	15	6	20	0	41	25	56	11	0	92	11	8	4	0	23	4	66	14	0	84	240
Total Volume	64	18	95	0	177	112	233	42	0	387	42	29	13	0	84	24	239	107	0	370	1018
% App. Total	36.2	10.2	53.7	0		28.9	60.2	10.9	0		50	34.5	15.5	0		6.5	64.6	28.9	0		
PHF	.800	.750	.766	.000	.851	.933	.869	.808	.000	.930	.618	.906	.813	.000	.778	.750	.905	.764	.000	.898	.950

