

Alliant Engineering Inc Minneapolis, MN 55415

Flying Cloud Drive at College View Drive
Eden Prairie
data by : Aliant Engineering
TURN MOVEMENT COUNT

File Name : 02_Flying Cloud Drive at College View Drive
Site Code : 00000002
Start Date : 10/13/2009
Page No : 1

Groups Printed- Unshifted - Bank 1

Start Time	Flying Cloud Drive (TH 212) Southbound				College View Drive Westbound				Flying Cloud Drive (TH 212) Northbound				College View Drive Eastbound				Int. Total
	Left	Thru	Right	Peds	Left	Thru	Right	Peds	Left	Thru	Right	Peds	Left	Thru	Right	Peds	
06:30	0	55	8	0	0	1	9	0	9	152	0	0	0	0	1	0	235
06:45	0	54	21	0	1	1	11	0	19	242	0	0	3	0	1	0	353
Total	0	109	29	0	1	2	20	0	28	394	0	0	3	0	2	0	588
07:00	1	60	25	0	1	1	12	0	29	242	0	0	2	1	7	0	381
07:15	1	73	28	0	0	2	20	0	24	317	0	0	0	1	2	0	468
07:30	2	65	57	0	0	4	30	0	35	397	1	0	4	0	8	0	603
07:45	4	108	52	0	0	7	10	0	57	323	1	0	8	1	8	0	579
Total	8	306	162	0	1	14	72	0	145	1279	2	0	14	3	25	0	2031
08:00	1	47	37	0	0	5	15	0	39	265	2	0	7	0	8	0	426
08:15	0	66	23	0	0	3	9	0	29	249	0	0	5	1	1	1	387
08:30	7	58	28	1	2	5	13	0	28	192	0	0	6	0	1	0	341
08:45	3	51	41	0	0	2	12	0	38	202	0	0	7	0	5	0	361
Total	11	222	129	1	2	15	49	0	134	908	2	0	25	1	15	1	1515
09:00	8	50	12	0	0	1	10	0	31	111	0	0	7	0	3	0	233
09:15	3	50	16	0	1	0	4	0	22	121	0	0	1	0	1	0	219
*** BREAK ***																	
Total	11	100	28	0	1	1	14	0	53	232	0	0	8	0	4	0	452
*** BREAK ***																	
10:30	1	66	12	0	0	0	8	0	7	90	0	0	13	2	9	0	208
10:45	4	74	16	0	0	1	3	0	6	114	0	0	16	1	9	0	244
Total	5	140	28	0	0	1	11	0	13	204	0	0	29	3	18	0	452
11:00	4	73	11	0	0	0	5	0	8	87	2	0	22	1	12	0	225
11:15	5	76	18	0	0	1	7	0	2	130	0	0	16	2	23	0	280
11:30	3	86	25	0	1	2	6	0	15	116	0	0	51	3	36	0	344
11:45	9	92	42	0	1	1	6	0	10	145	0	0	41	2	17	0	366
Total	21	327	96	0	2	4	24	0	35	478	2	0	130	8	88	0	1215
12:00	3	96	24	0	0	1	2	0	12	151	3	0	24	1	15	0	332
12:15	9	145	20	0	0	1	3	0	11	126	0	0	23	1	14	0	353
12:30	4	141	19	0	2	1	3	0	19	123	1	0	22	4	19	0	358
12:45	4	106	31	0	0	4	6	0	18	111	3	0	26	1	8	0	318
Total	20	488	94	0	2	7	14	0	60	511	7	0	95	7	56	0	1361
13:00	6	127	12	0	0	2	14	0	2	134	0	0	21	0	15	0	333
13:15	2	115	10	0	0	1	2	0	12	99	0	0	17	0	16	0	274
*** BREAK ***																	
Total	8	242	22	0	0	3	16	0	14	233	0	0	38	0	31	0	607
*** BREAK ***																	
14:30	2	117	13	0	0	0	4	0	13	111	0	1	33	1	20	0	315
14:45	6	106	23	0	0	0	8	0	12	90	0	0	16	0	13	0	274
Total	8	223	36	0	0	0	12	0	25	201	0	1	49	1	33	0	589
15:00	8	121	14	0	1	2	5	0	13	110	0	1	17	0	17	0	309
15:15	4	146	19	0	1	0	7	0	6	102	0	0	10	1	10	1	307
15:30	6	172	12	0	0	1	4	0	9	127	2	1	16	2	25	0	377
15:45	5	153	20	0	2	2	7	0	8	93	1	0	21	1	20	0	333
Total	23	592	65	0	4	5	23	0	36	432	3	2	64	4	72	1	1326
16:00	5	252	19	0	0	1	4	0	4	118	0	0	21	0	32	0	456
16:15	3	196	29	0	0	1	10	0	16	119	0	0	21	1	19	0	415
16:30	4	274	24	0	1	1	8	0	20	142	1	0	6	2	28	0	511
16:45	15	236	35	0	0	1	7	0	22	120	3	1	12	4	20	0	476
Total	27	958	107	0	1	4	29	0	62	499	4	1	60	7	99	0	1858

Alliant Engineering Inc Minneapolis, MN 55415

Flying Cloud Drive at College View Drive
Eden Prairie
data by : Aliant Engineering
TURN MOVEMENT COUNT

File Name : 02_Flying Cloud Drive at College View Drive
Site Code : 00000002
Start Date : 10/13/2009
Page No : 2

Groups Printed- Unshifted - Bank 1

Start Time	Flying Cloud Drive (TH 212) Southbound				College View Drive Westbound				Flying Cloud Drive (TH 212) Northbound				College View Drive Eastbound				Int. Total
	Left	Thru	Right	Peds	Left	Thru	Right	Peds	Left	Thru	Right	Peds	Left	Thru	Right	Peds	
17:00	12	244	30	0	1	2	6	0	19	142	1	0	17	6	36	0	516
17:15	11	237	29	1	1	3	4	0	29	127	1	0	16	5	28	0	492
17:30	15	218	51	0	0	2	12	0	23	146	0	1	13	3	23	0	507
17:45	10	223	54	0	1	0	4	0	29	113	0	0	11	1	20	0	466
Total	48	922	164	1	3	7	26	0	100	528	2	1	57	15	107	0	1981
18:00	12	128	22	0	0	1	11	0	20	108	1	1	10	1	18	0	333
18:15	13	145	12	0	2	1	8	0	11	105	0	1	10	4	17	0	329
18:30	8	141	5	0	0	0	5	0	4	66	0	0	28	1	36	0	294
18:45	6	121	10	0	2	1	5	0	7	70	0	0	18	1	14	0	255
Total	39	535	49	0	4	3	29	0	42	349	1	2	66	7	85	0	1211
Grand Total	229	5164	1009	2	21	66	339	0	747	6248	23	7	638	56	635	2	15186
Apprch %	3.6	80.6	15.8	0	4.9	15.5	79.6	0	10.6	88.9	0.3	0.1	47.9	4.2	47.7	0.2	
Total %	1.5	34	6.6	0	0.1	0.4	2.2	0	4.9	41.1	0.2	0	4.2	0.4	4.2	0	
Unshifted	227	5103	976	2	20	57	334	0	742	6066	23	7	603	54	625	2	14841
% Unshifted	99.1	98.8	96.7	100	95.2	86.4	98.5	0	99.3	97.1	100	100	94.5	96.4	98.4	100	97.7
Bank 1	2	61	33	0	1	9	5	0	5	182	0	0	35	2	10	0	345
% Bank 1	0.9	1.2	3.3	0	4.8	13.6	1.5	0	0.7	2.9	0	0	5.5	3.6	1.6	0	2.3

Alliant Engineering Inc Minneapolis, MN 55415

Flying Cloud Drive at College View Drive
Eden Prairie
data by : Aliant Engineering
TURN MOVEMENT COUNT

File Name : 02_Flying Cloud Drive at College View Drive
Site Code : 00000002
Start Date : 10/13/2009
Page No : 3

Start Time	Flying Cloud Drive (TH 212) Southbound					College View Drive Westbound					Flying Cloud Drive (TH 212) Northbound					College View Drive Eastbound					Int. Total
	Left	Thru	Right	Peds	App. Total	Left	Thru	Right	Peds	App. Total	Left	Thru	Right	Peds	App. Total	Left	Thru	Right	Peds	App. Total	
Peak Hour Analysis From 06:30 to 09:15 - Peak 1 of 1																					
Peak Hour for Entire Intersection Begins at 07:15																					
07:15	1	73	28	0	102	0	2	20	0	22	24	317	0	0	341	0	1	2	0	3	468
07:30	2	65	57	0	124	0	4	30	0	34	35	397	1	0	433	4	0	8	0	12	603
07:45	4	108	52	0	164	0	7	10	0	17	57	323	1	0	381	8	1	8	0	17	579
08:00	1	47	37	0	85	0	5	15	0	20	39	265	2	0	306	7	0	8	0	15	426
Total Volume	8	293	174	0	475	0	18	75	0	93	155	1302	4	0	1461	19	2	26	0	47	2076
% App. Total	1.7	61.7	36.6	0		0	19.4	80.6	0		10.6	89.1	0.3	0		40.4	4.3	55.3	0		
PHF	.500	.678	.763	.000	.724	.000	.643	.625	.000	.684	.680	.820	.500	.000	.844	.594	.500	.813	.000	.691	.861

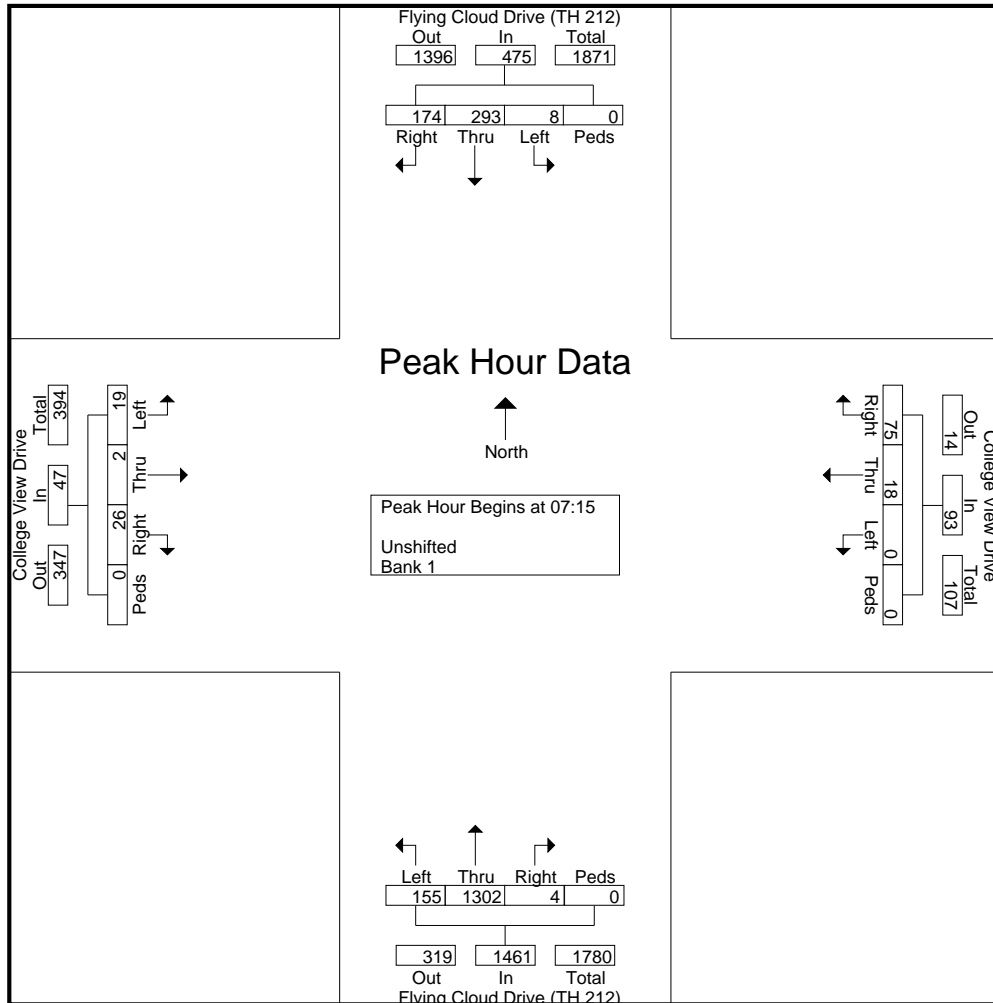

Alliant Engineering Inc Minneapolis, MN 55415

Flying Cloud Drive at College View Drive
Eden Prairie
data by : Aliant Engineering
TURN MOVEMENT COUNT

File Name : 02_Flying Cloud Drive at College View Drive
Site Code : 00000002
Start Date : 10/13/2009
Page No : 4

Start Time	Flying Cloud Drive (TH 212) Southbound					College View Drive Westbound					Flying Cloud Drive (TH 212) Northbound					College View Drive Eastbound					Int. Total
	Left	Thru	Right	Peds	App. Total	Left	Thru	Right	Peds	App. Total	Left	Thru	Right	Peds	App. Total	Left	Thru	Right	Peds	App. Total	
Peak Hour Analysis From 15:00 to 18:45 - Peak 1 of 1																					
Peak Hour for Entire Intersection Begins at 16:30																					
16:30	4	274	24	0	302	1	1	8	0	10	20	142	1	0	163	6	2	28	0	36	511
16:45	15	236	35	0	286	0	1	7	0	8	22	120	3	1	146	12	4	20	0	36	476
17:00	12	244	30	0	286	1	2	6	0	9	19	142	1	0	162	17	6	36	0	59	516
17:15	11	237	29	1	278	1	3	4	0	8	29	127	1	0	157	16	5	28	0	49	492
Total Volume	42	991	118	1	1152	3	7	25	0	35	90	531	6	1	628	51	17	112	0	180	1995
% App. Total	3.6	86	10.2	0.1		8.6	20	71.4	0		14.3	84.6	1	0.2		28.3	9.4	62.2	0		
PHF	.700	.904	.843	.250	.954	.750	.583	.781	.000	.875	.776	.935	.500	.250	.963	.750	.708	.778	.000	.763	.967

