



**MINNESOTA DEPT OF TRANSPORTATION**  
**TRAFFIC DATA COLLECTION - METRO**

Location: TH 101 @ TH 812C 2003  
 REF. PT.: 008+00.837  
 Jamar# 1358/MAR  
 TURN MOVEMENT COUNT

File Name : TH 101 @ TH 812C 2003  
 Site Code : 00000000  
 Start Date : 1/12/2006  
 Page No : 1

Groups Printed- Cars & Trucks

Start Time	TH 812C Southbound					N/A Westbound					TH 101 Northbound					TH 101 Eastbound					Int. Total
	Left	Thru	Right	Peds	App. Total	Left	Thru	Right	Peds	App. Total	Left	Thru	Right	Peds	App. Total	Left	Thru	Right	Peds	App. Total	
06:00	0	4	0	0	4	0	0	0	0	0	86	65	0	0	151	0	1	81	0	82	237
06:15	0	16	0	0	16	0	0	0	0	0	101	119	0	0	220	0	0	143	0	143	379
06:30	0	12	0	0	12	0	0	0	0	0	134	200	0	0	334	0	0	138	0	138	484
06:45	0	25	1	0	26	0	0	0	0	0	142	160	0	0	302	0	0	112	0	112	440
Total	0	57	1	0	58	0	0	0	0	0	463	544	0	0	1007	0	1	474	0	475	1540
07:00	0	7	0	0	7	0	0	0	0	0	160	205	0	0	365	0	0	120	0	120	492
07:15	0	50	0	0	50	0	0	0	0	0	178	193	0	0	371	0	0	175	0	175	596
07:30	0	39	0	0	39	0	0	0	0	0	170	206	0	0	376	0	0	157	0	157	572
07:45	0	32	0	0	32	0	0	0	0	0	197	154	0	0	351	0	0	153	0	153	536
Total	0	128	0	0	128	0	0	0	0	0	705	758	0	0	1463	0	0	605	0	605	2196
08:00	0	30	0	0	30	0	0	0	0	0	124	146	0	0	270	0	0	123	0	123	423
08:15	0	25	0	0	25	0	0	0	0	0	109	104	0	0	213	0	0	114	0	114	352
08:30	0	24	0	0	24	0	0	0	0	0	98	86	0	0	184	0	0	88	0	88	296
08:45	0	30	0	0	30	0	0	0	0	0	93	94	0	0	187	0	0	81	0	81	298
Total	0	109	0	0	109	0	0	0	0	0	424	430	0	0	854	0	0	406	0	406	1369
15:00	0	97	0	0	97	0	0	0	0	0	96	47	0	0	143	0	0	187	0	187	427
15:15	0	81	0	0	81	0	0	0	0	0	140	44	0	0	184	0	0	178	0	178	443
15:30	0	103	0	0	103	0	0	0	0	0	142	62	0	0	204	0	0	163	0	163	470
15:45	0	140	0	0	140	0	0	0	0	0	146	48	0	0	194	0	0	193	0	193	527
Total	0	421	0	0	421	0	0	0	0	0	524	201	0	0	725	0	0	721	0	721	1867
16:00	0	137	0	0	137	0	0	0	0	0	151	56	0	0	207	0	0	195	0	195	539
16:15	0	191	1	0	192	0	0	0	0	0	139	55	0	0	194	0	0	200	0	200	586
16:30	0	167	0	0	167	0	0	0	0	0	198	59	0	0	257	0	0	274	0	274	698
16:45	0	216	0	0	216	0	0	0	0	0	213	55	0	0	268	0	0	254	0	254	738
Total	0	711	1	0	712	0	0	0	0	0	701	225	0	0	926	0	0	923	0	923	2561
17:00	0	190	1	0	191	0	0	0	0	0	202	72	0	0	274	0	0	234	0	234	699
17:15	0	247	0	0	247	0	0	0	0	0	189	62	0	0	251	0	0	284	0	284	782
17:30	0	221	0	0	221	0	0	0	0	0	150	63	0	0	213	0	0	182	0	182	616
17:45	0	175	0	0	175	0	0	0	0	0	189	56	0	0	245	0	0	181	0	181	601
Total	0	833	1	0	834	0	0	0	0	0	730	253	0	0	983	0	0	881	0	881	2698
Grand Total	0	2259	3	0	2262	0	0	0	0	0	3547	2411	0	0	5958	0	1	4010	0	4011	12231
Apprch %	0	99.9	0.1	0		0	0	0	0		59.5	40.5	0	0		0	0	100	0		
Total %	0	18.5	0	0	18.5	0	0	0	0	0	29	19.7	0	0	48.7	0	0	32.8	0	32.8	



# MINNESOTA DEPT OF TRANSPORTATION

## TRAFFIC DATA COLLECTION - METRO

File Name : TH 101 @ TH 812C 2003  
 Site Code : 00000000  
 Start Date : 1/12/2006  
 Page No : 2

Start Time	TH 812C Southbound					N/A Westbound					TH 101 Northbound					TH 101 Eastbound					Int. Total
	Left	Thru	Right	Peds	App. Total	Left	Thru	Right	Peds	App. Total	Left	Thru	Right	Peds	App. Total	Left	Thru	Right	Peds	App. Total	
Peak Hour Analysis From 06:00 to 09:00 - Peak 1 of 1																					
Peak Hour for Entire Intersection Begins at 07:00																					
07:00	0	7	0	0	7	0	0	0	0	0	160	205	0	0	365	0	0	120	0	120	492
07:15	0	<b>50</b>	0	0	<b>50</b>	0	0	0	0	0	178	193	0	0	371	0	0	<b>175</b>	0	<b>175</b>	<b>596</b>
07:30	0	39	0	0	39	0	0	0	0	0	170	<b>206</b>	0	0	<b>376</b>	0	0	157	0	157	572
07:45	0	32	0	0	32	0	0	0	0	0	<b>197</b>	154	0	0	351	0	0	153	0	153	536
Total Volume	0	128	0	0	128	0	0	0	0	0	705	758	0	0	1463	0	0	605	0	605	2196
% App. Total	0	100	0	0		0	0	0	0		48.2	51.8	0	0		0	0	100	0		
PHF	.000	.640	.000	.000	.640	.000	.000	.000	.000	.000	.895	.920	.000	.000	.973	.000	.000	.864	.000	.864	.921

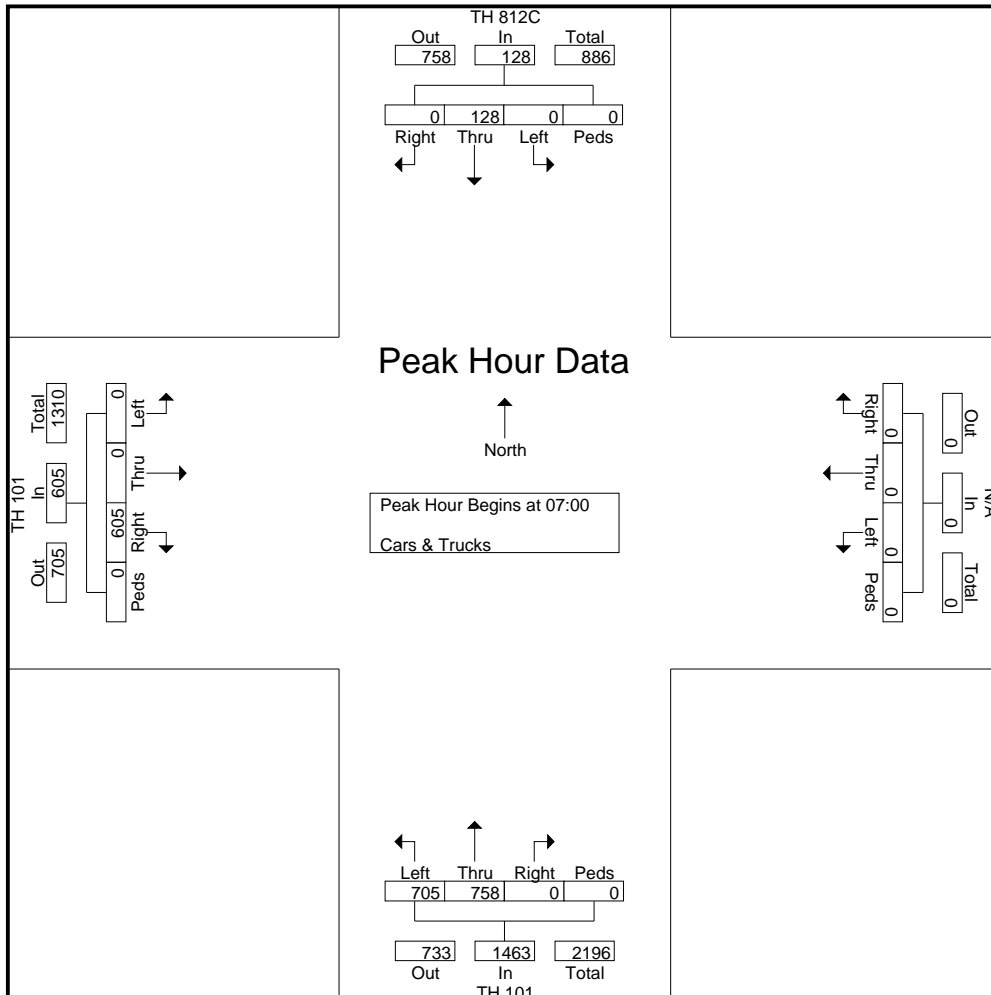



# MINNESOTA DEPT OF TRANSPORTATION

## TRAFFIC DATA COLLECTION - METRO

File Name : TH 101 @ TH 812C 2003  
 Site Code : 00000000  
 Start Date : 1/12/2006  
 Page No : 3

Start Time	TH 812C Southbound					N/A Westbound					TH 101 Northbound					TH 101 Eastbound					Int. Total
	Left	Thru	Right	Peds	App. Total	Left	Thru	Right	Peds	App. Total	Left	Thru	Right	Peds	App. Total	Left	Thru	Right	Peds	App. Total	
16:30	0	167	0	0	167	0	0	0	0	0	198	59	0	0	257	0	0	274	0	274	698
16:45	0	216	0	0	216	0	0	0	0	0	213	55	0	0	268	0	0	254	0	254	738
17:00	0	190	1	0	191	0	0	0	0	0	202	72	0	0	274	0	0	234	0	234	699
17:15	0	247	0	0	247	0	0	0	0	0	189	62	0	0	251	0	0	284	0	284	782
Total Volume	0	820	1	0	821	0	0	0	0	0	802	248	0	0	1050	0	0	1046	0	1046	2917
% App. Total	0	99.9	0.1	0		0	0	0	0		76.4	23.6	0	0		0	0	100	0		
PHF	.000	.830	.250	.000	.831	.000	.000	.000	.000	.000	.941	.861	.000	.000	.958	.000	.000	.921	.000	.921	.933

Peak Hour Analysis From 15:00 to 17:45 - Peak 1 of 1  
 Peak Hour for Entire Intersection Begins at 16:30

