

Alliant Engineering

Minneapolis, MN 55415

--TRAFFIC DATA --

TH-169 at School Street, ELK RIVER

Ref.Pt.:

Alliant Eng.

TURN MOVEMENT COUNT

File Name : 414_TH 169 & School St

Site Code : 414

Start Date : 3/3/2016

Page No : 1

Groups Printed- Vehicles - Trucks

Start Time	TH-169 Southbound				School Street Westbound				TH-169 Northbound				School Street Eastbound				Int. Total
	Left	Thru	Rght	Other	Left	Thru	Rght	Other	Left	Thru	Rght	Other	Left	Thru	Rght	Other	
06:00	4	379	1	0	17	5	2	0	13	55	1	0	4	9	36	0	526
06:15	9	461	2	0	14	9	1	0	17	82	0	0	1	4	24	0	624
06:30	7	494	4	0	38	21	3	0	14	81	0	0	3	14	60	0	739
06:45	8	365	8	0	33	36	4	0	45	84	0	0	5	10	43	0	641
Total	28	1699	15	0	102	71	10	0	89	302	1	0	13	37	163	0	2530
07:00	7	413	5	0	27	37	2	0	55	139	0	0	4	14	61	0	764
07:15	13	439	3	0	27	38	5	0	72	124	0	0	12	31	63	0	827
07:30	16	431	11	0	21	26	12	0	45	126	0	0	5	25	52	0	770
07:45	5	409	11	0	24	35	13	0	49	159	0	0	10	25	47	0	787
Total	41	1692	30	0	99	136	32	0	221	548	0	0	31	95	223	0	3148
08:00	11	270	15	0	23	33	12	0	42	87	0	0	11	25	72	0	601
08:15	7	338	6	0	23	21	8	0	35	109	0	0	8	15	28	0	598
08:30	19	312	7	0	21	15	8	0	25	106	0	0	14	14	34	0	575
08:45	6	268	14	0	24	37	7	0	47	131	1	0	7	21	33	0	596
Total	43	1188	42	0	91	106	35	0	149	433	1	0	40	75	167	0	2370
09:00	10	206	12	0	18	27	11	0	47	102	1	0	10	32	57	0	533
09:15	10	166	7	0	13	26	4	0	46	117	0	0	11	35	33	0	468
*** BREAK ***																	
Total	20	372	19	0	31	53	15	0	93	219	1	0	21	67	90	0	1001
*** BREAK ***																	
10:30	8	249	8	0	15	18	8	0	39	153	0	0	14	9	32	0	553
10:45	11	181	9	0	6	22	7	0	43	136	0	0	10	23	41	0	489
Total	19	430	17	0	21	40	15	0	82	289	0	0	24	32	73	0	1042
11:00	9	174	4	0	10	28	9	0	53	163	0	0	11	24	36	0	521
11:15	12	190	7	0	13	26	11	0	62	167	0	0	6	27	17	0	538
11:30	13	198	9	1	11	29	12	1	77	153	0	0	14	39	42	0	599
11:45	7	169	10	0	9	18	3	0	75	168	0	0	10	26	47	0	542
Total	41	731	30	1	43	101	35	1	267	651	0	0	41	116	142	0	2200
12:00	16	196	6	0	13	28	11	0	73	133	0	0	11	23	45	0	555
12:15	8	203	10	2	19	26	14	0	69	174	0	0	13	18	45	0	601
12:30	11	171	7	1	16	35	15	0	38	177	0	0	20	27	45	0	563
12:45	11	186	12	0	10	29	20	0	64	167	0	0	8	20	33	0	560
Total	46	756	35	3	58	118	60	0	244	651	0	0	52	88	168	0	2279
13:00	16	173	7	1	9	24	13	0	49	189	0	0	6	19	43	0	549
13:15	12	213	5	0	21	21	13	0	59	224	0	0	13	23	63	0	667
*** BREAK ***																	
Total	28	386	12	1	30	45	26	0	108	413	0	0	19	42	106	0	1216
*** BREAK ***																	
14:30	12	231	6	0	14	32	13	0	77	280	0	0	18	44	55	0	782
14:45	18	209	11	0	6	37	8	0	62	324	0	0	14	30	27	0	746
Total	30	440	17	0	20	69	21	0	139	604	0	0	32	74	82	0	1528
15:00	10	162	14	0	10	41	12	0	88	348	0	0	21	41	59	0	806
15:15	17	213	12	0	14	38	12	0	65	336	0	0	22	32	65	0	826
15:30	7	208	9	0	9	34	14	0	119	438	0	0	26	30	35	0	929
15:45	19	163	12	0	10	40	16	0	100	453	0	0	27	50	61	0	951
Total	53	746	47	0	43	153	54	0	372	1575	0	0	96	153	220	0	3512
16:00	10	239	5	0	7	34	19	0	96	485	0	0	33	43	64	0	1035
16:15	14	206	9	0	15	51	17	0	125	517	0	0	28	34	41	0	1057
16:30	13	215	7	0	15	38	24	0	97	514	0	0	33	33	71	0	1060

Alliant Engineering

Minneapolis, MN 55415

--TRAFFIC DATA --

TH-169 at School Street, ELK RIVER

Ref.Pt.:

Alliant Eng.

TURN MOVEMENT COUNT

File Name : 414_TH 169 & School St

Site Code : 414

Start Date : 3/3/2016

Page No : 2

Groups Printed- Vehicles - Trucks

Start Time	TH-169 Southbound				School Street Westbound				TH-169 Northbound				School Street Eastbound				Int. Total
	Left	Thru	Rght	Other	Left	Thru	Rght	Other	Left	Thru	Rght	Other	Left	Thru	Rght	Other	
16:45	16	205	14	0	14	56	23	0	169	499	0	0	46	37	31	0	1110
Total	53	865	35	0	51	179	83	0	487	2015	0	0	140	147	207	0	4262
17:00	14	214	6	0	17	51	22	0	126	498	0	0	40	83	63	0	1134
17:15	16	205	11	1	11	46	15	0	139	435	0	0	24	49	47	0	999
17:30	12	181	9	0	24	49	15	0	127	421	0	0	27	27	58	0	950
17:45	20	200	8	0	17	48	16	0	120	413	0	0	25	32	74	0	973
Total	62	800	34	1	69	194	68	0	512	1767	0	0	116	191	242	0	4056
Grand Total	464	10105	333	6	658	1265	454	1	2763	9467	3	0	625	1117	1883	0	29144
Apprch %	4.3	92.6	3.1	0.1	27.7	53.2	19.1	0	22.6	77.4	0	0	17.2	30.8	51.9	0	
Total %	1.6	34.7	1.1	0	2.3	4.3	1.6	0	9.5	32.5	0	0	2.1	3.8	6.5	0	
Vehicles	458	9632	323	6	652	1219	442	1	2697	9040	3	0	611	1092	1819	0	27995
% Vehicles	98.7	95.3	97	100	99.1	96.4	97.4	100	97.6	95.5	100	0	97.8	97.8	96.6	0	96.1
Trucks	6	473	10	0	6	46	12	0	66	427	0	0	14	25	64	0	1149
% Trucks	1.3	4.7	3	0	0.9	3.6	2.6	0	2.4	4.5	0	0	2.2	2.2	3.4	0	3.9

Alliant Engineering

Minneapolis, MN 55415

--TRAFFIC DATA --

TH-169 at School Street, ELK RIVER

Ref.Pt.:

Alliant Eng.

TURN MOVEMENT COUNT

File Name : 414_TH 169 & School St

Site Code : 414

Start Date : 3/3/2016

Page No : 3

Start Time	TH-169 Southbound					School Street Westbound					TH-169 Northbound					School Street Eastbound					Int. Total
	Left	Thru	Right	Other	App. Total	Left	Thru	Right	Other	App. Total	Left	Thru	Right	Other	App. Total	Left	Thru	Right	Other	App. Total	
Peak Hour Analysis From 06:00 to 11:45 - Peak 1 of 1																					
Peak Hour for Entire Intersection Begins at 07:00																					
07:00	7	413	5	0	425	27	37	2	0	66	55	139	0	0	194	4	14	61	0	79	764
07:15	13	439	3	0	455	27	38	5	0	70	72	124	0	0	196	12	31	63	0	106	827
07:30	16	431	11	0	458	21	26	12	0	59	45	126	0	0	171	5	25	52	0	82	770
07:45	5	409	11	0	425	24	35	13	0	72	49	159	0	0	208	10	25	47	0	82	787
Total Volume	41	1692	30	0	1763	99	136	32	0	267	221	548	0	0	769	31	95	223	0	349	3148
% App. Total	2.3	96	1.7	0		37.1	50.9	12	0		28.7	71.3	0	0		8.9	27.2	63.9	0		
PHF	.641	.964	.682	.000	.962	.917	.895	.615	.000	.927	.767	.862	.000	.000	.924	.646	.766	.885	.000	.823	.952

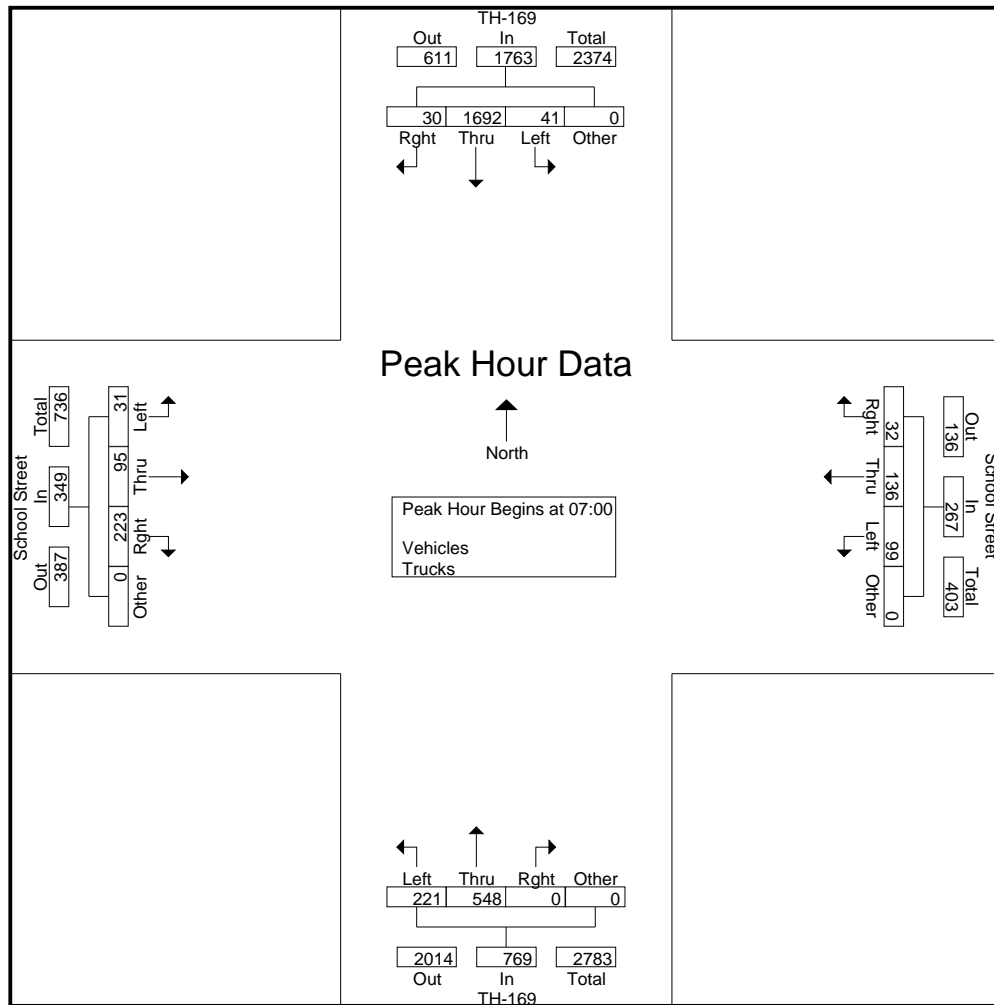

Alliant Engineering

Minneapolis, MN 55415

--TRAFFIC DATA --

TH-169 at School Street, ELK RIVER

Ref.Pt.:

Alliant Eng.

TURN MOVEMENT COUNT

File Name : 414_TH 169 & School St

Site Code : 414

Start Date : 3/3/2016

Page No : 4

Start Time	TH-169 Southbound					School Street Westbound					TH-169 Northbound					School Street Eastbound					Int. Total
	Left	Thru	Rght	Other	App. Total	Left	Thru	Rght	Other	App. Total	Left	Thru	Rght	Other	App. Total	Left	Thru	Rght	Other	App. Total	
Peak Hour Analysis From 12:00 to 17:45 - Peak 1 of 1																					
Peak Hour for Entire Intersection Begins at 16:15																					
16:15	14	206	9	0	229	15	51	17	0	83	125	517	0	0	642	28	34	41	0	103	1057
16:30	13	215	7	0	235	15	38	24	0	77	97	514	0	0	611	33	33	71	0	137	1060
16:45	16	205	14	0	235	14	56	23	0	93	169	499	0	0	668	46	37	31	0	114	1110
17:00	14	214	6	0	234	17	51	22	0	90	126	498	0	0	624	40	83	63	0	186	1134
Total Volume	57	840	36	0	933	61	196	86	0	343	517	2028	0	0	2545	147	187	206	0	540	4361
% App. Total	6.1	90	3.9	0		17.8	57.1	25.1	0		20.3	79.7	0	0		27.2	34.6	38.1	0		
PHF	.891	.977	.643	.000	.993	.897	.875	.896	.000	.922	.765	.981	.000	.000	.952	.799	.563	.725	.000	.726	.961

