

Alliant Engineering

Minneapolis, MN 55415

--TRAFFIC DATA --

TH-169 at Main Ave ELK RIVER

Ref.Pt.:

Alliant Eng.

TURN MOVEMENT COUNT

File Name : 412_TH 169 & Main Ave

Site Code : 412

Start Date : 3/8/2016

Page No : 1

Groups Printed- Vehicles - Trucks

Start Time	TH-169 Southbound				Main Ave Westbound				TH-169 Northbound				Main Ave Eastbound				Int. Total
	Left	Thru	Rght	Other	Left	Thru	Rght	Other	Left	Thru	Rght	Other	Left	Thru	Rght	Other	
06:00	29	389	16	0	58	37	8	0	1	68	20	0	2	11	22	0	661
06:15	37	422	14	0	78	49	14	0	12	75	26	0	2	11	16	0	756
06:30	55	448	24	0	90	42	19	0	8	65	26	0	3	48	3	0	831
06:45	51	443	15	0	112	49	13	0	5	96	34	0	7	40	5	0	870
Total	172	1702	69	0	338	177	54	0	26	304	106	0	14	110	46	0	3118
07:00	66	405	21	0	104	57	22	0	2	73	16	0	6	26	0	0	798
07:15	72	504	31	0	119	70	43	0	7	98	20	0	5	55	9	0	1033
07:30	60	512	31	0	114	74	47	0	19	133	67	0	10	39	13	0	1119
07:45	82	450	21	0	63	104	30	0	21	62	26	0	25	72	14	0	970
Total	280	1871	104	0	400	305	142	0	49	366	129	0	46	192	36	0	3920
08:00	73	431	33	0	109	68	13	0	16	120	47	0	16	65	2	0	993
08:15	50	350	22	0	87	56	19	0	22	110	24	0	19	49	7	0	815
08:30	56	329	28	0	86	72	12	0	19	109	18	0	15	35	8	0	787
08:45	35	280	33	0	80	50	25	0	25	93	10	0	9	42	10	0	692
Total	214	1390	116	0	362	246	69	0	82	432	99	0	59	191	27	0	3287
09:00	49	263	18	0	60	81	33	0	29	111	35	0	11	68	6	0	764
09:15	66	212	28	0	81	81	16	0	20	138	22	0	11	54	18	0	747
*** BREAK ***																	
Total	115	475	46	0	141	162	49	0	49	249	57	0	22	122	24	0	1511
*** BREAK ***																	
10:30	39	212	22	0	35	85	23	0	12	119	29	0	8	66	6	0	656
10:45	67	211	18	0	41	84	40	0	18	138	35	0	15	45	13	0	725
Total	106	423	40	0	76	169	63	0	30	257	64	0	23	111	19	0	1381
11:00	40	196	19	0	55	70	26	0	26	201	58	0	13	69	11	0	784
11:15	58	194	21	0	40	80	34	0	35	177	26	0	25	94	10	0	794
11:30	46	195	18	0	57	89	38	0	28	172	44	0	15	116	14	0	832
11:45	62	195	18	0	56	112	46	0	31	178	35	0	18	84	10	0	845
Total	206	780	76	0	208	351	144	0	120	728	163	0	71	363	45	0	3255
12:00	42	219	22	0	32	79	6	0	39	161	33	0	31	81	12	0	757
12:15	46	184	23	0	44	118	74	0	36	144	23	0	18	76	12	0	798
12:30	36	232	14	0	55	75	45	0	30	134	39	0	21	93	17	0	791
12:45	57	205	27	0	58	70	55	0	24	142	32	0	30	91	17	0	808
Total	181	840	86	0	189	342	180	0	129	581	127	0	100	341	58	0	3154
13:00	57	217	21	0	51	97	27	0	28	209	30	0	18	103	20	0	878
13:15	60	215	18	0	55	62	43	0	34	204	54	0	28	111	5	0	889
*** BREAK ***																	
Total	117	432	39	0	106	159	70	0	62	413	84	0	46	214	25	0	1767
*** BREAK ***																	
14:30	60	170	17	0	44	63	63	0	41	250	46	0	36	73	19	0	882
14:45	67	177	10	0	49	67	69	0	40	294	59	0	34	82	14	0	962
Total	127	347	27	0	93	130	132	0	81	544	105	0	70	155	33	0	1844
15:00	80	167	27	0	35	74	33	0	49	288	76	0	18	69	14	0	930
15:15	42	182	13	0	53	82	43	0	31	242	57	0	44	86	21	0	896
15:30	73	214	16	0	51	76	57	0	43	327	120	0	25	64	5	0	1071
15:45	63	225	22	0	58	90	51	0	36	269	66	0	38	88	2	0	1008
Total	258	788	78	0	197	322	184	0	159	1126	319	0	125	307	42	0	3905
16:00	56	207	26	0	48	73	41	0	58	447	147	0	35	77	20	0	1235
16:15	75	213	9	0	58	89	49	0	70	479	138	0	36	75	10	0	1301
16:30	61	235	25	0	56	91	53	0	38	505	156	0	28	72	4	0	1324

Alliant Engineering

Minneapolis, MN 55415

--TRAFFIC DATA --

TH-169 at Main Ave ELK RIVER

Ref.Pt.:

Alliant Eng.

TURN MOVEMENT COUNT

File Name : 412_TH 169 & Main Ave

Site Code : 412

Start Date : 3/8/2016

Page No : 2

Groups Printed- Vehicles - Trucks

Start Time	TH-169 Southbound				Main Ave Westbound				TH-169 Northbound				Main Ave Eastbound				Int. Total
	Left	Thru	Rght	Other	Left	Thru	Rght	Other	Left	Thru	Rght	Other	Left	Thru	Rght	Other	
16:45	81	194	20	0	53	89	60	0	55	471	194	0	35	84	12	0	1348
Total	273	849	80	0	215	342	203	0	221	1902	635	0	134	308	46	0	5208
17:00	79	203	17	0	59	89	77	0	55	435	112	0	41	85	5	0	1257
17:15	50	205	23	0	46	96	60	0	70	474	113	0	39	67	0	0	1243
17:30	62	183	14	0	42	87	73	0	62	510	163	0	49	80	17	0	1342
17:45	67	179	26	0	47	82	60	0	55	471	169	0	56	76	11	0	1299
Total	258	770	80	0	194	354	270	0	242	1890	557	0	185	308	33	0	5141
Grand Total	2307	10667	841	0	2519	3059	1560	0	1250	8792	2445	0	895	2722	434	0	37491
Apprch %	16.7	77.2	6.1	0	35.3	42.9	21.9	0	10	70.4	19.6	0	22.1	67.2	10.7	0	
Total %	6.2	28.5	2.2	0	6.7	8.2	4.2	0	3.3	23.5	6.5	0	2.4	7.3	1.2	0	
Vehicles	2251	10384	837	0	2452	3004	1539	0	1235	8521	2400	0	885	2687	427	0	36622
% Vehicles	97.6	97.3	99.5	0	97.3	98.2	98.7	0	98.8	96.9	98.2	0	98.9	98.7	98.4	0	97.7
Trucks	56	283	4	0	67	55	21	0	15	271	45	0	10	35	7	0	869
% Trucks	2.4	2.7	0.5	0	2.7	1.8	1.3	0	1.2	3.1	1.8	0	1.1	1.3	1.6	0	2.3

Alliant Engineering

Minneapolis, MN 55415

--TRAFFIC DATA --

TH-169 at Main Ave ELK RIVER

Ref.Pt.:

Alliant Eng.

TURN MOVEMENT COUNT

File Name : 412_TH 169 & Main Ave

Site Code : 412

Start Date : 3/8/2016

Page No : 3

Start Time	TH-169 Southbound					Main Ave Westbound					TH-169 Northbound					Main Ave Eastbound					Int. Total
	Left	Thru	Rght	Other	App. Total	Left	Thru	Rght	Other	App. Total	Left	Thru	Rght	Other	App. Total	Left	Thru	Rght	Other	App. Total	
Peak Hour Analysis From 06:00 to 11:45 - Peak 1 of 1																					
Peak Hour for Entire Intersection Begins at 07:15																					
07:15	72	504	31	0	607	119	70	43	0	232	7	98	20	0	125	5	55	9	0	69	1033
07:30	60	512	31	0	603	114	74	47	0	235	19	133	67	0	219	10	39	13	0	62	1119
07:45	82	450	21	0	553	63	104	30	0	197	21	62	26	0	109	25	72	14	0	111	970
08:00	73	431	33	0	537	109	68	13	0	190	16	120	47	0	183	16	65	2	0	83	993
Total Volume	287	1897	116	0	2300	405	316	133	0	854	63	413	160	0	636	56	231	38	0	325	4115
% App. Total	12.5	82.5	5	0		47.4	37	15.6	0		9.9	64.9	25.2	0		17.2	71.1	11.7	0		
PHF	.875	.926	.879	.000	.947	.851	.760	.707	.000	.909	.750	.776	.597	.000	.726	.560	.802	.679	.000	.732	.919

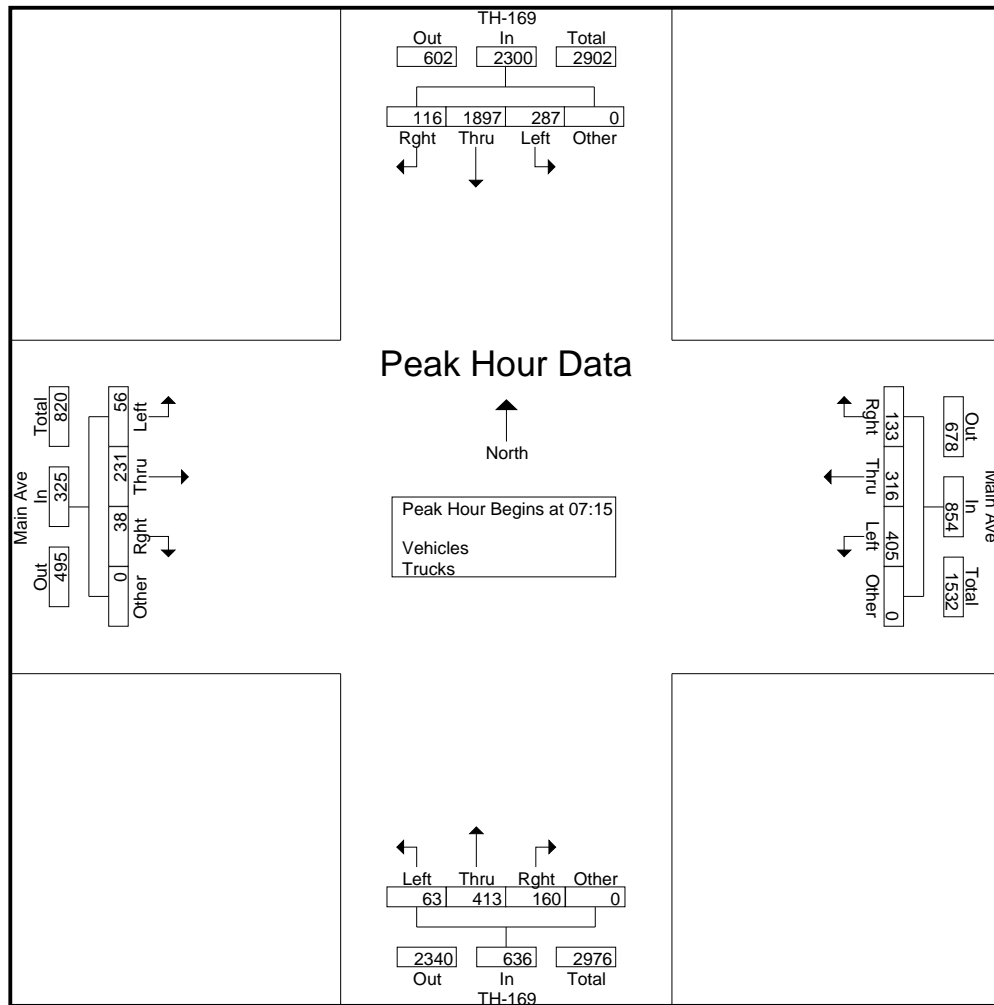

Alliant Engineering

Minneapolis, MN 55415

--TRAFFIC DATA --

TH-169 at Main Ave ELK RIVER

Ref.Pt.:

Alliant Eng.

TURN MOVEMENT COUNT

File Name : 412_TH 169 & Main Ave

Site Code : 412

Start Date : 3/8/2016

Page No : 4

Start Time	TH-169 Southbound					Main Ave Westbound					TH-169 Northbound					Main Ave Eastbound					Int. Total
	Left	Thru	Rght	Other	App. Total	Left	Thru	Rght	Other	App. Total	Left	Thru	Rght	Other	App. Total	Left	Thru	Rght	Other	App. Total	
Peak Hour Analysis From 12:00 to 17:45 - Peak 1 of 1																					
Peak Hour for Entire Intersection Begins at 16:15																					
16:15	75	213	9	0	297	58	89	49	0	196	70	479	138	0	687	36	75	10	0	121	1301
16:30	61	235	25	0	321	56	91	53	0	200	38	505	156	0	699	28	72	4	0	104	1324
16:45	81	194	20	0	295	53	89	60	0	202	55	471	194	0	720	35	84	12	0	131	1348
17:00	79	203	17	0	299	59	89	77	0	225	55	435	112	0	602	41	85	5	0	131	1257
Total Volume	296	845	71	0	1212	226	358	239	0	823	218	1890	600	0	2708	140	316	31	0	487	5230
% App. Total	24.4	69.7	5.9	0		27.5	43.5	29	0		8.1	69.8	22.2	0		28.7	64.9	6.4	0		
PHF	.914	.899	.710	.000	.944	.958	.984	.776	.000	.914	.779	.936	.773	.000	.940	.854	.929	.646	.000	.929	.970

