



# MINNESOTA DEPT OF TRANSPORTATION

## TRAFFIC DATA COLLECTION - METRO

TH-169 at 93rd Ave N /CSAH-30 / 7th St N  
 Ref.Pt.: 140.790  
 JAMAR # 631 / T2638 BR/CP/RE/CAH  
 TURN MOVEMENT COUNT

File Name : TH-169 at 93rd Ave N CSAH-30 2011  
 Site Code : 00000000  
 Start Date : 5/24/2011  
 Page No : 1

### Groups Printed- Cars & Trucks

Start Time	TH-169 Southbound				93rd Ave N / CSAH-30 Westbound				TH-169 Northbound				7th St N Eastbound				Int. Total
	Left	Thru	Right	Peds	Left	Thru	Right	Peds	Left	Thru	Right	Peds	Left	Thru	Right	Peds	
06:00	7	622	30	0	45	24	1	0	8	148	10	0	42	16	13	0	966
06:15	8	603	21	0	72	50	5	0	1	192	32	0	51	16	27	0	1078
06:30	13	657	26	0	75	48	4	0	3	239	39	0	58	41	28	0	1231
06:45	7	672	23	0	64	42	1	0	7	256	35	0	66	43	39	0	1255
Total	35	2554	100	0	256	164	11	0	19	835	116	0	217	116	107	0	4530
07:00	5	579	36	0	57	50	3	0	11	285	30	0	60	32	44	0	1192
07:15	10	665	34	0	50	34	4	0	14	326	35	0	70	61	49	0	1352
07:30	15	556	46	0	58	49	4	0	12	396	44	0	55	63	26	0	1324
07:45	11	500	45	0	45	43	2	0	9	352	85	0	73	74	17	0	1256
Total	41	2300	161	0	210	176	13	0	46	1359	194	0	258	230	136	0	5124
08:00	14	570	45	0	55	30	4	0	15	312	48	1	72	48	22	0	1236
08:15	16	514	56	0	51	36	4	0	14	272	20	0	58	45	13	0	1099
08:30	4	512	60	0	44	29	8	0	14	254	37	0	62	33	16	0	1073
08:45	14	431	47	0	29	14	5	0	7	235	23	0	56	19	21	0	901
Total	48	2027	208	0	179	109	21	0	50	1073	128	1	248	145	72	0	4309
09:00	15	434	54	0	28	24	1	0	14	264	27	0	66	41	23	0	991
09:15	13	442	50	0	36	24	5	0	12	291	23	0	47	35	15	0	993
09:30	11	5	68	0	25	30	8	0	10	237	23	0	50	19	15	0	501
09:45	11	309	51	0	19	15	7	0	12	255	37	0	56	18	10	0	800
Total	50	1190	223	0	108	93	21	0	48	1047	110	0	219	113	63	0	3285
10:00	9	366	61	0	13	16	8	0	19	210	34	0	51	25	13	1	826
10:15	6	340	53	0	13	24	6	0	16	206	15	0	51	25	7	0	762
10:30	12	285	35	0	17	32	2	0	15	265	19	0	58	27	10	0	777
10:45	9	310	57	0	27	23	8	0	19	259	30	0	50	20	12	0	824
Total	36	1301	206	0	70	95	24	0	69	940	98	0	210	97	42	1	3189
11:00	10	367	57	0	26	29	13	0	25	240	17	0	42	26	12	0	864
11:15	13	297	61	0	25	21	16	0	16	267	34	0	53	34	11	0	848
11:30	13	358	63	0	27	34	10	0	15	261	23	0	54	28	14	0	900
11:45	12	297	61	0	30	32	11	0	23	290	36	2	50	43	12	0	899
Total	48	1319	242	0	108	116	50	0	79	1058	110	2	199	131	49	0	3511
12:00	15	334	56	0	18	18	9	0	21	306	25	0	51	38	5	0	896
12:15	16	309	40	0	25	30	11	0	13	280	26	0	47	32	15	1	845
12:30	12	374	52	0	20	29	13	0	20	310	38	0	58	40	12	0	978
12:45	12	278	49	0	22	16	11	2	22	310	20	0	51	46	12	0	851
Total	55	1295	197	0	85	93	44	2	76	1206	109	0	207	156	44	1	3570
13:00	16	332	69	0	26	29	6	0	25	299	33	0	49	34	13	0	931
13:15	17	352	45	0	34	40	3	0	19	337	30	0	54	27	10	0	968
13:30	16	363	63	0	24	37	13	0	27	369	30	0	71	47	15	1	1076
13:45	9	262	54	0	29	31	7	0	23	369	39	0	68	60	9	0	960
Total	58	1309	231	0	113	137	29	0	94	1374	132	0	242	168	47	1	3935
14:00	12	441	67	0	21	30	7	0	34	398	35	0	64	56	16	0	1181
14:15	7	332	76	0	32	42	10	0	24	380	43	0	69	58	12	0	1085
14:30	10	323	79	0	15	26	8	0	43	389	57	0	52	45	8	0	1055
14:45	11	370	64	0	29	41	11	0	24	469	34	0	74	79	16	0	1222
Total	40	1466	286	0	97	139	36	0	125	1636	169	0	259	238	52	0	4543



# MINNESOTA DEPT OF TRANSPORTATION

## TRAFFIC DATA COLLECTION - METRO

TH-169 at 93rd Ave N /CSAH-30 / 7th St N  
 Ref.Pt.: 140.790  
 JAMAR # 631 / T2638 BR/CP/RE/CAH  
 TURN MOVEMENT COUNT

File Name : TH-169 at 93rd Ave N CSAH-30 2011  
 Site Code : 00000000  
 Start Date : 5/24/2011  
 Page No : 2

### Groups Printed- Cars & Trucks

Start Time	TH-169 Southbound				93rd Ave N / CSAH-30 Westbound				TH-169 Northbound				7th St N Eastbound				Int. Total
	Left	Thru	Right	Peds	Left	Thru	Right	Peds	Left	Thru	Right	Peds	Left	Thru	Right	Peds	
15:00	10	300	71	0	39	39	15	0	23	635	32	1	66	42	9	0	1282
15:15	10	445	99	0	40	27	14	0	21	595	30	0	74	74	18	1	1448
15:30	14	362	79	0	37	26	17	0	8	601	23	0	78	46	15	0	1306
15:45	7	403	116	0	30	31	9	0	20	621	25	0	61	43	13	0	1379
Total	41	1510	365	0	146	123	55	0	72	2452	110	1	279	205	55	1	5415
16:00	11	449	102	0	41	40	12	0	11	572	31	0	83	59	3	0	1414
16:15	13	428	82	0	67	41	9	0	8	657	15	0	59	44	8	0	1431
16:30	11	506	110	0	44	47	2	0	3	503	19	0	93	63	6	0	1407
16:45	16	461	104	0	63	43	10	0	18	620	19	0	65	33	8	0	1460
Total	51	1844	398	0	215	171	33	0	40	2352	84	0	300	199	25	0	5712
17:00	8	472	91	0	53	30	8	0	10	631	11	0	63	44	14	0	1435
17:15	9	486	105	0	33	44	11	0	7	584	20	0	78	81	16	0	1474
17:30	5	321	107	0	32	29	9	0	11	664	17	0	63	43	20	0	1321
17:45	9	396	87	0	24	33	5	0	24	596	28	0	78	51	5	0	1336
Total	31	1675	390	0	142	136	33	0	52	2475	76	0	282	219	55	0	5566
Grand Total	534	19790	3007	0	1729	1552	370	2	770	17807	1436	4	2920	2017	747	4	52689
Apprch %	2.3	84.8	12.9	0	47.3	42.5	10.1	0.1	3.8	89	7.2	0	51.3	35.5	13.1	0.1	
Total %	1	37.6	5.7	0	3.3	2.9	0.7	0	1.5	33.8	2.7	0	5.5	3.8	1.4	0	



# MINNESOTA DEPT OF TRANSPORTATION

## TRAFFIC DATA COLLECTION - METRO

TH-169 at 93rd Ave N /CSAH-30 / 7th St N  
 Ref.Pt.: 140.790  
 JAMAR # 631 / T2638 BR/CP/RE/CAH  
 TURN MOVEMENT COUNT

File Name : TH-169 at 93rd Ave N CSAH-30 2011  
 Site Code : 00000000  
 Start Date : 5/24/2011  
 Page No : 3

Start Time	TH-169 Southbound					93rd Ave N / CSAH-30 Westbound					TH-169 Northbound					7th St N Eastbound					Int. Total
	Left	Thru	Right	Peds	App. Total	Left	Thru	Right	Peds	App. Total	Left	Thru	Right	Peds	App. Total	Left	Thru	Right	Peds	App. Total	
Peak Hour Analysis From 06:00 to 08:45 - Peak 1 of 1																					
Peak Hour for Entire Intersection Begins at 07:15																					
07:15	10	665	34	0	709	50	34	4	0	88	14	326	35	0	375	70	61	49	0	180	1352
07:30	15	556	46	0	617	58	49	4	0	111	12	396	44	0	452	55	63	26	0	144	1324
07:45	11	500	45	0	556	45	43	2	0	90	9	352	85	0	446	73	74	17	0	164	1256
08:00	14	570	45	0	629	55	30	4	0	89	15	312	48	1	376	72	48	22	0	142	1236
Total Volume	50	2291	170	0	2511	208	156	14	0	378	50	1386	212	1	1649	270	246	114	0	630	5168
% App. Total	2	91.2	6.8	0		55	41.3	3.7	0		3	84.1	12.9	0.1		42.9	39	18.1	0		
PHF	.833	.861	.924	.000	.885	.897	.796	.875	.000	.851	.833	.875	.624	.250	.912	.925	.831	.582	.000	.875	.956

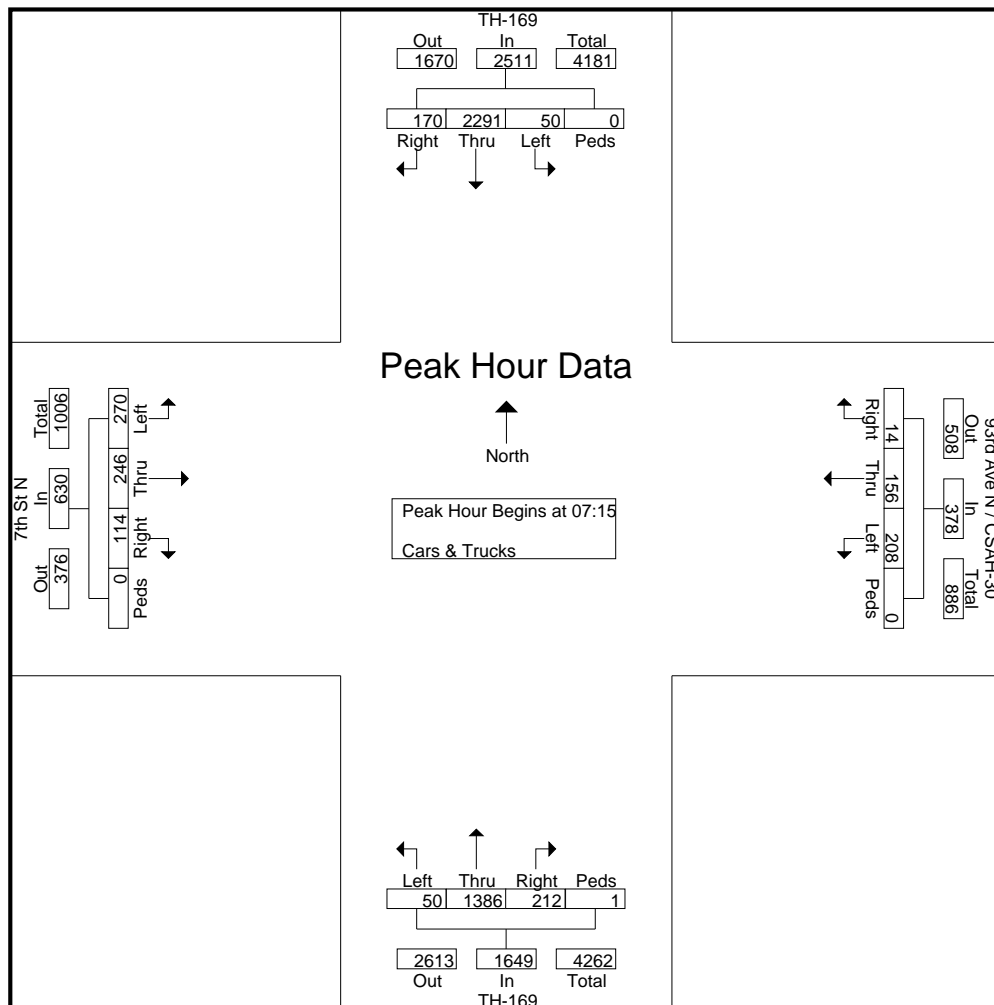



# MINNESOTA DEPT OF TRANSPORTATION

## TRAFFIC DATA COLLECTION - METRO

TH-169 at 93rd Ave N /CSAH-30 / 7th St N  
 Ref.Pt.: 140.790  
 JAMAR # 631 / T2638 BR/CP/RE/CAH  
 TURN MOVEMENT COUNT

File Name : TH-169 at 93rd Ave N CSAH-30 2011  
 Site Code : 00000000  
 Start Date : 5/24/2011  
 Page No : 4

Start Time	TH-169 Southbound					93rd Ave N / CSAH-30 Westbound					TH-169 Northbound					7th St N Eastbound					Int. Total
	Left	Thru	Right	Peds	App. Total	Left	Thru	Right	Peds	App. Total	Left	Thru	Right	Peds	App. Total	Left	Thru	Right	Peds	App. Total	
Peak Hour Analysis From 15:00 to 17:45 - Peak 1 of 1																					
Peak Hour for Entire Intersection Begins at 16:30																					
16:30	11	506	110	0	627	44	47	2	0	93	3	503	19	0	525	93	63	6	0	162	1407
16:45	16	461	104	0	581	63	43	10	0	116	18	620	19	0	657	65	33	8	0	106	1460
17:00	8	472	91	0	571	53	30	8	0	91	10	631	11	0	652	63	44	14	0	121	1435
17:15	9	486	105	0	600	33	44	11	0	88	7	584	20	0	611	78	81	16	0	175	1474
Total Volume	44	1925	410	0	2379	193	164	31	0	388	38	2338	69	0	2445	299	221	44	0	564	5776
% App. Total	1.8	80.9	17.2	0		49.7	42.3	8	0		1.6	95.6	2.8	0		53	39.2	7.8	0		
PHF	.688	.951	.932	.000	.949	.766	.872	.705	.000	.836	.528	.926	.863	.000	.930	.804	.682	.688	.000	.806	.980

