

TRAFFIC DATA INC.

3268 Xenwood Ave S
St Louis Park, MN 55416

CSAH-17 / Marschall Rd at 17th Ave E
S of TH-169 SHAKOPEE
Data by TDI
TURN MOVEMENT COUNT

File Name : 10512024 CR 17 & 17th Ave
Site Code : 10512024
Start Date : 3/13/2012
Page No : 1

Groups Printed- Cars - Heavy Vehicles

Start Time	CSAH-17 / Marschall Rd Southbound				17th Ave E Westbound				CSAH-17 / Marschall Rd Northbound				17th Ave E Eastbound				Int. Total
	Left	Thru	Right	Bikes	Left	Thru	Right	Bikes	Left	Thru	Right	Bikes	Left	Thru	Right	Bikes	
06:00	12	16	9	0	4	6	17	0	4	62	1	0	43	12	3	0	189
06:15	34	16	10	0	1	6	31	0	9	90	2	0	93	15	7	0	314
06:30	35	40	12	0	1	12	40	0	22	109	4	0	87	29	9	0	400
06:45	26	50	24	0	1	24	63	0	15	104	6	0	78	23	21	0	435
Total	107	122	55	0	7	48	151	0	50	365	13	0	301	79	40	0	1338
07:00	25	47	18	0	7	24	55	0	33	110	8	0	95	34	14	0	470
07:15	42	55	19	0	8	61	74	0	39	132	9	0	103	45	17	0	604
07:30	57	68	27	0	13	59	65	0	40	156	21	0	116	45	31	0	698
07:45	63	104	26	1	5	52	53	0	44	140	7	0	95	45	29	0	664
Total	187	274	90	1	33	196	247	0	156	538	45	0	409	169	91	0	2436
08:00	54	55	25	1	8	76	53	1	47	117	16	1	84	47	22	0	607
08:15	49	69	26	0	5	45	75	0	31	110	19	0	93	51	23	0	596
08:30	42	59	16	1	6	29	47	1	27	102	14	0	75	38	15	0	472
08:45	34	64	25	1	6	49	50	2	18	96	10	0	56	51	15	0	477
Total	179	247	92	3	25	199	225	4	123	425	59	1	308	187	75	0	2152
09:00	45	49	22	0	10	40	50	1	19	72	13	0	41	24	5	0	391
09:15	42	61	21	0	6	16	34	0	19	80	14	0	50	15	9	0	367
09:30	41	45	25	0	8	18	33	1	18	82	9	0	47	24	16	0	367
09:45	34	57	13	0	10	18	57	0	21	72	11	0	48	24	13	0	378
Total	162	212	81	0	34	92	174	2	77	306	47	0	186	87	43	0	1503
10:00	41	56	15	0	8	26	68	1	14	86	5	0	37	22	11	0	390
10:15	44	52	27	0	11	23	34	1	9	58	13	0	47	21	10	0	350
10:30	48	40	24	0	9	19	63	0	15	75	19	0	36	24	7	0	379
10:45	45	80	21	2	9	23	40	0	13	67	10	0	27	22	8	0	367
Total	178	228	87	2	37	91	205	2	51	286	47	0	147	89	36	0	1486
11:00	50	63	25	0	11	35	59	0	3	59	9	0	30	29	10	0	383
11:15	52	58	15	0	7	39	63	0	24	66	18	0	26	38	6	0	412
11:30	57	54	43	0	13	21	52	3	18	72	17	0	31	44	17	0	442
11:45	77	56	35	0	10	35	65	3	15	70	14	1	32	38	20	0	471
Total	236	231	118	0	41	130	239	6	60	267	58	1	119	149	53	0	1708
12:00	68	61	36	2	14	35	64	2	21	76	12	0	38	36	11	0	476
12:15	77	55	38	0	14	36	84	0	14	79	18	0	38	44	18	0	515
12:30	77	61	28	2	16	41	87	3	16	65	13	0	37	39	19	0	504
12:45	66	98	26	0	8	34	77	1	11	66	9	0	26	38	19	0	479
Total	288	275	128	4	52	146	312	6	62	286	52	0	139	157	67	0	1974
13:00	72	59	23	0	8	45	68	2	19	63	8	0	61	22	16	0	466
13:15	74	82	31	0	17	24	67	0	14	63	13	0	40	22	12	0	459
13:30	62	55	33	0	20	33	91	3	5	81	16	0	33	28	23	0	483
13:45	57	59	27	4	19	18	88	2	5	80	18	2	27	35	14	0	455
Total	265	255	114	4	64	120	314	7	43	287	55	2	161	107	65	0	1863
14:00	85	84	18	5	20	31	76	0	22	105	8	0	45	28	9	0	536
14:15	76	87	34	0	15	40	70	0	11	74	15	1	52	34	28	0	537
14:30	76	96	24	0	16	30	69	0	16	83	16	1	33	31	20	1	512
14:45	85	118	39	0	18	50	69	0	21	89	15	1	28	42	18	0	593
Total	322	385	115	5	69	151	284	0	70	351	54	3	158	135	75	1	2178
15:00	58	90	47	0	18	38	123	1	35	75	10	0	71	82	32	0	680
15:15	94	122	72	0	16	61	93	0	17	97	18	1	45	76	36	0	748
15:30	122	142	60	0	32	76	99	0	20	91	33	2	59	102	34	0	872

TRAFFIC DATA INC.

3268 Xenwood Ave S
St Louis Park, MN 55416

CSAH-17 / Marshall Rd at 17th Ave E
S of TH-169 SHAKOPEE
Data by TDI
TURN MOVEMENT COUNT

File Name : 10512024 CR 17 & 17th Ave
Site Code : 10512024
Start Date : 3/13/2012
Page No : 3

Start Time	CSAH-17 / Marshall Rd Southbound					17th Ave E Westbound					CSAH-17 / Marshall Rd Northbound					17th Ave E Eastbound					Int. Total
	Left	Thru	Right	Bikes	App. Total	Left	Thru	Right	Bikes	App. Total	Left	Thru	Right	Bikes	App. Total	Left	Thru	Right	Bikes	App. Total	
Peak Hour Analysis From 06:00 to 09:45 - Peak 1 of 1																					
Peak Hour for Entire Intersection Begins at 07:15																					
07:15	42	55	19	0	116	8	61	74	0	143	39	132	9	0	180	103	45	17	0	165	604
07:30	57	68	27	0	152	13	59	65	0	137	40	156	21	0	217	116	45	31	0	192	698
07:45	63	104	26	1	194	5	52	53	0	110	44	140	7	0	191	95	45	29	0	169	664
08:00	54	55	25	1	135	8	76	53	1	138	47	117	16	1	181	84	47	22	0	153	607
Total Volume	216	282	97	2	597	34	248	245	1	528	170	545	53	1	769	398	182	99	0	679	2573
% App. Total	36.2	47.2	16.2	0.3		6.4	47	46.4	0.2		22.1	70.9	6.9	0.1		58.6	26.8	14.6	0		
PHF	.857	.678	.898	.500	.769	.654	.816	.828	.250	.923	.904	.873	.631	.250	.886	.858	.968	.798	.000	.884	.922

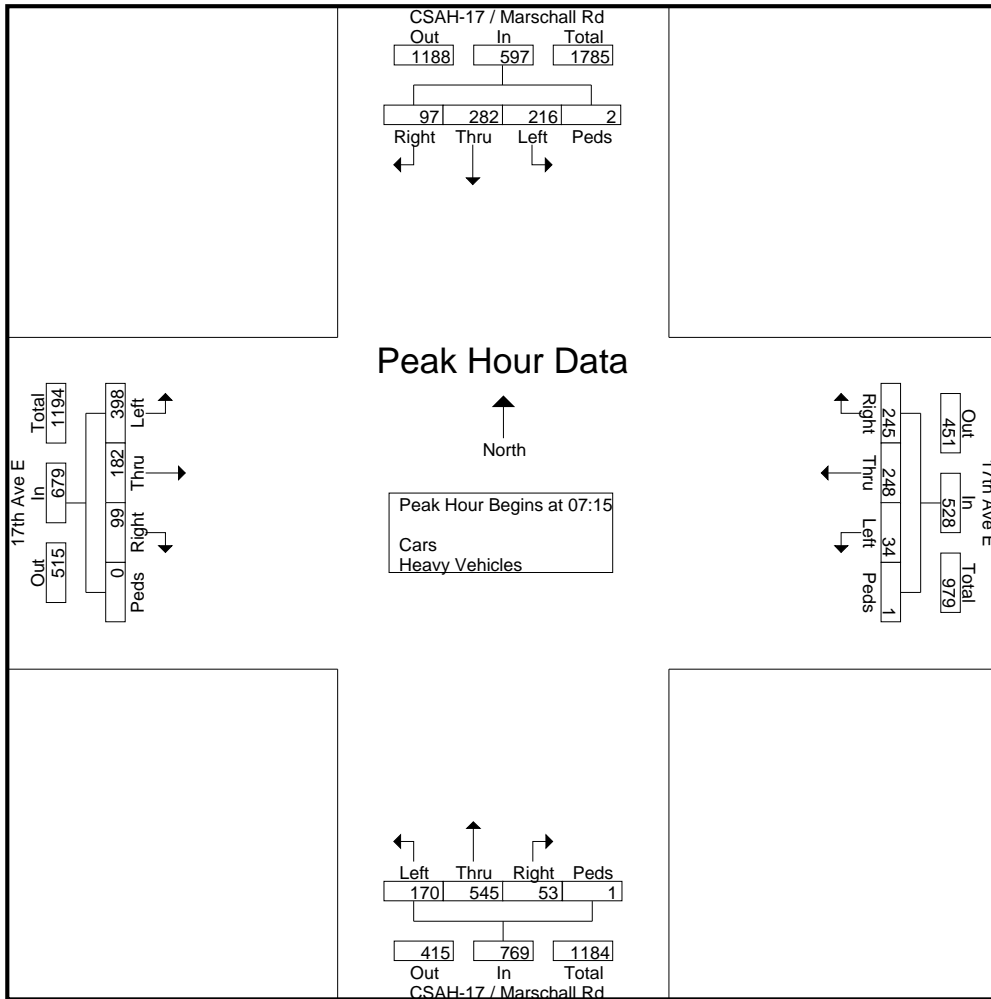

TRAFFIC DATA INC.

3268 Xenwood Ave S
St Louis Park, MN 55416

CSAH-17 / Marschall Rd at 17th Ave E
S of TH-169 SHAKOPEE
Data by TDI
TURN MOVEMENT COUNT

File Name : 10512024 CR 17 & 17th Ave
Site Code : 10512024
Start Date : 3/13/2012
Page No : 4

Start Time	CSAH-17 / Marschall Rd Southbound					17th Ave E Westbound					CSAH-17 / Marschall Rd Northbound					17th Ave E Eastbound					Int. Total
	Left	Thru	Right	Bikes	App. Total	Left	Thru	Right	Bikes	App. Total	Left	Thru	Right	Bikes	App. Total	Left	Thru	Right	Bikes	App. Total	
Peak Hour Analysis From 10:00 to 13:45 - Peak 1 of 1																					
Peak Hour for Entire Intersection Begins at 12:00																					
12:00	68	61	36	2	167	14	35	64	2	115	21	76	12	0	109	38	36	11	0	85	476
12:15	77	55	38	0	170	14	36	84	0	134	14	79	18	0	111	38	44	18	0	100	515
12:30	77	61	28	2	168	16	41	87	3	147	16	65	13	0	94	37	39	19	0	95	504
12:45	66	98	26	0	190	8	34	77	1	120	11	66	9	0	86	26	38	19	0	83	479
Total Volume	288	275	128	4	695	52	146	312	6	516	62	286	52	0	400	139	157	67	0	363	1974
% App. Total	41.4	39.6	18.4	0.6		10.1	28.3	60.5	1.2		15.5	71.5	13	0		38.3	43.3	18.5	0		
PHF	.935	.702	.842	.500	.914	.813	.890	.897	.500	.878	.738	.905	.722	.000	.901	.914	.892	.882	.000	.908	.958

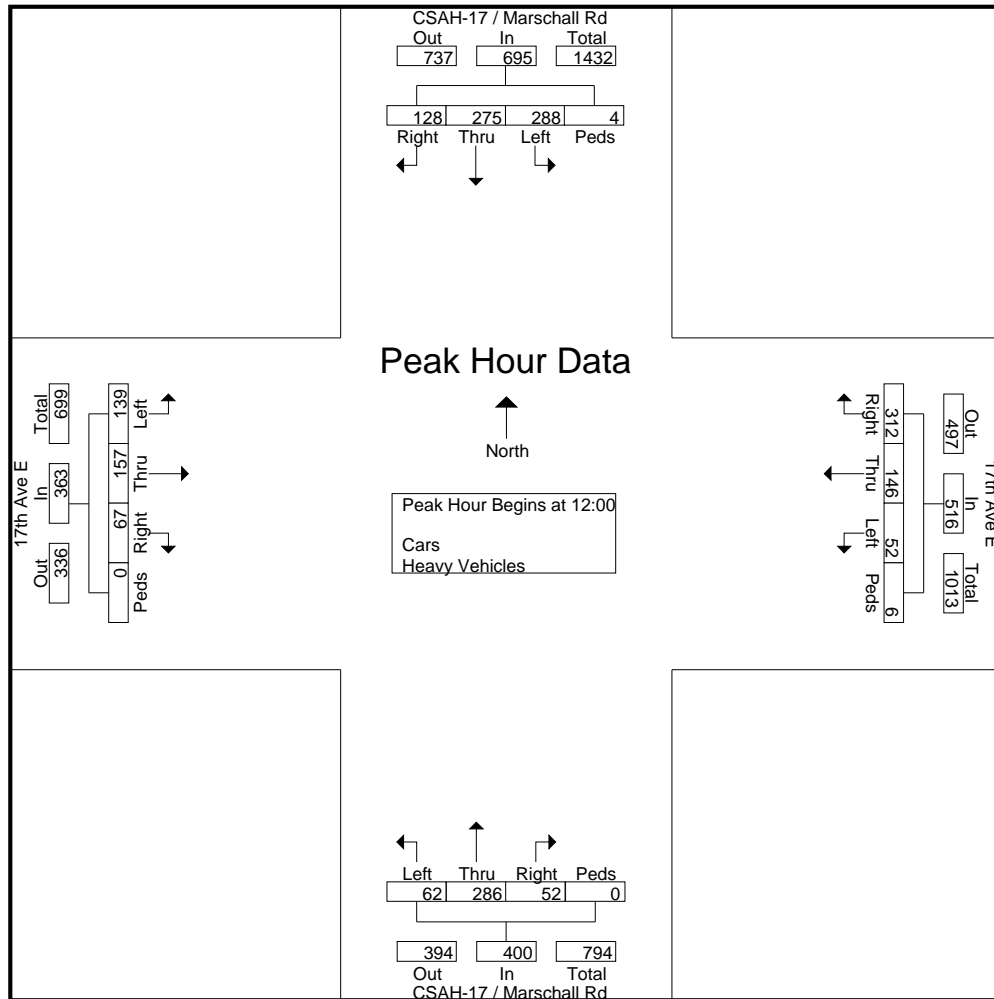

TRAFFIC DATA INC.

3268 Xenwood Ave S
St Louis Park, MN 55416

CSAH-17 / Marschall Rd at 17th Ave E
S of TH-169 SHAKOPEE
Data by TDI
TURN MOVEMENT COUNT

File Name : 10512024 CR 17 & 17th Ave
Site Code : 10512024
Start Date : 3/13/2012
Page No : 5

Start Time	CSAH-17 / Marschall Rd Southbound					17th Ave E Westbound					CSAH-17 / Marschall Rd Northbound					17th Ave E Eastbound					Int. Total
	Left	Thru	Right	Bikes	App. Total	Left	Thru	Right	Bikes	App. Total	Left	Thru	Right	Bikes	App. Total	Left	Thru	Right	Bikes	App. Total	
Peak Hour Analysis From 14:00 to 18:45 - Peak 1 of 1																					
Peak Hour for Entire Intersection Begins at 16:30																					
16:30	104	136	100	2	342	28	75	92	0	195	41	124	19	1	185	70	71	43	0	184	906
16:45	157	144	73	4	378	15	81	66	1	163	28	92	26	4	150	71	85	32	0	188	879
17:00	191	144	91	2	428	29	111	92	0	232	42	97	22	0	161	53	67	25	0	145	966
17:15	170	139	91	0	400	29	93	80	1	203	53	107	8	2	170	65	71	20	0	156	929
Total Volume	622	563	355	8	1548	101	360	330	2	793	164	420	75	7	666	259	294	120	0	673	3680
% App. Total	40.2	36.4	22.9	0.5		12.7	45.4	41.6	0.3		24.6	63.1	11.3	1.1		38.5	43.7	17.8	0		
PHF	.814	.977	.888	.500	.904	.871	.811	.897	.500	.855	.774	.847	.721	.438	.900	.912	.865	.698	.000	.895	.952

