

Alliant Engineering, Inc

233 Park Ave Suite 300
 Minneapolis, MN 55415

--TRAFFIC DATA --

CSAH-17 at TH-169 North Ramp
 Ref.Pt.: 110.743
 data by : Alliant Inc.
 TURN MOVEMENT COUNT

File Name : 333_CSAH 17 & TH 169 N Ramp
 Site Code : 333
 Start Date : 11/8/2017
 Page No : 1

Groups Printed- Vehicles - Trucks

Start Time	CSAH 17 From North				TH 169 N Ramp From East				CSAH 17 From South				TH 169 N Ramp From West				Int. Total
	Other	Left	Thru	Rght	Other	Left	Thru	Rght	Other	Left	Thru	Rght	Other	Left	Thru	Rght	
06:00 AM	0	0	78	16	0	34	0	15	0	14	48	0	0	0	0	0	205
06:15 AM	0	0	95	28	0	26	0	27	0	18	58	0	0	0	0	0	252
06:30 AM	0	0	110	25	0	43	0	42	0	15	72	0	0	0	0	0	307
06:45 AM	0	0	120	25	0	48	2	83	0	19	118	0	0	0	0	0	415
Total	0	0	403	94	0	151	2	167	0	66	296	0	0	0	0	0	1179
07:00 AM	0	0	164	13	0	33	1	77	0	17	130	0	0	0	0	0	435
07:15 AM	0	0	136	26	0	49	0	71	0	24	169	0	0	0	0	0	475
07:30 AM	0	0	167	37	0	45	0	82	0	27	172	0	0	0	0	0	530
07:45 AM	0	0	134	22	0	56	1	58	0	34	122	0	0	0	0	0	427
Total	0	0	601	98	0	183	2	288	0	102	593	0	0	0	0	0	1867
08:00 AM	0	0	123	16	0	64	1	59	1	12	114	0	0	0	0	0	390
08:15 AM	0	0	129	21	0	29	0	53	0	26	131	0	0	0	0	0	389
08:30 AM	0	0	138	16	0	30	0	55	0	17	89	0	0	0	0	0	345
08:45 AM	0	0	119	13	0	47	0	52	0	25	113	0	0	0	0	0	369
Total	0	0	509	66	0	170	1	219	1	80	447	0	0	0	0	0	1493
09:00 AM	0	0	126	19	0	35	0	36	0	27	99	0	0	0	0	0	342
09:15 AM	0	0	117	18	0	36	0	41	0	18	93	0	0	0	0	0	323
*** BREAK ***																	
Total	0	0	243	37	0	71	0	77	0	45	192	0	0	0	0	0	665
*** BREAK ***																	
10:30 AM	0	0	104	19	0	55	0	44	0	13	93	0	0	0	0	0	328
10:45 AM	0	0	120	16	0	48	1	49	0	16	110	0	0	0	0	0	360
Total	0	0	224	35	0	103	1	93	0	29	203	0	0	0	0	0	688
11:00 AM	0	0	115	22	0	58	0	45	0	10	100	0	0	0	0	0	350
11:15 AM	0	0	126	20	0	49	0	59	0	16	100	0	0	0	0	0	370
11:30 AM	0	0	135	29	0	54	1	57	0	24	125	0	0	0	0	0	425
11:45 AM	0	0	130	33	0	49	0	69	0	19	140	0	0	0	0	0	440
Total	0	0	506	104	0	210	1	230	0	69	465	0	0	0	0	0	1585
12:00 PM	1	0	147	31	0	60	1	44	0	16	125	0	0	0	0	0	425
12:15 PM	0	0	165	30	0	59	1	97	0	26	124	0	0	0	0	0	502
12:30 PM	0	0	161	28	0	53	0	64	0	18	119	0	0	0	0	0	443
12:45 PM	0	0	154	32	0	71	0	63	0	15	106	0	0	0	0	0	441
Total	1	0	627	121	0	243	2	268	0	75	474	0	0	0	0	0	1811
01:00 PM	0	0	164	32	0	52	0	62	0	22	117	0	0	0	0	0	449
01:15 PM	0	0	150	37	0	50	0	61	0	34	108	0	0	0	0	0	440
*** BREAK ***																	
Total	0	0	314	69	0	102	0	123	0	56	225	0	0	0	0	0	889
*** BREAK ***																	
02:30 PM	0	0	183	28	0	91	0	85	0	24	121	0	0	0	0	0	532
02:45 PM	0	0	192	39	0	81	0	78	0	32	102	0	0	0	0	0	524
Total	0	0	375	67	0	172	0	163	0	56	223	0	0	0	0	0	1056
03:00 PM	1	0	167	36	0	98	0	87	0	28	131	0	0	0	0	0	548
03:15 PM	0	0	200	31	0	79	0	82	0	37	156	0	0	0	0	0	585
03:30 PM	0	0	207	40	0	107	0	99	0	45	178	0	0	0	0	0	676
03:45 PM	0	0	228	41	0	103	0	120	0	40	158	0	0	0	0	0	690
Total	1	0	802	148	0	387	0	388	0	150	623	0	0	0	0	0	2499
04:00 PM	0	0	233	41	0	90	0	114	0	45	149	0	0	0	0	0	672
04:15 PM	0	0	211	41	0	103	0	136	0	27	152	0	0	0	0	0	670
04:30 PM	0	0	212	46	0	154	0	119	0	37	130	0	0	0	0	0	698
04:45 PM	0	0	226	44	0	106	0	119	0	53	187	0	0	0	0	0	735
Total	0	0	882	172	0	453	0	488	0	162	618	0	0	0	0	0	2775

Alliant Engineering, Inc

233 Park Ave Suite 300
 Minneapolis, MN 55415

--TRAFFIC DATA --

CSAH-17 at TH-169 North Ramp
 Ref.Pt.: 110.743
 data by : Alliant Inc.
 TURN MOVEMENT COUNT

File Name : 333_CSAH 17 & TH 169 N Ramp
 Site Code : 333
 Start Date : 11/8/2017
 Page No : 2

Groups Printed- Vehicles - Trucks

Start Time	CSAH 17 From North				TH 169 N Ramp From East				CSAH 17 From South				TH 169 N Ramp From West				Int. Total
	Other	Left	Thru	Rght	Other	Left	Thru	Rght	Other	Left	Thru	Rght	Other	Left	Thru	Rght	
05:00 PM	0	0	202	68	0	106	0	108	0	37	158	0	0	0	0	0	679
05:15 PM	0	0	215	39	0	100	0	117	0	26	163	0	0	0	0	0	660
05:30 PM	0	0	200	37	0	108	0	85	0	24	138	0	0	0	0	0	592
05:45 PM	0	0	175	48	0	127	0	130	0	22	162	0	0	0	0	0	664
Total	0	0	792	192	0	441	0	440	0	109	621	0	0	0	0	0	2595
Grand Total	2	0	6278	1203	0	2686	9	2944	1	999	4980	0	0	0	0	0	19102
Apprch %	0	0	83.9	16.1	0	47.6	0.2	52.2	0	16.7	83.3	0	0	0	0	0	
Total %	0	0	32.9	6.3	0	14.1	0	15.4	0	5.2	26.1	0	0	0	0	0	
Vehicles	2	0	6080	1167	0	2530	8	2869	0	963	4795	0	0	0	0	0	18414
% Vehicles	100	0	96.8	97	0	94.2	88.9	97.5	0	96.4	96.3	0	0	0	0	0	96.4
Trucks	0	0	198	36	0	156	1	75	1	36	185	0	0	0	0	0	688
% Trucks	0	0	3.2	3	0	5.8	11.1	2.5	100	3.6	3.7	0	0	0	0	0	3.6

Alliant Engineering, Inc

233 Park Ave Suite 300
 Minneapolis, MN 55415

--TRAFFIC DATA --

CSAH-17 at TH-169 North Ramp
 Ref.Pt.: 110.743
 data by : Alliant Inc.
 TURN MOVEMENT COUNT

File Name : 333_CSAH 17 & TH 169 N Ramp
 Site Code : 333
 Start Date : 11/8/2017
 Page No : 3

Start Time	CSAH 17 From North					TH 169 N Ramp From East					CSAH 17 From South					TH 169 N Ramp From West					Int. Total
	Other	Left	Thru	Rght	App. Total	Other	Left	Thru	Rght	App. Total	Other	Left	Thru	Rght	App. Total	Other	Left	Thru	Rght	App. Total	
Peak Hour Analysis From 06:00 AM to 11:45 AM - Peak 1 of 1																					
Peak Hour for Entire Intersection Begins at 07:00 AM																					
07:00 AM	0	0	164	13	177	0	33	1	77	111	0	17	130	0	147	0	0	0	0	0	435
07:15 AM	0	0	136	26	162	0	49	0	71	120	0	24	169	0	193	0	0	0	0	0	475
07:30 AM	0	0	167	37	204	0	45	0	82	127	0	27	172	0	199	0	0	0	0	0	530
07:45 AM	0	0	134	22	156	0	56	1	58	115	0	34	122	0	156	0	0	0	0	0	427
Total Volume	0	0	601	98	699	0	183	2	288	473	0	102	593	0	695	0	0	0	0	0	1867
% App. Total	0	0	86	14		0	38.7	0.4	60.9		0	14.7	85.3	0		0	0	0	0		
PHF	.000	.000	.900	.662	.857	.000	.817	.500	.878	.931	.000	.750	.862	.000	.873	.000	.000	.000	.000	.000	.881

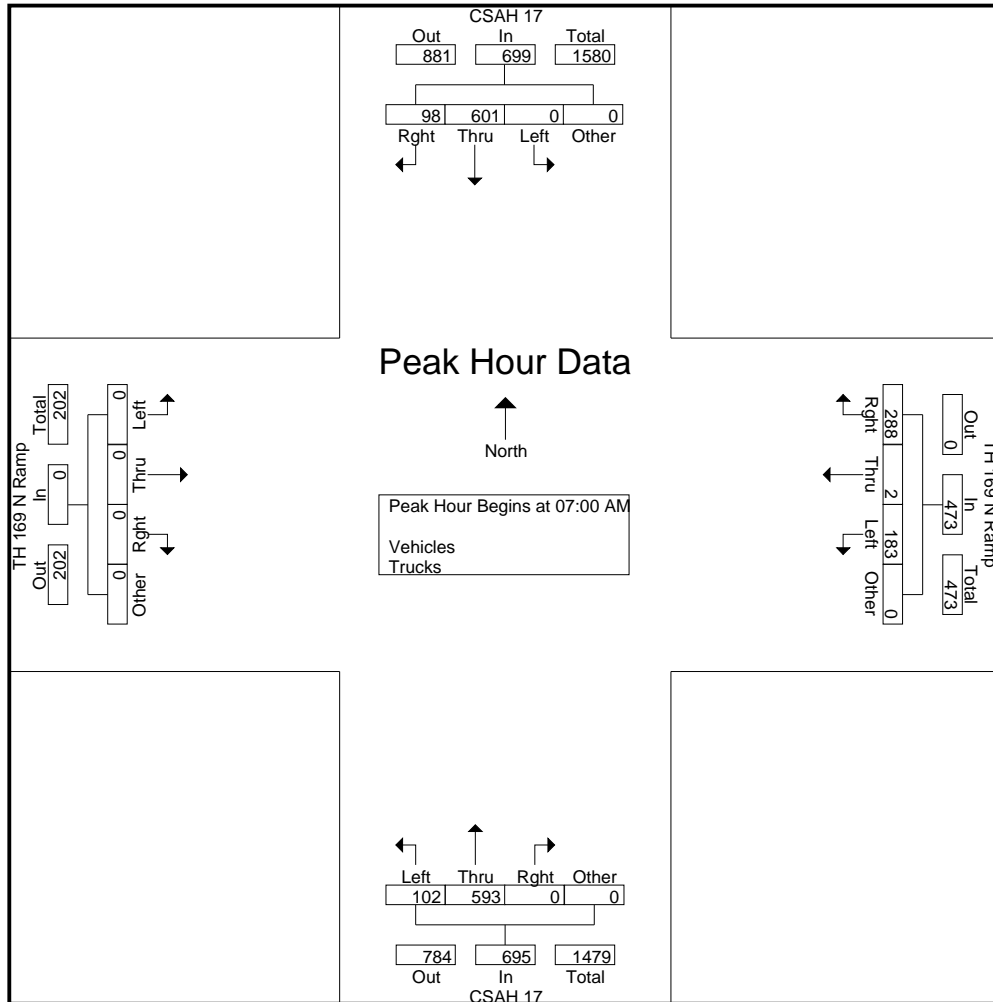

Alliant Engineering, Inc

233 Park Ave Suite 300
 Minneapolis, MN 55415

--TRAFFIC DATA --

CSAH-17 at TH-169 North Ramp
 Ref.Pt.: 110.743
 data by : Alliant Inc.
 TURN MOVEMENT COUNT

File Name : 333_CSAH 17 & TH 169 N Ramp
 Site Code : 333
 Start Date : 11/8/2017
 Page No : 4

Start Time	CSAH 17 From North					TH 169 N Ramp From East					CSAH 17 From South					TH 169 N Ramp From West					Int. Total
	Other	Left	Thru	Rght	App. Total	Other	Left	Thru	Rght	App. Total	Other	Left	Thru	Rght	App. Total	Other	Left	Thru	Rght	App. Total	
Peak Hour Analysis From 12:00 PM to 05:45 PM - Peak 1 of 1																					
Peak Hour for Entire Intersection Begins at 04:15 PM																					
04:15 PM	0	0	211	41	252	0	103	0	136	239	0	27	152	0	179	0	0	0	0	0	670
04:30 PM	0	0	212	46	258	0	154	0	119	273	0	37	130	0	167	0	0	0	0	0	698
04:45 PM	0	0	226	44	270	0	106	0	119	225	0	53	187	0	240	0	0	0	0	0	735
05:00 PM	0	0	202	68	270	0	106	0	108	214	0	37	158	0	195	0	0	0	0	0	679
Total Volume	0	0	851	199	1050	0	469	0	482	951	0	154	627	0	781	0	0	0	0	0	2782
% App. Total	0	0	81	19		0	49.3	0	50.7		0	19.7	80.3	0		0	0	0	0	0	
PHF	.000	.000	.941	.732	.972	.000	.761	.000	.886	.871	.000	.726	.838	.000	.814	.000	.000	.000	.000	.000	.946

