

**Alliant Engineering, Inc**

233 Park Ave Suite 300  
 Minneapolis, MN 55415

--TRAFFIC DATA --

CSAH-17 at TH-169 South Ramp

Ref.Pt.: 110.742

data by : Alliant Inc.

TURN MOVEMENT COUNT

File Name : 332\_CSAH 17 & TH 169 S Ramp

Site Code : 332

Start Date : 11/8/2017

Page No : 1

Groups Printed- Vehicles - Trucks

Start Time	CSAH 17 From North				TH 169 S Ramp From East				CSAH 17 From South				TH 169 S Ramp From West				Int. Total
	Other	Left	Thru	Rght	Other	Left	Thru	Rght	Other	Left	Thru	Rght	Other	Left	Thru	Rght	
06:00 AM	0	48	62	0	0	0	0	0	0	0	41	94	0	15	0	10	270
06:15 AM	0	70	65	0	0	0	0	0	0	0	53	122	0	13	0	23	346
06:30 AM	0	70	80	0	0	0	0	0	0	0	84	135	0	9	2	36	416
06:45 AM	1	66	102	0	0	0	0	0	0	0	129	170	0	20	3	37	528
Total	1	254	309	0	0	0	0	0	0	0	307	521	0	57	5	106	1560
07:00 AM	0	89	93	0	0	0	0	0	0	0	142	168	0	23	2	33	550
07:15 AM	0	78	139	0	0	0	0	0	0	0	164	129	0	19	3	25	557
07:30 AM	0	72	148	0	0	0	0	0	0	0	203	102	0	32	0	28	585
07:45 AM	0	70	140	0	0	0	0	0	0	0	161	121	0	19	1	51	563
Total	0	309	520	0	0	0	0	0	0	0	670	520	0	93	6	137	2255
08:00 AM	0	56	131	0	0	0	0	0	0	0	122	125	0	23	0	27	484
08:15 AM	0	61	104	0	0	0	0	0	0	0	138	84	0	27	1	32	447
08:30 AM	0	66	115	0	0	0	0	0	0	0	118	107	0	10	2	26	444
08:45 AM	0	61	108	0	0	0	0	0	0	0	127	83	0	29	0	36	444
Total	0	244	458	0	0	0	0	0	0	0	505	399	0	89	3	121	1819
09:00 AM	0	55	121	0	0	0	0	0	0	0	107	79	0	19	0	34	415
09:15 AM	0	48	98	0	0	0	0	0	0	0	114	69	0	24	1	18	372
*** BREAK ***																	
Total	0	103	219	0	0	0	0	0	0	0	221	148	0	43	1	52	787
*** BREAK ***																	
10:30 AM	0	58	111	0	0	0	0	0	0	0	102	55	0	10	1	19	356
10:45 AM	0	49	124	0	0	0	0	0	0	0	105	65	0	19	0	17	379
Total	0	107	235	0	0	0	0	0	0	0	207	120	0	29	1	36	735
11:00 AM	0	50	116	0	0	0	0	0	0	0	100	61	0	19	0	22	368
11:15 AM	1	49	137	0	0	0	0	0	0	0	111	52	0	15	0	23	388
11:30 AM	0	46	146	0	0	0	0	0	0	0	126	53	0	21	0	26	418
11:45 AM	0	54	141	0	0	0	0	0	0	0	144	63	0	25	2	19	448
Total	1	199	540	0	0	0	0	0	0	0	481	229	0	80	2	90	1622
12:00 PM	0	59	151	0	0	0	0	0	0	0	133	53	0	20	0	10	426
12:15 PM	0	61	168	0	0	0	0	0	1	0	119	50	0	29	0	12	440
12:30 PM	0	65	158	0	0	0	0	0	1	0	138	60	0	14	0	15	451
12:45 PM	0	61	163	0	0	0	0	0	0	0	106	63	0	25	1	17	436
Total	0	246	640	0	0	0	0	0	2	0	496	226	0	88	1	54	1753
01:00 PM	1	67	161	0	0	0	0	0	0	0	115	36	0	13	0	17	410
01:15 PM	0	62	144	0	0	0	0	0	0	0	101	64	0	25	0	20	416
*** BREAK ***																	
Total	1	129	305	0	0	0	0	0	0	0	216	100	0	38	0	37	826
*** BREAK ***																	
02:30 PM	0	44	144	0	0	0	0	0	0	0	129	57	0	23	0	23	420
02:45 PM	0	58	235	0	0	0	0	0	0	0	115	65	0	25	1	32	531
Total	0	102	379	0	0	0	0	0	0	0	244	122	0	48	1	55	951
03:00 PM	0	62	221	0	0	0	0	0	0	0	146	59	0	19	0	20	527
03:15 PM	1	59	234	0	0	0	0	0	0	0	172	66	0	24	2	30	588
03:30 PM	1	71	223	0	0	0	0	0	0	0	190	51	0	24	1	25	586
03:45 PM	0	67	275	0	0	0	0	0	0	0	170	47	0	24	0	22	605
Total	2	259	953	0	0	0	0	0	0	0	678	223	0	91	3	97	2306
04:00 PM	1	76	265	0	0	0	0	0	0	0	151	73	0	23	0	23	612
04:15 PM	0	65	274	0	0	0	0	0	0	0	158	48	0	30	1	28	604
04:30 PM	0	51	405	0	0	0	0	0	0	0	153	70	0	40	1	15	735
04:45 PM	1	51	301	0	0	0	0	0	0	0	202	76	0	55	3	33	722
Total	2	243	1245	0	0	0	0	0	0	0	664	267	0	148	5	99	2673

**Alliant Engineering, Inc**

233 Park Ave Suite 300

Minneapolis, MN 55415

--TRAFFIC DATA --

CSAH-17 at TH-169 South Ramp

Ref.Pt.: 110.742

data by : Alliant Inc.

TURN MOVEMENT COUNT

File Name : 332\_CSAH 17 & TH 169 S Ramp

Site Code : 332

Start Date : 11/8/2017

Page No : 2

Groups Printed- Vehicles - Trucks

Start Time	CSAH 17 From North				TH 169 S Ramp From East				CSAH 17 From South				TH 169 S Ramp From West				Int. Total
	Other	Left	Thru	Rght	Other	Left	Thru	Rght	Other	Left	Thru	Rght	Other	Left	Thru	Rght	
05:00 PM	0	58	293	0	0	0	0	0	0	0	183	55	0	29	0	21	639
05:15 PM	0	54	291	0	0	0	0	0	0	0	176	90	0	50	1	22	684
05:30 PM	0	56	269	0	0	0	0	0	0	0	164	68	0	20	0	13	590
05:45 PM	2	45	247	0	0	0	0	0	0	0	178	55	0	32	1	15	575
Total	2	213	1100	0	0	0	0	0	0	0	701	268	0	131	2	71	2488
Grand Total	9	2408	6903	0	0	0	0	0	2	0	5390	3143	0	935	30	955	19775
Apprch %	0.1	25.8	74.1	0	0	0	0	0	0	0	63.2	36.8	0	48.7	1.6	49.7	
Total %	0	12.2	34.9	0	0	0	0	0	0	0	27.3	15.9	0	4.7	0.2	4.8	
Vehicles	9	2340	6637	0	0	0	0	0	2	0	5235	3024	0	903	29	922	19101
% Vehicles	100	97.2	96.1	0	0	0	0	0	100	0	97.1	96.2	0	96.6	96.7	96.5	96.6
Trucks	0	68	266	0	0	0	0	0	0	0	155	119	0	32	1	33	674
% Trucks	0	2.8	3.9	0	0	0	0	0	0	0	2.9	3.8	0	3.4	3.3	3.5	3.4

**Alliant Engineering, Inc**

233 Park Ave Suite 300  
 Minneapolis, MN 55415

--TRAFFIC DATA --

CSAH-17 at TH-169 South Ramp  
 Ref.Pt.: 110.742  
 data by : Alliant Inc.  
 TURN MOVEMENT COUNT

File Name : 332\_CSAH 17 & TH 169 S Ramp  
 Site Code : 332  
 Start Date : 11/8/2017  
 Page No : 3

Start Time	CSAH 17 From North					TH 169 S Ramp From East					CSAH 17 From South					TH 169 S Ramp From West					Int. Total
	Other	Left	Thru	Rght	App. Total	Other	Left	Thru	Rght	App. Total	Other	Left	Thru	Rght	App. Total	Other	Left	Thru	Rght	App. Total	
Peak Hour Analysis From 06:00 AM to 11:45 AM - Peak 1 of 1																					
Peak Hour for Entire Intersection Begins at 07:00 AM																					
07:00 AM	0	89	93	0	182	0	0	0	0	0	0	0	142	168	310	0	23	2	33	58	550
07:15 AM	0	78	139	0	217	0	0	0	0	0	0	0	164	129	293	0	19	3	25	47	557
07:30 AM	0	72	148	0	220	0	0	0	0	0	0	0	203	102	305	0	32	0	28	60	585
07:45 AM	0	70	140	0	210	0	0	0	0	0	0	0	161	121	282	0	19	1	51	71	563
Total Volume	0	309	520	0	829	0	0	0	0	0	0	0	670	520	1190	0	93	6	137	236	2255
% App. Total	0	37.3	62.7	0		0	0	0	0	0	0	0	56.3	43.7		0	39.4	2.5	58.1		
PHF	.000	.868	.878	.000	.942	.000	.000	.000	.000	.000	.000	.000	.825	.774	.960	.000	.727	.500	.672	.831	.964

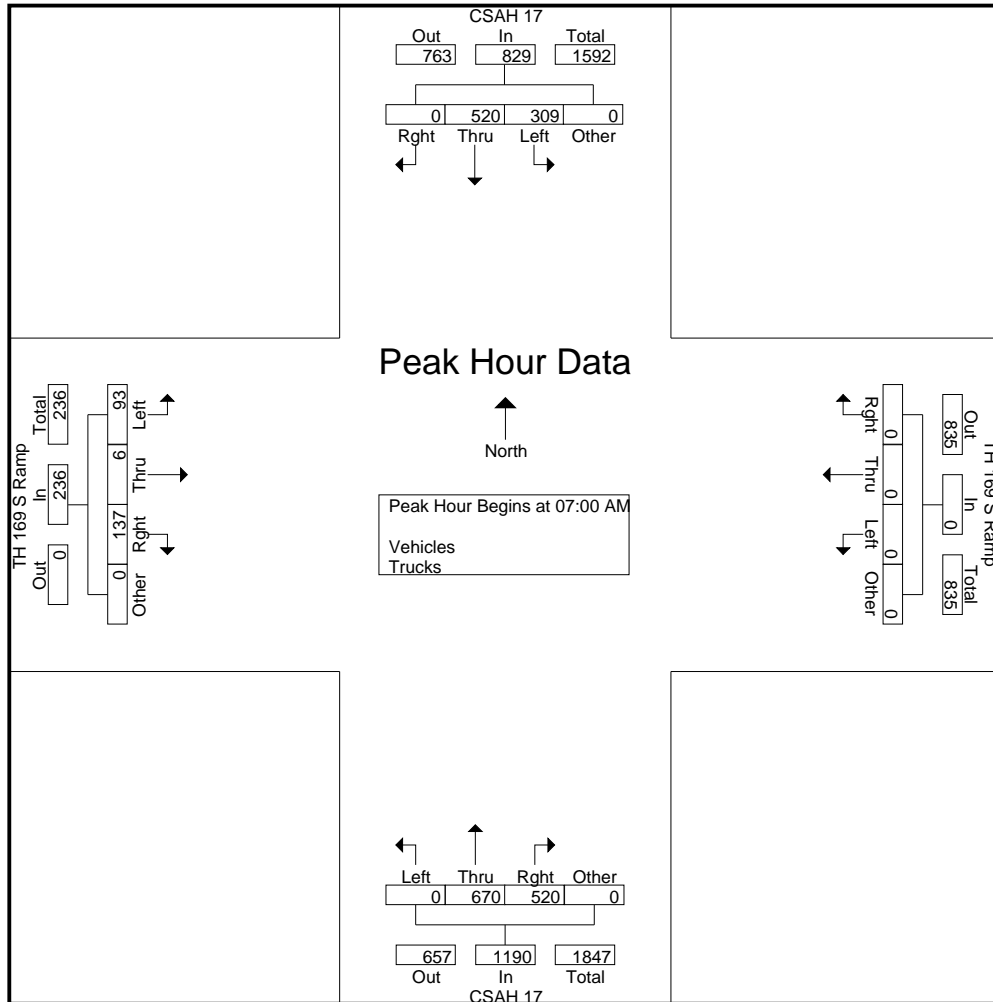

**Alliant Engineering, Inc**

233 Park Ave Suite 300  
 Minneapolis, MN 55415

--TRAFFIC DATA --

CSAH-17 at TH-169 South Ramp  
 Ref.Pt.: 110.742  
 data by : Alliant Inc.  
 TURN MOVEMENT COUNT

File Name : 332\_CSAH 17 & TH 169 S Ramp  
 Site Code : 332  
 Start Date : 11/8/2017  
 Page No : 4

Start Time	CSAH 17 From North					TH 169 S Ramp From East					CSAH 17 From South					TH 169 S Ramp From West					Int. Total
	Other	Left	Thru	Rght	App. Total	Other	Left	Thru	Rght	App. Total	Other	Left	Thru	Rght	App. Total	Other	Left	Thru	Rght	App. Total	
Peak Hour Analysis From 12:00 PM to 05:45 PM - Peak 1 of 1																					
Peak Hour for Entire Intersection Begins at 04:30 PM																					
04:30 PM	0	51	405	0	456	0	0	0	0	0	0	0	153	70	223	0	40	1	15	56	735
04:45 PM	1	51	301	0	353	0	0	0	0	0	0	0	202	76	278	0	55	3	33	91	722
05:00 PM	0	58	293	0	351	0	0	0	0	0	0	0	183	55	238	0	29	0	21	50	639
05:15 PM	0	54	291	0	345	0	0	0	0	0	0	0	176	90	266	0	50	1	22	73	684
Total Volume	1	214	1290	0	1505	0	0	0	0	0	0	0	714	291	1005	0	174	5	91	270	2780
% App. Total	0.1	14.2	85.7	0		0	0	0	0	0	0	0	71	29		0	64.4	1.9	33.7		
PHF	.250	.922	.796	.000	.825	.000	.000	.000	.000	.000	.000	.000	.884	.808	.904	.000	.791	.417	.689	.742	.946

