



# MINNESOTA DEPT OF TRANSPORTATION

## TRAFFIC DATA COLLECTION - METRO

TH-169 at Mobile Manor entrance  
 Ref.Pt.: 107.030  
 Jx  
 JAMAR # T2582  
 TURN MOVEMENT COUNT

File Name : TH-169 at Mobile Manor 2012  
 Site Code : 00000001  
 Start Date : 6/6/2012  
 Page No : 1

### Groups Printed- Cars & Trucks

Start Time	TH-169 Southbound				Mobile Manor entrance Westbound				TH-169 Northbound				business entrance Eastbound				Int. Total	
	Left	Thru	Right	Peds	Left	Thru	Right	Peds	Left	Thru	Right	Peds	Left	Thru	Right	Peds		
06:00	1	95	0	0	1	0	3	0	0	259	0	0	0	0	0	0	0	359
06:15	1	168	1	1	0	0	1	1	1	337	0	0	0	0	0	0	0	511
06:30	0	188	4	1	0	0	6	0	0	406	1	1	0	0	0	0	0	607
06:45	3	191	8	0	4	1	1	0	2	388	2	0	1	0	0	0	0	601
Total	5	642	13	2	5	1	11	1	3	1390	3	1	1	0	0	0	0	2078
07:00	1	225	0	0	2	0	5	0	0	372	1	0	1	0	1	0	0	608
07:15	3	200	2	0	2	0	2	1	0	378	1	0	1	0	2	0	0	592
07:30	1	238	0	0	1	0	2	0	0	428	0	0	0	0	2	0	0	672
07:45	1	222	1	0	0	0	6	0	0	392	1	0	0	0	1	0	0	624
Total	6	885	3	0	5	0	15	1	0	1570	3	0	2	0	6	0	0	2496
08:00	1	201	0	0	0	0	3	0	0	364	1	0	0	0	2	0	0	572
08:15	0	191	0	0	0	0	2	0	0	298	0	0	0	0	0	0	0	491
08:30	0	207	0	0	1	0	0	0	0	312	1	0	0	0	0	0	0	521
08:45	0	207	0	0	0	0	1	0	0	246	0	0	0	0	1	0	0	455
Total	1	806	0	0	1	0	6	0	0	1220	2	0	0	0	3	0	0	2039
*** BREAK ***																		
15:00	0	328	1	0	0	0	1	0	0	278	0	0	0	0	1	0	0	609
15:15	5	359	0	0	1	0	1	0	0	240	1	0	0	0	0	0	0	607
15:30	2	387	1	1	2	0	7	0	0	242	13	0	1	0	0	0	0	656
15:45	2	370	0	0	0	0	1	0	0	276	3	0	0	0	0	0	0	652
Total	9	1444	2	1	3	0	10	0	0	1036	17	0	1	0	1	0	0	2524
16:00	3	394	1	0	1	0	1	0	1	246	0	0	1	0	0	0	0	648
16:15	4	443	0	0	2	0	3	0	0	244	0	0	0	0	1	0	0	697
16:30	4	446	0	0	0	0	0	0	1	246	1	0	2	0	0	0	0	700
16:45	3	461	1	0	2	0	3	0	0	260	4	0	2	0	0	0	0	736
Total	14	1744	2	0	5	0	7	0	2	996	5	0	5	0	1	0	0	2781
17:00	2	428	1	1	1	0	3	0	0	251	5	0	1	0	1	1	0	695
17:15	6	432	0	0	1	0	1	0	0	281	4	0	4	0	2	0	0	731
17:30	2	364	0	0	3	0	5	0	0	270	1	1	0	0	1	0	0	647
17:45	6	345	0	0	0	0	5	0	0	235	0	0	0	0	0	0	0	591
Total	16	1569	1	1	5	0	14	0	0	1037	10	1	5	0	4	1	0	2664
Grand Total	51	7090	21	4	24	1	63	2	5	7249	40	2	14	0	15	1	0	14582
Apprch %	0.7	98.9	0.3	0.1	26.7	1.1	70	2.2	0.1	99.4	0.5	0	46.7	0	50	3.3	0	
Total %	0.3	48.6	0.1	0	0.2	0	0.4	0	0	49.7	0.3	0	0.1	0	0.1	0	0	



# MINNESOTA DEPT OF TRANSPORTATION

## TRAFFIC DATA COLLECTION - METRO

TH-169 at Mobile Manor entrance  
 Ref.Pt.: 107.030  
 Jx  
 JAMAR # T2582  
 TURN MOVEMENT COUNT

File Name : TH-169 at Mobile Manor 2012  
 Site Code : 00000001  
 Start Date : 6/6/2012  
 Page No : 2

Start Time	TH-169 Southbound					Mobile Manor entrance Westbound					TH-169 Northbound					business entrance Eastbound					Int. Total
	Left	Thru	Right	Peds	App. Total	Left	Thru	Right	Peds	App. Total	Left	Thru	Right	Peds	App. Total	Left	Thru	Right	Peds	App. Total	
Peak Hour Analysis From 06:00 to 08:45 - Peak 1 of 1																					
Peak Hour for Entire Intersection Begins at 07:00																					
07:00	1	225	0	0	226	2	0	5	0	7	0	372	1	0	373	1	0	1	0	2	608
07:15	3	200	2	0	205	2	0	2	1	5	0	378	1	0	379	1	0	2	0	3	592
07:30	1	238	0	0	239	1	0	2	0	3	0	428	0	0	428	0	0	2	0	2	672
07:45	1	222	1	0	224	0	0	6	0	6	0	392	1	0	393	0	0	1	0	1	624
Total Volume	6	885	3	0	894	5	0	15	1	21	0	1570	3	0	1573	2	0	6	0	8	2496
% App. Total	0.7	99	0.3	0		23.8	0	71.4	4.8		0	99.8	0.2	0		25	0	75	0		
PHF	.500	.930	.375	.000	.935	.625	.000	.625	.250	.750	.000	.917	.750	.000	.919	.500	.000	.750	.000	.667	.929

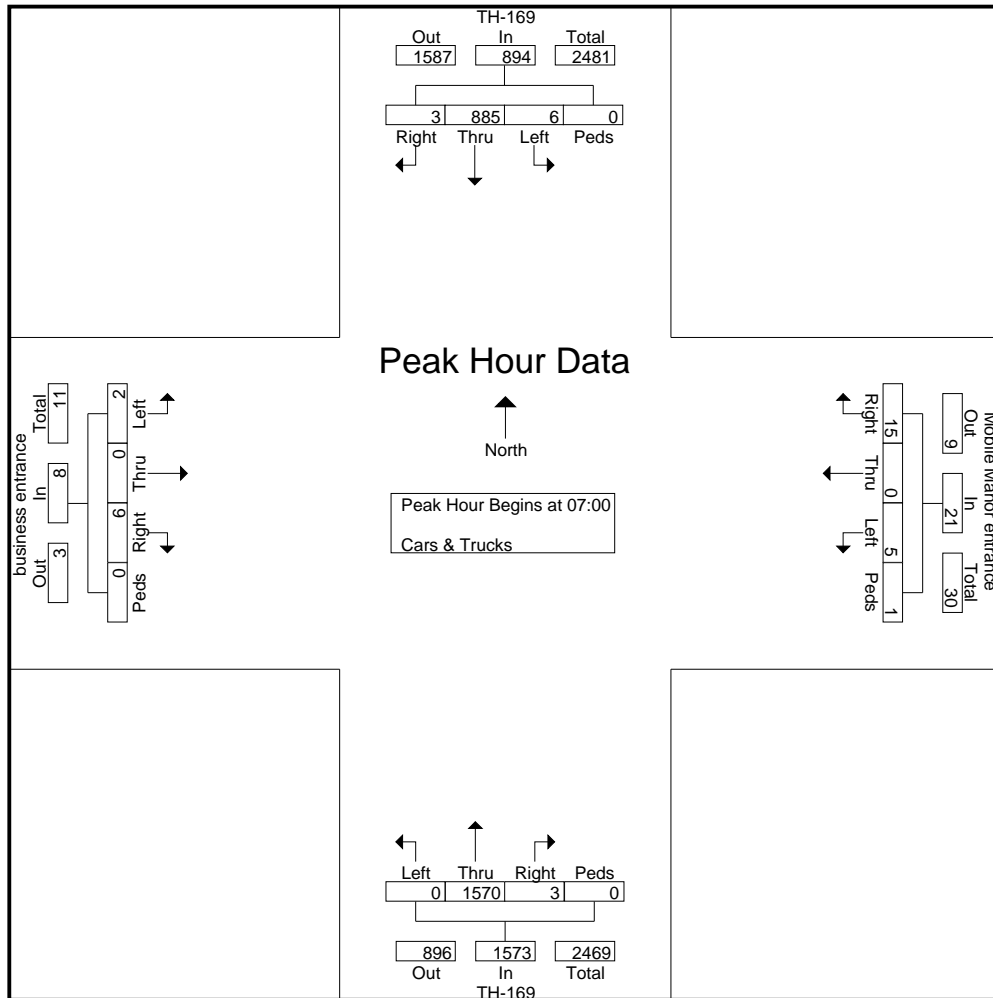



# MINNESOTA DEPT OF TRANSPORTATION

## TRAFFIC DATA COLLECTION - METRO

TH-169 at Mobile Manor entrance  
 Ref.Pt.: 107.030  
 Jx  
 JAMAR # T2582  
 TURN MOVEMENT COUNT

File Name : TH-169 at Mobile Manor 2012  
 Site Code : 00000001  
 Start Date : 6/6/2012  
 Page No : 3

Start Time	TH-169 Southbound					Mobile Manor entrance Westbound					TH-169 Northbound					business entrance Eastbound					Int. Total
	Left	Thru	Right	Peds	App. Total	Left	Thru	Right	Peds	App. Total	Left	Thru	Right	Peds	App. Total	Left	Thru	Right	Peds	App. Total	
16:30	4	446	0	0	450	0	0	0	0	0	1	246	1	0	248	2	0	0	0	2	700
16:45	3	461	1	0	465	2	0	3	0	5	0	260	4	0	264	2	0	0	0	2	736
17:00	2	428	1	1	432	1	0	3	0	4	0	251	5	0	256	1	0	1	1	3	695
17:15	6	432	0	0	438	1	0	1	0	2	0	281	4	0	285	4	0	2	0	6	731
Total Volume	15	1767	2	1	1785	4	0	7	0	11	1	1038	14	0	1053	9	0	3	1	13	2862
% App. Total	0.8	.99	0.1	0.1		36.4	0	63.6	0		0.1	98.6	1.3	0		69.2	0	23.1	7.7		
PHF	.625	.958	.500	.250	.960	.500	.000	.583	.000	.550	.250	.923	.700	.000	.924	.563	.000	.375	.250	.542	.972

Peak Hour Analysis From 15:00 to 17:45 - Peak 1 of 1  
 Peak Hour for Entire Intersection Begins at 16:30

