

Alliant Engineering

Minneapolis, MN 55415

--TRAFFIC DATA --

I-494 at TH-156 / Concord, south ramps

Ref.Pt.: 000.000

data by Alliant Engineering

TURN MOVEMENT COUNT

File Name : 507 - TH 156 and I-494 S Ramp

Site Code : 507

Start Date : 4/14/2015

Page No : 1

Groups Printed- Cars - Trucks

Start Time	Hwy 156 / Concord Southbound				n/a Westbound				Hwy 156 / Concord Northbound				ramp from / loop to I-494 EB Eastbound				Int. Total
	Left	Thru	Rght	Bikes	Left	Thru	Rght	Bikes	Left	Thru	Rght	Bikes	Left	Thru	Rght	Bikes	
06:00	0	43	3	0	0	0	0	0	42	42	0	0	24	0	19	0	173
06:15	0	44	18	0	0	0	0	0	37	67	0	0	18	0	19	0	203
06:30	0	53	25	0	0	0	0	0	37	72	0	0	31	0	22	0	240
06:45	0	42	10	0	0	0	0	0	23	55	0	0	47	0	44	0	221
Total	0	182	56	0	0	0	0	0	139	236	0	0	120	0	104	0	837
07:00	0	62	18	0	0	0	0	0	56	81	0	0	42	0	32	0	291
07:15	0	60	26	0	0	0	0	0	47	97	0	0	42	0	23	0	295
07:30	0	63	14	0	0	0	0	0	58	101	0	0	33	0	30	0	299
07:45	0	67	24	0	0	0	0	0	36	76	0	0	48	0	47	0	298
Total	0	252	82	0	0	0	0	0	197	355	0	0	165	0	132	0	1183
08:00	0	70	16	0	0	0	0	0	38	75	0	3	36	0	26	0	264
08:15	0	58	18	0	0	0	0	0	41	67	0	0	48	0	34	0	266
08:30	0	75	22	0	0	0	0	0	36	66	0	1	37	0	35	0	272
08:45	0	60	17	0	0	0	0	0	33	73	0	0	37	0	37	1	258
Total	0	263	73	0	0	0	0	0	148	281	0	4	158	0	132	1	1060
09:00	0	52	12	0	0	0	0	0	25	61	0	0	37	0	25	0	212
09:15	0	64	19	0	0	0	0	0	20	64	0	0	30	0	25	0	222
09:30	0	39	16	0	0	0	0	0	25	65	0	0	37	0	32	0	214
09:45	0	46	17	0	0	0	0	0	31	62	0	1	43	0	34	0	234
Total	0	201	64	0	0	0	0	0	101	252	0	1	147	0	116	0	882
10:00	0	38	24	1	0	0	0	0	21	56	0	1	42	0	23	1	207
10:15	0	64	15	0	0	0	0	0	32	52	0	0	35	0	24	1	223
10:30	0	56	21	0	0	0	0	0	26	55	0	0	35	0	24	0	217
10:45	0	58	22	0	0	0	0	0	21	50	0	1	39	0	24	0	215
Total	0	216	82	1	0	0	0	0	100	213	0	2	151	0	95	2	862
11:00	0	56	25	0	0	0	0	0	19	54	0	1	47	0	25	0	227
11:15	0	66	23	0	0	0	0	0	21	63	0	1	39	0	33	0	246
11:30	0	73	18	0	0	0	0	0	18	58	0	0	34	0	25	0	226
11:45	0	79	24	0	0	0	0	0	32	58	0	0	34	0	33	0	260
Total	0	274	90	0	0	0	0	0	90	233	0	2	154	0	116	0	959
12:00	0	67	19	0	0	0	0	0	21	67	0	1	41	0	33	0	249
12:15	0	77	20	0	0	0	0	0	28	60	0	0	30	0	32	0	247
12:30	0	76	27	0	0	0	0	0	33	59	0	1	27	0	42	0	265
12:45	0	56	11	0	0	0	0	0	17	61	0	2	46	0	39	0	232
Total	0	276	77	0	0	0	0	0	99	247	0	4	144	0	146	0	993
13:00	0	58	26	0	0	0	0	0	39	72	0	0	32	0	29	0	256
13:15	0	75	21	0	0	0	0	0	27	60	0	0	36	0	35	1	255
13:30	0	75	22	0	0	0	0	0	34	65	0	0	32	0	33	0	261
13:45	0	69	22	0	0	0	0	0	26	69	0	0	29	0	46	0	261
Total	0	277	91	0	0	0	0	0	126	266	0	0	129	0	143	1	1033
14:00	0	69	20	0	0	0	0	0	31	73	0	0	37	0	45	0	275
14:15	0	72	27	0	0	0	0	0	42	72	0	0	46	0	41	0	300
14:30	0	74	38	0	0	0	0	0	34	71	0	0	41	0	45	0	303
14:45	0	119	43	0	0	0	0	0	52	66	0	0	48	0	56	0	384
Total	0	334	128	0	0	0	0	0	159	282	0	0	172	0	187	0	1262
15:00	0	117	33	0	0	0	0	0	51	81	0	1	36	0	62	0	381
15:15	0	129	37	0	0	0	0	0	67	75	0	0	25	0	72	0	405
15:30	0	119	46	0	0	0	0	0	60	84	0	0	40	0	56	0	405
15:45	0	117	40	0	0	0	0	0	45	76	0	1	39	0	76	0	394
Total	0	482	156	0	0	0	0	0	223	316	0	2	140	0	266	0	1585

Alliant Engineering

Minneapolis, MN 55415

--TRAFFIC DATA --

I-494 at TH-156 / Concord, south ramps

Ref.Pt.: 000.000

data by Alliant Engineering

TURN MOVEMENT COUNT

File Name : 507 - TH 156 and I-494 S Ramp

Site Code : 507

Start Date : 4/14/2015

Page No : 2

Groups Printed- Cars - Trucks

Start Time	Hwy 156 / Concord Southbound				n/a Westbound				Hwy 156 / Concord Northbound				ramp from / loop to I-494 EB Eastbound				Int. Total
	Left	Thru	Rght	Bikes	Left	Thru	Rght	Bikes	Left	Thru	Rght	Bikes	Left	Thru	Rght	Bikes	
16:00	0	142	34	0	0	0	0	0	50	84	0	0	34	0	52	0	396
16:15	0	119	43	0	0	0	0	0	52	92	0	1	23	0	42	0	372
16:30	0	128	44	0	0	0	0	0	55	85	0	0	24	0	46	0	382
16:45	0	104	42	0	0	0	0	0	54	71	0	0	26	0	38	0	335
Total	0	493	163	0	0	0	0	0	211	332	0	1	107	0	178	0	1485
17:00	0	126	34	0	0	0	0	0	53	79	0	1	35	0	34	0	362
17:15	0	127	43	0	0	0	0	0	62	79	0	0	29	0	31	0	371
17:30	0	84	50	0	0	0	0	0	58	56	0	0	32	0	43	0	323
17:45	0	126	36	0	0	0	0	0	49	64	0	1	35	0	30	0	341
Total	0	463	163	0	0	0	0	0	222	278	0	2	131	0	138	0	1397
*** BREAK ***																	
Grand Total	0	3713	1225	1	0	0	0	0	1815	3291	0	18	1718	0	1753	4	13538
Apprch %	0	75.2	24.8	0	0	0	0	0	35.4	64.2	0	0.4	49.4	0	50.4	0.1	
Total %	0	27.4	9	0	0	0	0	0	13.4	24.3	0	0.1	12.7	0	12.9	0	
Cars	0	3501	1167	1	0	0	0	0	1717	3050	0	17	1600	0	1547	4	12604
% Cars	0	94.3	95.3	100	0	0	0	0	94.6	92.7	0	94.4	93.1	0	88.2	100	93.1
Trucks	0	212	58	0	0	0	0	0	98	241	0	1	118	0	206	0	934
% Trucks	0	5.7	4.7	0	0	0	0	0	5.4	7.3	0	5.6	6.9	0	11.8	0	6.9

Alliant Engineering

Minneapolis, MN 55415

--TRAFFIC DATA --

I-494 at TH-156 / Concord, south ramps
 Ref.Pt.: 000.000
 data by Alliant Engineering
 TURN MOVEMENT COUNT

File Name : 507 - TH 156 and I-494 S Ramp
 Site Code : 507
 Start Date : 4/14/2015
 Page No : 3

Start Time	Hwy 156 / Concord Southbound					n/a Westbound					Hwy 156 / Concord Northbound					ramp from / loop to I-494 EB Eastbound					Int. Total
	Left	Thru	Right	Bikes	App. Total	Left	Thru	Right	Bikes	App. Total	Left	Thru	Right	Bikes	App. Total	Left	Thru	Right	Bikes	App. Total	
Peak Hour Analysis From 06:00 to 11:45 - Peak 1 of 1																					
Peak Hour for Entire Intersection Begins at 07:00																					
07:00	0	62	18	0	80	0	0	0	0	0	56	81	0	0	137	42	0	32	0	74	291
07:15	0	60	26	0	86	0	0	0	0	0	47	97	0	0	144	42	0	23	0	65	295
07:30	0	63	14	0	77	0	0	0	0	0	58	101	0	0	159	33	0	30	0	63	299
07:45	0	67	24	0	91	0	0	0	0	0	36	76	0	0	112	48	0	47	0	95	298
Total Volume	0	252	82	0	334	0	0	0	0	0	197	355	0	0	552	165	0	132	0	297	1183
% App. Total	0	75.4	24.6	0		0	0	0	0	0	35.7	64.3	0	0		55.6	0	44.4	0		
PHF	.000	.940	.788	.000	.918	.000	.000	.000	.000	.000	.849	.879	.000	.000	.868	.859	.000	.702	.000	.782	.989

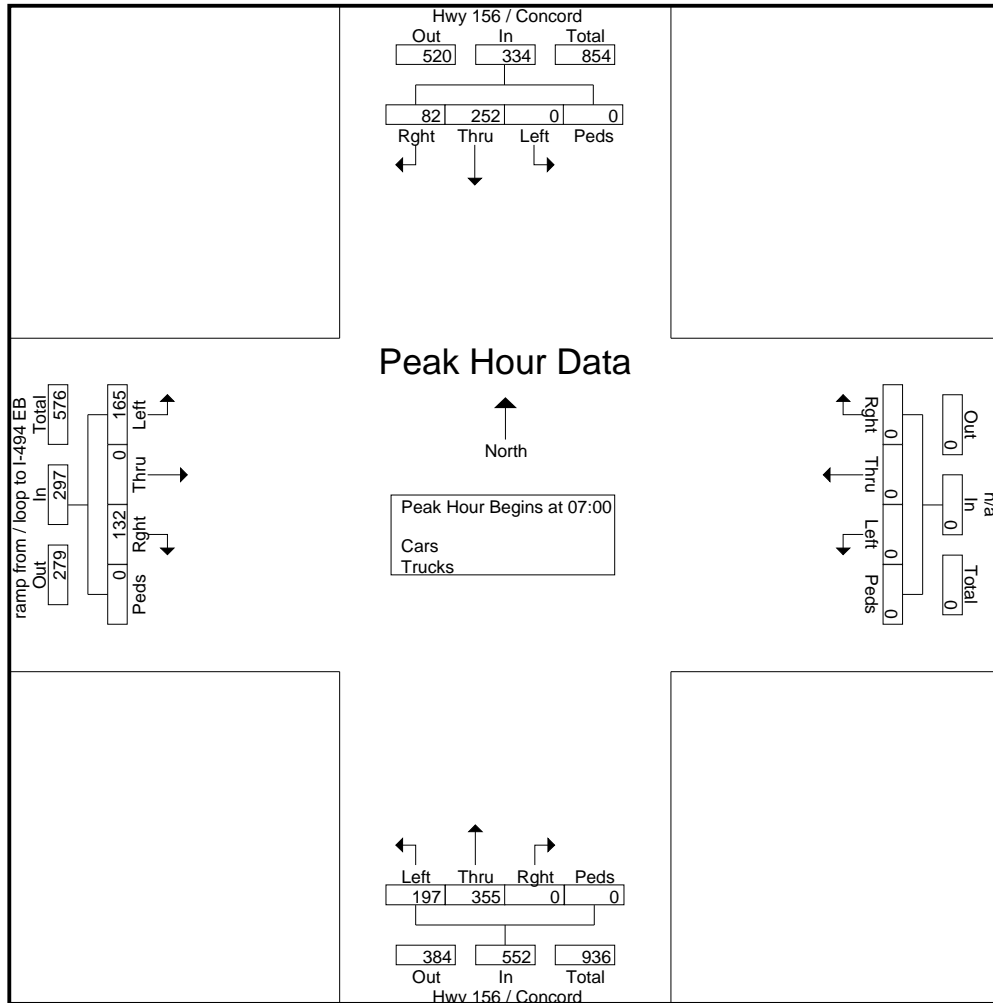

Alliant Engineering

Minneapolis, MN 55415

--TRAFFIC DATA --

I-494 at TH-156 / Concord, south ramps

Ref.Pt.: 000.000

data by Alliant Engineering

TURN MOVEMENT COUNT

File Name : 507 - TH 156 and I-494 S Ramp

Site Code : 507

Start Date : 4/14/2015

Page No : 4

Start Time	Hwy 156 / Concord Southbound					n/a Westbound					Hwy 156 / Concord Northbound					ramp from / loop to I-494 EB Eastbound					Int. Total
	Left	Thru	Rght	Bikes	App. Total	Left	Thru	Rght	Bikes	App. Total	Left	Thru	Rght	Bikes	App. Total	Left	Thru	Rght	Bikes	App. Total	
Peak Hour Analysis From 12:00 to 18:00 - Peak 1 of 1																					
Peak Hour for Entire Intersection Begins at 15:15																					
15:15	0	129	37	0	166	0	0	0	0	0	67	75	0	0	142	25	0	72	0	97	405
15:30	0	119	46	0	165	0	0	0	0	0	60	84	0	0	144	40	0	56	0	96	405
15:45	0	117	40	0	157	0	0	0	0	0	45	76	0	1	122	39	0	76	0	115	394
16:00	0	142	34	0	176	0	0	0	0	0	50	84	0	0	134	34	0	52	0	86	396
Total Volume	0	507	157	0	664	0	0	0	0	0	222	319	0	1	542	138	0	256	0	394	1600
% App. Total	0	76.4	23.6	0		0	0	0	0		41	58.9	0	0.2		35	0	65	0		
PHF	.000	.893	.853	.000	.943	.000	.000	.000	.000	.000	.828	.949	.000	.250	.941	.863	.000	.842	.000	.857	.988

