

Alliant Engineering

Minneapolis, MN 55415

--TRAFFIC DATA --

TH-149 at Lone Oak Pkwy

File Name : 108 - TH 149 & Lone Oak Pkwy

Site Code : 108

BY: Alliant Eng.

Start Date : 11/18/2014

TURN MOVEMENT COUNT

Page No : 1

Groups Printed- Cars - Trucks

Start Time	TH 149 Southbound				Lone Oak Pkwy Westbound				TH 149 Northbound				Lone Oak Pkwy Eastbound				Int. Total
	Left	Thru	Rght	Bikes	Left	Thru	Rght	Bikes	Left	Thru	Rght	Bikes	Left	Thru	Rght	Bikes	
06:00	27	57	5	0	1	0	1	0	0	54	14	0	0	0	0	0	159
06:15	44	75	13	0	1	0	1	0	3	70	9	0	2	0	1	0	219
06:30	49	79	16	0	1	0	1	0	8	84	7	0	2	1	1	0	249
06:45	62	103	15	0	0	2	2	0	8	101	24	0	3	3	2	0	325
Total	182	314	49	0	3	2	5	0	19	309	54	0	7	4	4	0	952
07:00	54	92	15	0	2	2	2	0	34	101	7	0	5	2	6	0	322
07:15	50	105	21	0	6	4	5	0	15	135	33	0	12	1	2	0	389
07:30	76	146	24	0	2	1	2	0	13	137	29	0	9	3	2	0	444
07:45	79	167	29	0	2	1	3	0	25	130	22	0	3	1	5	0	467
Total	259	510	89	0	12	8	12	0	87	503	91	0	29	7	15	0	1622
08:00	67	121	45	0	0	0	7	0	17	135	19	0	18	4	13	0	446
08:15	57	90	36	0	1	0	4	0	17	110	15	0	23	6	13	0	372
08:30	50	90	30	0	1	1	3	0	15	90	11	0	20	7	23	0	341
08:45	37	93	23	0	0	1	7	0	7	76	9	0	19	1	21	0	294
Total	211	394	134	0	2	2	21	0	56	411	54	0	80	18	70	0	1453
09:00	38	78	34	0	2	1	6	0	11	95	3	0	21	4	9	0	302
09:15	33	78	34	0	0	1	1	0	9	111	7	0	18	4	13	0	309
*** BREAK ***																	
Total	71	156	68	0	2	2	7	0	20	206	10	0	39	8	22	0	611
*** BREAK ***																	
10:30	10	56	5	0	1	2	7	0	6	76	6	0	8	2	5	0	184
10:45	5	55	12	0	3	1	8	0	3	64	2	0	7	1	7	0	168
Total	15	111	17	0	4	3	15	0	9	140	8	0	15	3	12	0	352
11:00	7	49	4	0	0	6	15	0	12	71	6	0	10	4	5	0	189
11:15	1	67	13	0	7	2	14	0	18	66	5	0	8	1	11	0	213
11:30	10	62	9	0	1	8	25	0	9	75	1	0	12	6	14	0	232
11:45	16	63	7	0	1	4	13	0	7	91	3	0	7	3	15	0	230
Total	34	241	33	0	9	20	67	0	46	303	15	0	37	14	45	0	864
12:00	30	85	23	0	7	6	16	0	12	61	2	0	10	7	9	0	268
12:15	19	81	23	0	3	3	14	0	10	88	6	0	16	9	12	0	284
12:30	29	87	15	0	3	1	14	0	10	74	3	0	10	4	16	0	266
12:45	17	86	15	0	3	2	6	0	18	57	3	0	10	3	11	0	231
Total	95	339	76	0	16	12	50	0	50	280	14	0	46	23	48	0	1049
13:00	15	72	22	0	1	3	11	0	6	69	3	0	12	3	6	0	223
13:15	11	96	19	0	4	2	13	0	11	48	3	1	12	8	5	0	233
*** BREAK ***																	
Total	26	168	41	0	5	5	24	0	17	117	6	1	24	11	11	0	456
*** BREAK ***																	
14:30	11	64	11	0	8	1	29	0	8	118	2	0	16	0	5	0	273
14:45	9	80	12	0	6	0	20	0	3	111	3	0	11	4	4	0	263
Total	20	144	23	0	14	1	49	0	11	229	5	0	27	4	9	0	536
15:00	9	82	8	0	8	3	43	0	6	94	5	0	16	0	5	0	279
15:15	9	100	8	0	9	1	27	0	8	111	2	0	11	2	7	0	295
15:30	8	95	9	0	9	4	52	0	5	148	5	0	19	3	13	0	370
15:45	15	84	10	0	8	1	49	0	3	115	5	0	12	0	11	0	313
Total	41	361	35	0	34	9	171	0	22	468	17	0	58	5	36	0	1257
16:00	13	77	10	0	12	0	60	0	4	136	0	0	24	1	10	0	347
16:15	5	108	8	0	13	2	71	0	4	137	6	0	12	7	9	0	382
16:30	9	100	4	0	14	0	73	0	6	166	0	0	25	1	15	0	413

Alliant Engineering

Minneapolis, MN 55415

--TRAFFIC DATA --

TH-149 at Lone Oak Pkwy

File Name : 108 - TH 149 & Lone Oak Pkwy

Site Code : 108

BY: Alliant Eng.

Start Date : 11/18/2014

TURN MOVEMENT COUNT

Page No : 2

Groups Printed- Cars - Trucks

Start Time	TH 149 Southbound				Lone Oak Pkwy Westbound				TH 149 Northbound				Lone Oak Pkwy Eastbound				Int. Total
	Left	Thru	Rght	Bikes	Left	Thru	Rght	Bikes	Left	Thru	Rght	Bikes	Left	Thru	Rght	Bikes	
16:45	6	128	7	0	9	6	86	0	8	154	0	0	13	3	11	0	431
Total	33	413	29	0	48	8	290	0	22	593	6	0	74	12	45	0	1573
17:00	5	129	3	0	14	2	66	0	11	157	3	0	12	2	13	0	417
17:15	7	136	7	0	11	0	58	0	8	122	3	0	14	2	8	0	376
17:30	3	139	2	0	8	0	56	0	10	152	1	0	15	0	9	0	395
17:45	3	91	1	0	10	0	35	0	6	125	4	0	10	0	9	0	294
Total	18	495	13	0	43	2	215	0	35	556	11	0	51	4	39	0	1482
Grand Total	1005	3646	607	0	192	74	926	0	394	4115	291	1	487	113	356	0	12207
Apprch %	19.1	69.3	11.5	0	16.1	6.2	77.7	0	8.2	85.7	6.1	0	50.9	11.8	37.2	0	
Total %	8.2	29.9	5	0	1.6	0.6	7.6	0	3.2	33.7	2.4	0	4	0.9	2.9	0	
Cars	995	3141	602	0	176	68	907	0	388	3662	275	1	483	111	354	0	11163
% Cars	99	86.1	99.2	0	91.7	91.9	97.9	0	98.5	89	94.5	100	99.2	98.2	99.4	0	91.4
Trucks	10	505	5	0	16	6	19	0	6	453	16	0	4	2	2	0	1044
% Trucks	1	13.9	0.8	0	8.3	8.1	2.1	0	1.5	11	5.5	0	0.8	1.8	0.6	0	8.6

Alliant Engineering

Minneapolis, MN 55415

--TRAFFIC DATA --

TH-149 at Lone Oak Pkwy

File Name : 108 - TH 149 & Lone Oak Pkwy

Site Code : 108

BY: Alliant Eng.

Start Date : 11/18/2014

TURN MOVEMENT COUNT

Page No : 3

Start Time	TH 149 Southbound					Lone Oak Pkwy Westbound					TH 149 Northbound					Lone Oak Pkwy Eastbound					Int. Total
	Left	Thru	Rght	Bikes	App. Total	Left	Thru	Rght	Bikes	App. Total	Left	Thru	Rght	Bikes	App. Total	Left	Thru	Rght	Bikes	App. Total	
Peak Hour Analysis From 06:00 to 11:45 - Peak 1 of 1																					
Peak Hour for Entire Intersection Begins at 07:15																					
07:15	50	105	21	0	176	6	4	5	0	15	15	135	33	0	183	12	1	2	0	15	389
07:30	76	146	24	0	246	2	1	2	0	5	13	137	29	0	179	9	3	2	0	14	444
07:45	79	167	29	0	275	2	1	3	0	6	25	130	22	0	177	3	1	5	0	9	467
08:00	67	121	45	0	233	0	0	7	0	7	17	135	19	0	171	18	4	13	0	35	446
Total Volume	272	539	119	0	930	10	6	17	0	33	70	537	103	0	710	42	9	22	0	73	1746
% App. Total	29.2	58	12.8	0		30.3	18.2	51.5	0		9.9	75.6	14.5	0		57.5	12.3	30.1	0		
PHF	.861	.807	.661	.000	.845	.417	.375	.607	.000	.550	.700	.980	.780	.000	.970	.583	.563	.423	.000	.521	.935

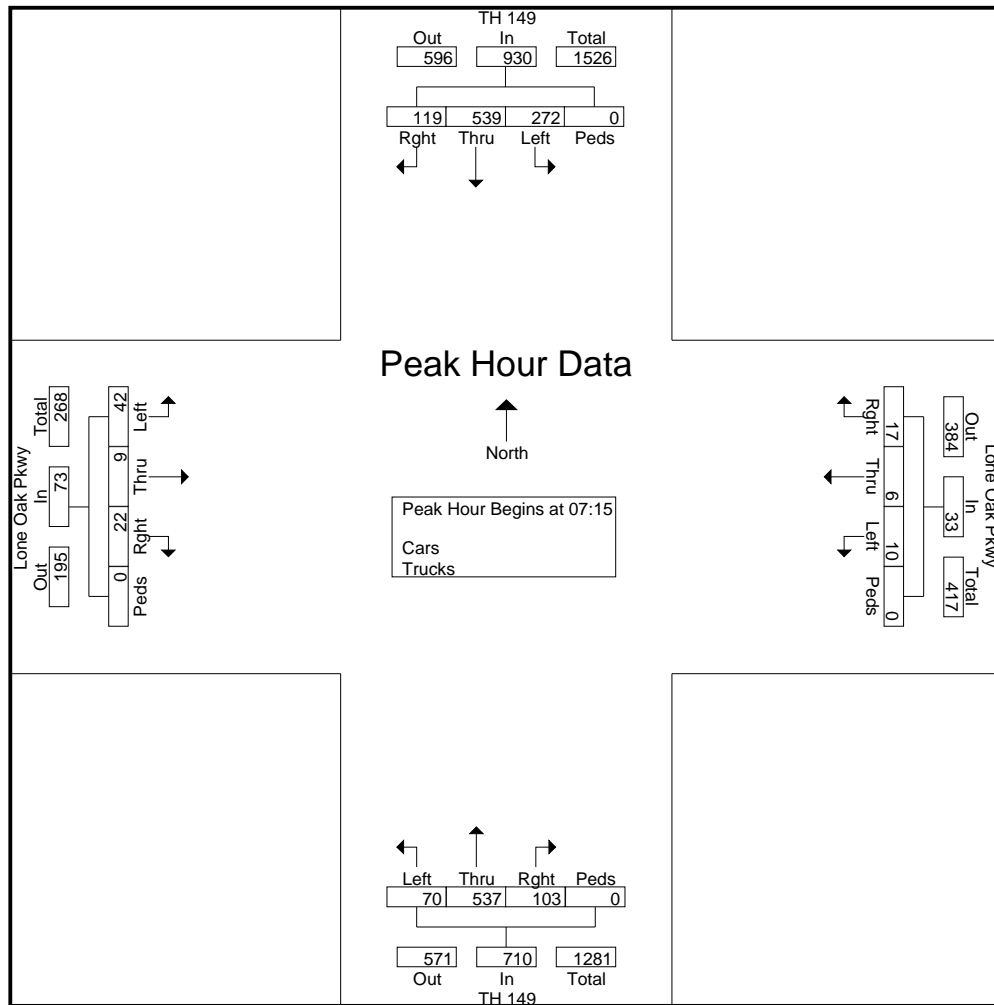

Alliant Engineering

Minneapolis, MN 55415

--TRAFFIC DATA --

TH-149 at Lone Oak Pkwy

File Name : 108 - TH 149 & Lone Oak Pkwy

Site Code : 108

BY: Alliant Eng.

Start Date : 11/18/2014

TURN MOVEMENT COUNT

Page No : 4

Start Time	TH 149 Southbound					Lone Oak Pkwy Westbound					TH 149 Northbound					Lone Oak Pkwy Eastbound					Int. Total
	Left	Thru	Rght	Bikes	App. Total	Left	Thru	Rght	Bikes	App. Total	Left	Thru	Rght	Bikes	App. Total	Left	Thru	Rght	Bikes	App. Total	
Peak Hour Analysis From 12:00 to 17:45 - Peak 1 of 1																					
Peak Hour for Entire Intersection Begins at 16:15																					
16:15	5	108	8	0	121	13	2	71	0	86	4	137	6	0	147	12	7	9	0	28	382
16:30	9	100	4	0	113	14	0	73	0	87	6	166	0	172	25	1	15	0	41	413	
16:45	6	128	7	0	141	9	6	86	0	101	8	154	0	162	13	3	11	0	27	431	
17:00	5	129	3	0	137	14	2	66	0	82	11	157	3	171	12	2	13	0	27	417	
Total Volume	25	465	22	0	512	50	10	296	0	356	29	614	9	652	62	13	48	0	123	1643	
% App. Total	4.9	90.8	4.3	0		14	2.8	83.1	0		4.4	94.2	1.4		50.4	10.6	39	0			
PHF	.694	.901	.688	.000	.908	.893	.417	.860	.000	.881	.659	.925	.375	.000	.948	.620	.464	.800	.000	.750	.953

