

Alliant Engineering

Minneapolis, MN 55415

--TRAFFIC DATA --

TH--149 at Yankee Doodle Rd.

File Name : 115 - TH 149 & Yankee Doodle Rd

BY: Alliant Eng.

Site Code : 115

TURN MOVEMENT COUNT

Start Date : 12/3/2014

Page No : 1

Groups Printed- Cars - Trucks

Start Time	TH 149 Southbound				Yankee Doodle Rd Westbound				TH 149 Northbound				Yankee Doodle Rd Eastbound				Int. Total
	Left	Thru	Rght	Bikes	Left	Thru	Rght	Bikes	Left	Thru	Rght	Bikes	Left	Thru	Rght	Bikes	
06:00	2	30	4	0	19	29	3	0	16	74	0	0	2	7	26	0	212
06:15	1	56	11	0	26	37	0	0	21	99	0	0	2	14	23	0	290
06:30	3	61	10	0	30	54	5	0	27	117	8	0	7	19	57	0	398
06:45	2	91	6	0	32	70	0	0	37	131	1	0	4	18	57	0	449
Total	8	238	31	0	107	190	8	0	101	421	9	0	15	58	163	0	1349
07:00	3	95	16	0	40	59	2	0	37	145	1	0	4	32	73	0	507
07:15	2	101	19	0	36	62	10	0	47	172	3	0	1	42	62	0	557
07:30	7	158	30	0	43	75	3	0	54	180	4	0	3	47	96	0	700
07:45	1	185	17	0	43	98	5	0	76	172	3	0	12	49	123	0	784
Total	13	539	82	0	162	294	20	0	214	669	11	0	20	170	354	0	2548
08:00	6	159	18	0	38	70	9	0	37	137	1	0	5	35	109	0	624
08:15	3	163	6	0	36	47	6	0	49	145	1	0	4	33	115	0	608
08:30	3	130	7	0	27	50	3	0	34	119	1	0	3	25	109	0	511
08:45	5	136	24	0	26	47	1	0	29	73	4	0	6	39	115	0	505
Total	17	588	55	0	127	214	19	0	149	474	7	0	18	132	448	0	2248
09:00	5	101	22	0	21	39	5	0	43	83	2	0	10	19	69	0	419
09:15	8	95	17	0	14	39	5	0	100	100	2	0	2	32	61	0	475
09:30	0	20	0	0	0	0	0	0	0	31	0	0	0	0	0	0	51
09:45	0	14	0	0	0	0	0	0	0	10	0	0	0	0	0	0	24
Total	13	230	39	0	35	78	10	0	143	224	4	0	12	51	130	0	969
10:00	0	13	0	0	0	0	0	0	0	6	0	0	0	0	0	0	19
10:15	0	18	0	0	0	0	0	0	0	10	0	0	0	0	0	0	28
10:30	7	38	26	0	10	21	5	0	42	47	2	0	1	22	23	0	244
10:45	4	44	26	0	5	41	4	0	23	37	5	0	7	27	33	0	256
Total	11	113	52	0	15	62	9	0	65	100	7	0	8	49	56	0	547
11:00	4	36	27	0	4	29	0	0	34	48	7	0	2	31	30	0	252
11:15	3	50	29	0	2	30	0	0	34	49	9	0	1	22	23	0	252
11:30	3	43	35	0	9	37	2	0	45	63	4	0	4	36	27	0	308
11:45	2	53	46	0	1	24	4	0	39	42	4	0	3	33	23	0	274
Total	12	182	137	0	16	120	6	0	152	202	24	0	10	122	103	0	1086
12:00	9	49	31	0	6	45	3	0	44	45	3	0	2	49	35	0	321
12:15	7	54	36	0	1	25	1	0	33	53	4	0	4	32	29	0	279
12:30	6	43	35	0	6	33	4	0	27	61	6	0	2	43	39	0	305
12:45	6	42	29	0	2	22	6	0	35	51	2	0	3	34	42	0	274
Total	28	188	131	0	15	125	14	0	139	210	15	0	11	158	145	0	1179
13:00	5	44	23	0	7	40	3	0	37	57	3	0	1	24	26	0	270
13:15	3	31	18	0	3	57	9	0	40	51	1	0	1	35	40	0	289
13:30	0	11	0	0	0	0	0	0	0	10	0	0	0	0	0	0	21
13:45	0	7	0	0	0	0	0	0	0	5	0	0	0	0	0	0	12
Total	8	93	41	0	10	97	12	0	77	123	4	0	2	59	66	0	592
14:00	0	11	0	0	0	0	0	0	0	6	0	0	0	0	0	0	17
14:15	0	8	0	0	0	0	0	0	0	6	0	0	0	0	0	0	14
14:30	4	65	18	0	3	38	4	0	56	76	13	0	1	58	28	8	372
14:45	3	75	20	0	12	37	6	0	42	87	14	0	1	51	42	0	390
Total	7	159	38	0	15	75	10	0	98	175	27	0	2	109	70	8	793
15:00	5	88	33	0	7	35	3	0	53	106	18	0	4	53	34	0	439
15:15	6	96	30	0	5	50	5	0	57	91	17	0	4	52	37	0	450
15:30	4	117	38	0	2	44	3	0	81	95	18	0	3	61	53	0	519
15:45	10	124	30	0	9	45	3	0	71	92	21	0	5	62	53	0	525
Total	25	425	131	0	23	174	14	0	262	384	74	0	16	228	177	0	1933

Alliant Engineering

Minneapolis, MN 55415

--TRAFFIC DATA --

TH--149 at Yankee Doodle Rd.

File Name : 115 - TH 149 & Yankee Doodle Rd

Site Code : 115

BY: Alliant Eng.

Start Date : 12/3/2014

TURN MOVEMENT COUNT

Page No : 2

Groups Printed- Cars - Trucks

Start Time	TH 149 Southbound				Yankee Doodle Rd Westbound				TH 149 Northbound				Yankee Doodle Rd Eastbound				Int. Total
	Left	Thru	Rght	Bikes	Left	Thru	Rght	Bikes	Left	Thru	Rght	Bikes	Left	Thru	Rght	Bikes	
16:00	5	88	39	0	3	54	2	0	82	129	34	0	4	66	48	0	554
16:15	9	113	31	1	2	57	3	0	97	159	24	0	2	88	46	0	632
16:30	2	134	32	0	3	36	2	0	119	164	37	0	1	102	49	0	681
16:45	7	154	29	0	5	56	6	0	96	134	35	0	1	92	45	0	660
Total	23	489	131	1	13	203	13	0	394	586	130	0	8	348	188	0	2527
17:00	1	144	43	0	3	79	0	0	132	171	41	0	3	96	48	0	761
17:15	9	147	28	0	4	90	9	0	130	126	28	0	3	102	52	0	728
17:30	11	131	24	0	7	65	5	0	75	115	44	0	5	72	57	0	611
17:45	4	102	27	0	8	42	7	0	106	119	28	0	12	72	46	0	573
Total	25	524	122	0	22	276	21	0	443	531	141	0	23	342	203	0	2673
Grand Total	190	3768	990	1	560	1908	156	0	2237	4099	453	0	145	1826	2103	8	18444
Apprch %	3.8	76.1	20	0	21.3	72.7	5.9	0	33	60.4	6.7	0	3.6	44.7	51.5	0.2	
Total %	1	20.4	5.4	0	3	10.3	0.8	0	12.1	22.2	2.5	0	0.8	9.9	11.4	0	
Cars	126	3514	876	0	533	1835	125	0	2094	3815	431	0	106	1751	2010	8	17224
% Cars	66.3	93.3	88.5	0	95.2	96.2	80.1	0	93.6	93.1	95.1	0	73.1	95.9	95.6	100	93.4
Trucks	64	254	114	1	27	73	31	0	143	284	22	0	39	75	93	0	1220
% Trucks	33.7	6.7	11.5	100	4.8	3.8	19.9	0	6.4	6.9	4.9	0	26.9	4.1	4.4	0	6.6

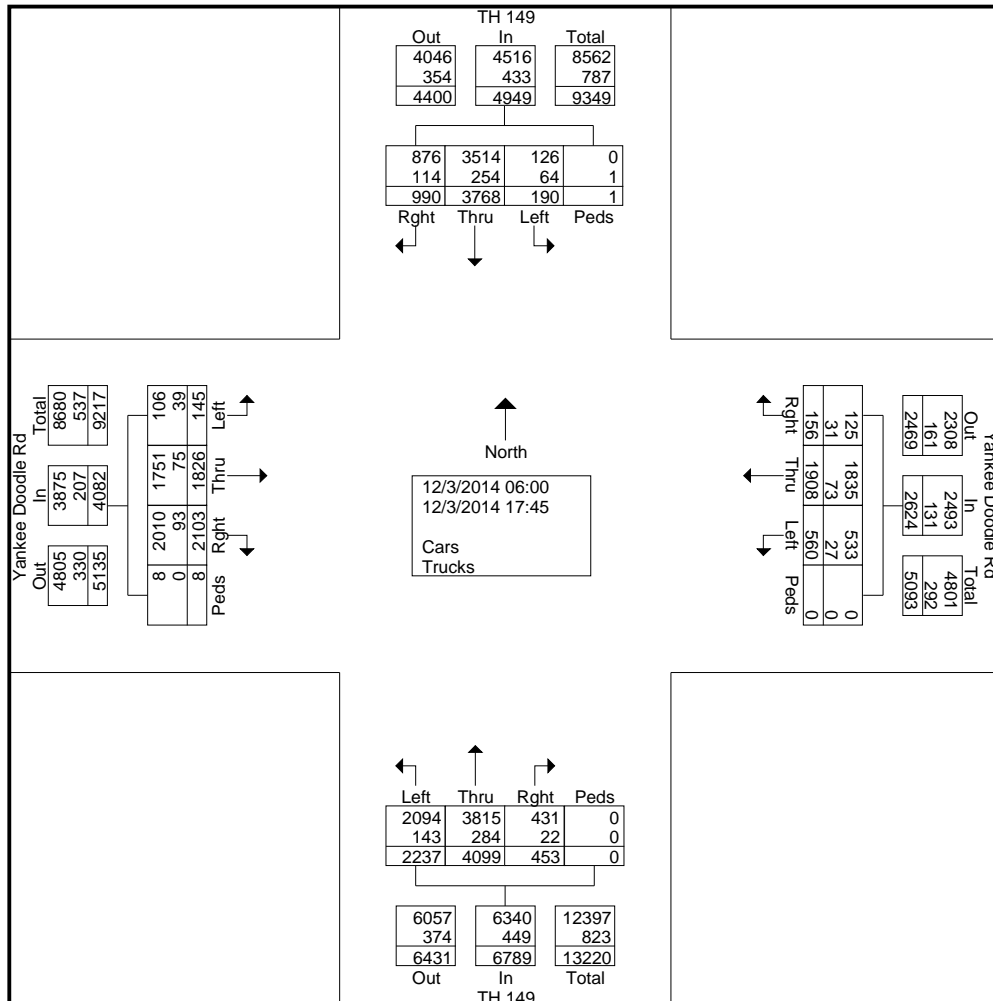

Alliant Engineering

Minneapolis, MN 55415

--TRAFFIC DATA --

TH--149 at Yankee Doodle Rd.

File Name : 115 - TH 149 & Yankee Doodle Rd

Site Code : 115

BY: Alliant Eng.

Start Date : 12/3/2014

TURN MOVEMENT COUNT

Page No : 3

Start Time	TH 149 Southbound					Yankee Doodle Rd Westbound					TH 149 Northbound					Yankee Doodle Rd Eastbound					Int. Total
	Left	Thru	Rght	Bikes	App. Total	Left	Thru	Rght	Bikes	App. Total	Left	Thru	Rght	Bikes	App. Total	Left	Thru	Rght	Bikes	App. Total	
Peak Hour Analysis From 06:00 to 11:45 - Peak 1 of 1																					
Peak Hour for Entire Intersection Begins at 07:30																					
07:30	7	158	30	0	195	43	75	3	0	121	54	180	4	0	238	3	47	96	0	146	700
07:45	1	185	17	0	203	43	98	5	0	146	76	172	3	0	251	12	49	123	0	184	784
08:00	6	159	18	0	183	38	70	9	0	117	37	137	1	0	175	5	35	109	0	149	624
08:15	3	163	6	0	172	36	47	6	0	89	49	145	1	0	195	4	33	115	0	152	608
Total Volume	17	665	71	0	753	160	290	23	0	473	216	634	9	0	859	24	164	443	0	631	2716
% App. Total	2.3	88.3	9.4	0		33.8	61.3	4.9	0		25.1	73.8	1	0		3.8	26	70.2	0		
PHF	.607	.899	.592	.000	.927	.930	.740	.639	.000	.810	.711	.881	.563	.000	.856	.500	.837	.900	.000	.857	.866

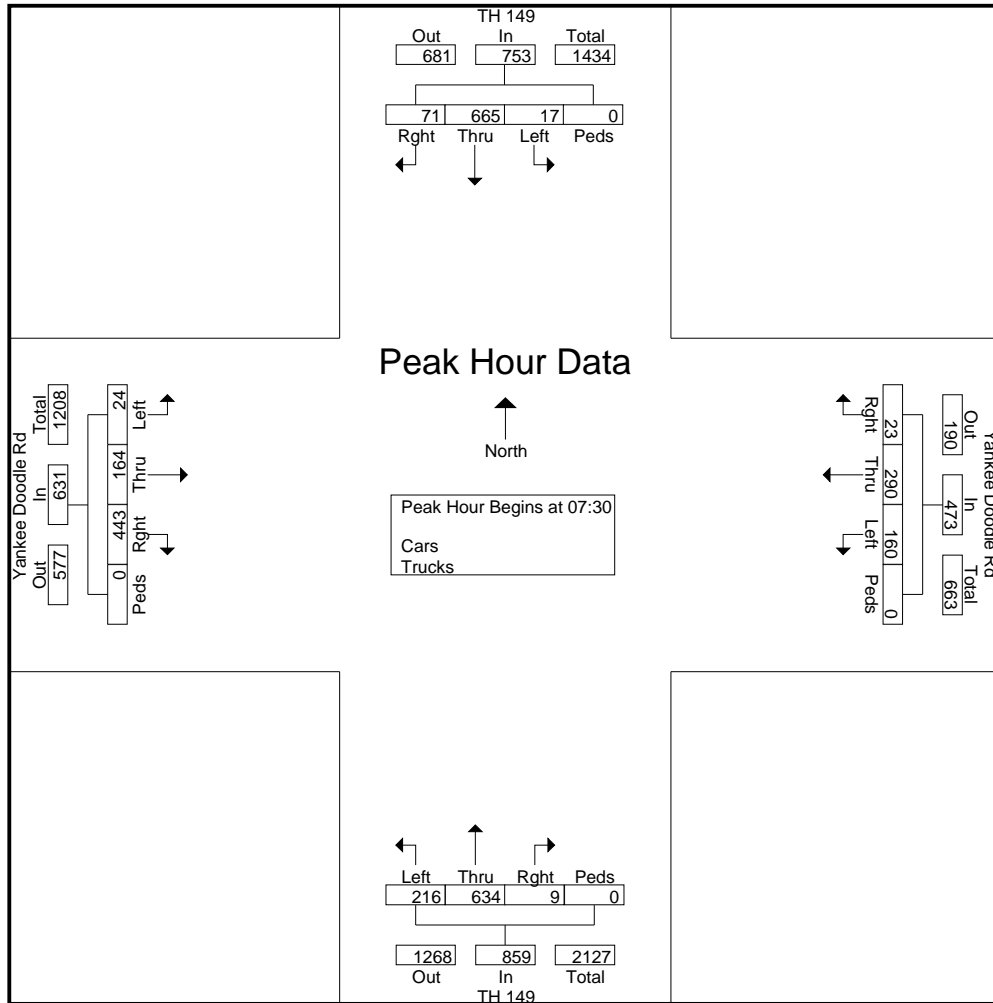

Alliant Engineering

Minneapolis, MN 55415

--TRAFFIC DATA --

TH--149 at Yankee Doodle Rd.

File Name : 115 - TH 149 & Yankee Doodle Rd

Site Code : 115

BY: Alliant Eng.

Start Date : 12/3/2014

TURN MOVEMENT COUNT

Page No : 4

Start Time	TH 149 Southbound					Yankee Doodle Rd Westbound					TH 149 Northbound					Yankee Doodle Rd Eastbound					Int. Total
	Left	Thru	Rght	Bikes	App. Total	Left	Thru	Rght	Bikes	App. Total	Left	Thru	Rght	Bikes	App. Total	Left	Thru	Rght	Bikes	App. Total	
Peak Hour Analysis From 12:00 to 17:45 - Peak 1 of 1																					
Peak Hour for Entire Intersection Begins at 16:30																					
16:30	2	134	32	0	168	3	36	2	0	41	119	164	37	0	320	1	102	49	0	152	681
16:45	7	154	29	0	190	5	56	6	0	67	96	134	35	0	265	1	92	45	0	138	660
17:00	1	144	43	0	188	3	79	0	0	82	132	171	41	0	344	3	96	48	0	147	761
17:15	9	147	28	0	184	4	90	9	0	103	130	126	28	0	284	3	102	52	0	157	728
Total Volume	19	579	132	0	730	15	261	17	0	293	477	595	141	0	1213	8	392	194	0	594	2830
% App. Total	2.6	79.3	18.1	0		5.1	89.1	5.8	0		39.3	49.1	11.6	0		1.3	66	32.7	0		
PHF	.528	.940	.767	.000	.961	.750	.725	.472	.000	.711	.903	.870	.860	.000	.882	.667	.961	.933	.000	.946	.930

