

# Alliant Engineering

Minneapolis, MN 55415

--TRAFFIC DATA --

TH-13 at Pilot Knob Rd.

File Name : 102 - TH 13 & Pilot Knob Rd

Site Code : 102

BY: Alliant Eng.

Start Date : 12/3/2014

TURN MOVEMENT COUNT

Page No : 1

Groups Printed- Cars - Trucks

Start Time	TH 13 Southbound				Pilot Knob Rd Westbound				TH 13 Northbound				Pilot Knob Rd Eastbound				Int. Total
	Left	Thru	Rght	Bikes	Left	Thru	Rght	Bikes	Left	Thru	Rght	Bikes	Left	Thru	Rght	Bikes	
06:00	10	12	2	0	0	6	30	0	1	22	1	0	0	1	0	0	85
06:15	20	13	3	0	2	7	19	0	1	46	1	0	0	3	1	0	116
06:30	18	21	2	0	0	4	23	0	8	43	1	0	0	1	2	0	123
06:45	39	19	4	0	0	20	53	0	8	59	1	0	0	6	3	0	212
Total	87	65	11	0	2	37	125	0	18	170	4	0	0	11	6	0	536
07:00	21	20	7	0	1	19	74	0	4	72	1	0	2	6	1	0	228
07:15	32	20	6	0	0	19	62	0	6	87	2	0	0	5	4	0	243
07:30	56	42	12	0	1	17	73	0	4	134	4	0	2	6	2	0	353
07:45	42	33	19	0	1	29	73	0	7	109	7	0	2	9	7	0	338
Total	151	115	44	0	3	84	282	0	21	402	14	0	6	26	14	0	1162
08:00	36	34	16	0	2	17	51	0	6	87	6	0	3	7	4	0	269
08:15	35	43	17	0	4	24	45	0	6	64	3	0	0	9	6	0	256
08:30	37	32	11	0	3	7	40	0	5	50	3	0	5	9	2	0	204
08:45	38	48	8	0	0	10	20	0	3	51	4	0	4	7	2	0	195
Total	146	157	52	0	9	58	156	0	20	252	16	0	12	32	14	0	924
09:00	30	28	8	0	1	4	16	0	4	41	3	0	4	4	2	0	145
09:15	27	28	10	0	1	14	27	0	8	29	4	0	3	5	2	0	158
09:30	0	0	1	0	0	0	0	0	0	0	0	0	0	0	0	0	1
*** BREAK ***																	
Total	57	56	19	0	2	18	43	0	12	70	7	0	7	9	4	0	304
*** BREAK ***																	
10:30	14	14	6	0	3	7	23	0	6	26	1	0	4	6	1	4	115
10:45	23	26	5	0	3	12	15	0	1	29	2	0	3	5	6	0	130
Total	37	40	11	0	6	19	38	0	7	55	3	0	7	11	7	4	245
11:00	10	23	8	0	3	9	18	0	0	25	2	0	7	8	4	0	117
11:15	20	27	1	0	2	8	18	0	5	46	2	0	2	7	8	0	146
11:30	12	13	7	0	5	9	29	0	2	30	3	0	3	21	4	0	138
11:45	23	27	6	0	4	8	26	0	5	32	3	0	2	14	5	0	155
Total	65	90	22	0	14	34	91	0	12	133	10	0	14	50	21	0	556
12:00	14	26	3	0	6	15	27	0	1	26	4	0	5	14	4	0	145
12:15	15	33	6	0	6	14	18	0	3	27	1	0	3	8	2	0	136
12:30	19	25	6	0	2	11	23	0	4	37	3	0	2	8	5	0	145
12:45	28	26	3	0	2	13	17	0	2	24	4	0	5	14	3	0	141
Total	76	110	18	0	16	53	85	0	10	114	12	0	15	44	14	0	567
13:00	22	27	5	0	2	18	22	0	5	24	0	0	4	17	5	0	151
13:15	18	32	7	0	2	15	17	0	7	22	5	0	2	13	6	0	146
13:30	0	0	0	0	0	0	0	0	0	1	0	0	0	0	0	0	1
*** BREAK ***																	
Total	40	59	12	0	4	33	39	0	12	47	5	0	6	30	11	0	298
*** BREAK ***																	
14:30	18	44	8	0	8	18	25	0	3	52	4	0	18	15	4	0	217
14:45	33	24	8	0	1	4	28	2	6	49	3	0	6	9	3	0	176
Total	51	68	16	0	9	22	53	2	9	101	7	0	24	24	7	0	393
15:00	26	39	5	0	6	12	19	0	1	39	3	0	11	14	6	0	181
15:15	48	48	4	0	1	5	27	0	0	37	2	0	8	9	7	0	196
15:30	36	46	3	0	8	13	51	0	0	56	1	0	6	14	14	0	248
15:45	32	48	0	0	3	11	36	0	0	45	2	0	7	18	9	0	211
Total	142	181	12	0	18	41	133	0	1	177	8	0	32	55	36	0	836
16:00	58	68	4	0	4	9	41	0	4	55	3	0	7	15	7	0	275

# Alliant Engineering

Minneapolis, MN 55415

--TRAFFIC DATA --

TH-13 at Pilot Knob Rd.

File Name : 102 - TH 13 & Pilot Knob Rd

Site Code : 102

Start Date : 12/3/2014

Page No : 2

BY: Alliant Eng.

TURN MOVEMENT COUNT

Groups Printed- Cars - Trucks

Start Time	TH 13 Southbound				Pilot Knob Rd Westbound				TH 13 Northbound				Pilot Knob Rd Eastbound				Int. Total
	Left	Thru	Right	Bikes	Left	Thru	Right	Bikes	Left	Thru	Right	Bikes	Left	Thru	Right	Bikes	
16:15	43	80	3	0	5	5	38	0	1	52	6	0	4	16	5	0	258
16:30	73	99	3	0	7	12	42	0	2	60	2	0	16	16	5	0	337
16:45	45	96	3	0	5	5	52	0	1	79	1	0	9	12	12	0	320
Total	219	343	13	0	21	31	173	0	8	246	12	0	36	59	29	0	1190
17:00	51	83	1	0	6	6	78	0	1	84	2	0	10	16	11	0	349
17:15	50	98	3	0	3	9	49	0	0	66	1	0	8	12	3	0	302
17:30	43	73	6	0	2	4	32	0	0	45	6	0	9	10	6	0	236
17:45	41	69	1	0	1	1	40	0	0	61	0	0	7	6	2	0	229
Total	185	323	11	0	12	20	199	0	1	256	9	0	34	44	22	0	1116
Grand Total	1256	1607	241	0	116	450	1417	2	131	2023	107	0	193	395	185	4	8127
Apprch %	40.5	51.8	7.8	0	5.8	22.7	71.4	0.1	5.8	89.5	4.7	0	24.8	50.8	23.8	0.5	
Total %	15.5	19.8	3	0	1.4	5.5	17.4	0	1.6	24.9	1.3	0	2.4	4.9	2.3	0	
Cars	1245	1543	230	0	86	418	1408	2	100	1942	78	0	188	363	151	4	7758
% Cars	99.1	96	95.4	0	74.1	92.9	99.4	100	76.3	96	72.9	0	97.4	91.9	81.6	100	95.5
Trucks	11	64	11	0	30	32	9	0	31	81	29	0	5	32	34	0	369
% Trucks	0.9	4	4.6	0	25.9	7.1	0.6	0	23.7	4	27.1	0	2.6	8.1	18.4	0	4.5

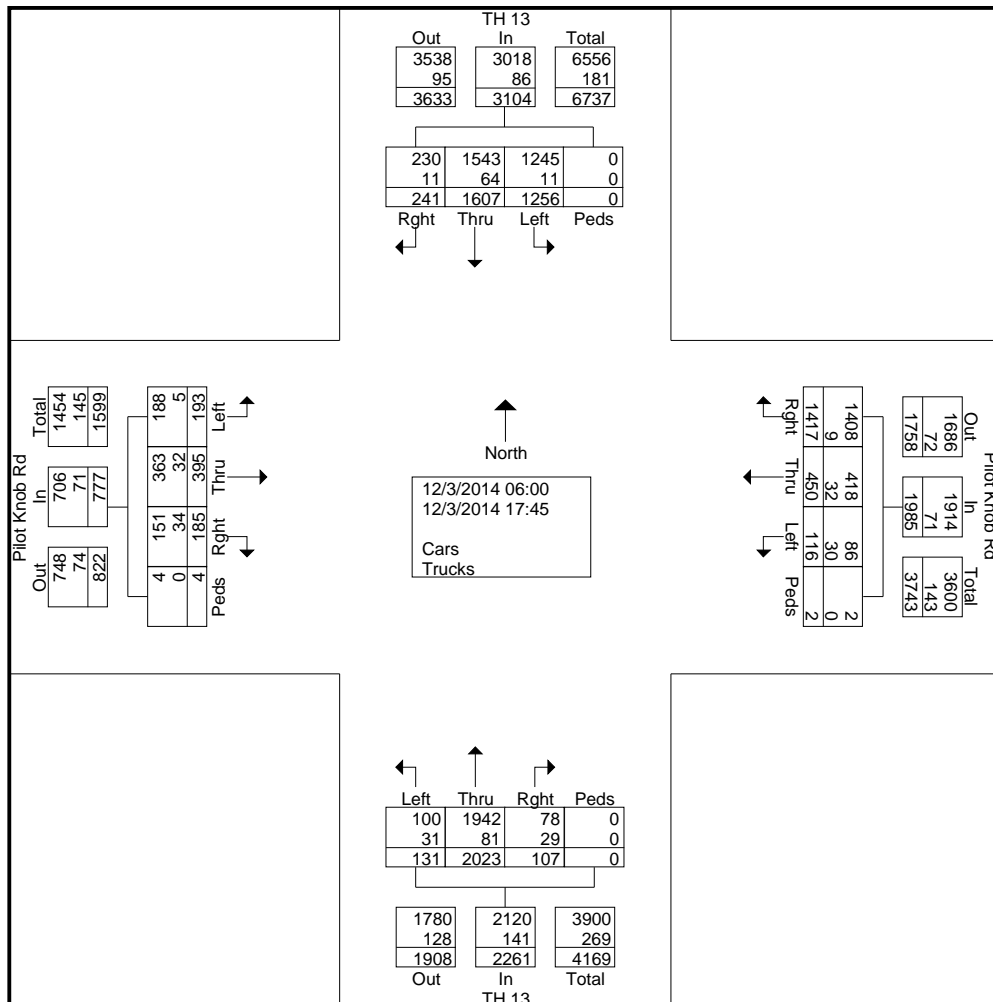

# Alliant Engineering

Minneapolis, MN 55415

--TRAFFIC DATA --

TH-13 at Pilot Knob Rd.

File Name : 102 - TH 13 & Pilot Knob Rd

Site Code : 102

Start Date : 12/3/2014

BY: Alliant Eng.

Page No : 3

TURN MOVEMENT COUNT

Start Time	TH 13 Southbound					Pilot Knob Rd Westbound					TH 13 Northbound					Pilot Knob Rd Eastbound					Int. Total
	Left	Thru	Right	Bikes	App. Total	Left	Thru	Right	Bikes	App. Total	Left	Thru	Right	Bikes	App. Total	Left	Thru	Right	Bikes	App. Total	
Peak Hour Analysis From 06:00 to 11:45 - Peak 1 of 1																					
Peak Hour for Entire Intersection Begins at 07:30																					
07:30	56	42	12	0	110	1	17	73	0	91	4	134	4	0	142	2	6	2	0	10	353
07:45	42	33	19	0	94	1	29	73	0	103	7	109	7	0	123	2	9	7	0	18	338
08:00	36	34	16	0	86	2	17	51	0	70	6	87	6	0	99	3	7	4	0	14	269
08:15	35	43	17	0	95	4	24	45	0	73	6	64	3	0	73	0	9	6	0	15	256
Total Volume	169	152	64	0	385	8	87	242	0	337	23	394	20	0	437	7	31	19	0	57	1216
% App. Total	43.9	39.5	16.6	0		2.4	25.8	71.8	0		5.3	90.2	4.6	0		12.3	54.4	33.3	0		
PHF	.754	.884	.842	.000	.875	.500	.750	.829	.000	.818	.821	.735	.714	.000	.769	.583	.861	.679	.000	.792	.861

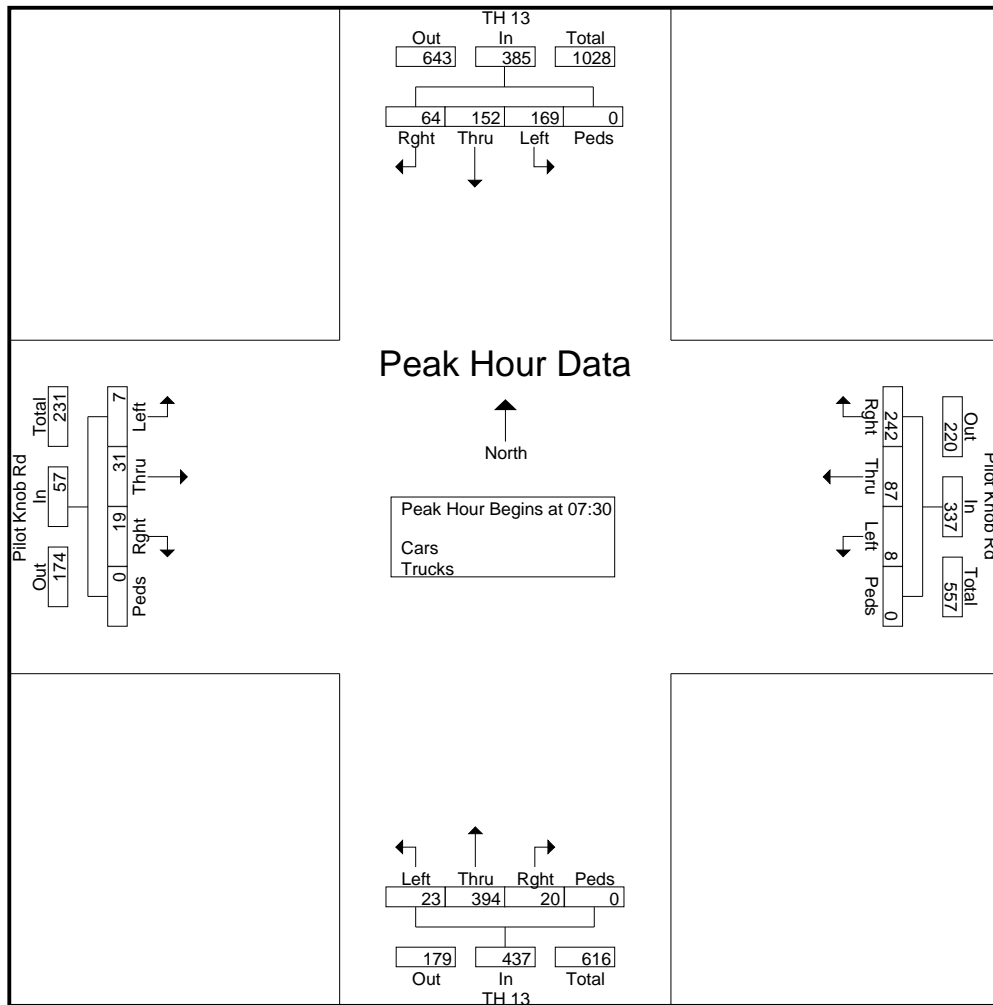

# Alliant Engineering

Minneapolis, MN 55415

--TRAFFIC DATA --

TH-13 at Pilot Knob Rd.

File Name : 102 - TH 13 & Pilot Knob Rd

Site Code : 102

BY: Alliant Eng.

Start Date : 12/3/2014

TURN MOVEMENT COUNT

Page No : 4

Start Time	TH 13 Southbound					Pilot Knob Rd Westbound					TH 13 Northbound					Pilot Knob Rd Eastbound					Int. Total
	Left	Thru	Rght	Bikes	App. Total	Left	Thru	Rght	Bikes	App. Total	Left	Thru	Rght	Bikes	App. Total	Left	Thru	Rght	Bikes	App. Total	
Peak Hour Analysis From 12:00 to 17:45 - Peak 1 of 1																					
Peak Hour for Entire Intersection Begins at 16:30																					
16:30	73	99	3	0	175	7	12	42	0	61	2	60	2	0	64	16	16	5	0	37	337
16:45	45	96	3	0	144	5	5	52	0	62	1	79	1	0	81	9	12	12	0	33	320
17:00	51	83	1	0	135	6	6	78	0	90	1	84	2	0	87	10	16	11	0	37	349
17:15	50	98	3	0	151	3	9	49	0	61	0	66	1	0	67	8	12	3	0	23	302
Total Volume	219	376	10	0	605	21	32	221	0	274	4	289	6	0	299	43	56	31	0	130	1308
% App. Total	36.2	62.1	1.7	0		7.7	11.7	80.7	0		1.3	96.7	2	0		33.1	43.1	23.8	0		
PHF	.750	.949	.833	.000	.864	.750	.667	.708	.000	.761	.500	.860	.750	.000	.859	.672	.875	.646	.000	.878	.937

