

SEH CONSULTING
Traffic Data Collection
TURN MOVEMENT COUNT

Burnsville Parkway at Nicollet Avenue
AM, MID, PM Peaks 6/27/2007
data by SEH
TURN MOVEMENT COUNT

File Name : Burnsville Pkwy at Nicollet Ave 2007
Site Code : 00000005
Start Date : 6/27/2007
Page No : 1

Groups Printed- Unshifted

Start Time	Nicollet Ave Southbound				Burnsville Pkwy Westbound				Nicollet Ave Northbound				Burnsville Pkwy Eastbound				Exclu. Total	Inclu. Total	Int. Total
	Left	Thru	Right	Peds	Left	Thru	Right	Peds	Left	Thru	Right	Peds	Left	Thru	Right	Peds			
06:00	1	6	4	0	6	21	14	0	25	63	3	0	20	29	4	0	0	196	196
06:15	3	8	7	1	0	27	13	2	20	96	11	0	27	34	10	1	4	256	260
06:30	4	18	9	2	8	50	17	1	28	144	11	1	31	55	10	1	5	385	390
06:45	3	18	9	0	7	51	18	0	34	172	14	1	54	86	22	1	2	488	490
Total	11	50	29	3	21	149	62	3	107	475	39	2	132	204	46	3	11	1325	1336
07:00	8	23	7	2	8	44	7	0	44	210	15	0	38	79	13	0	2	496	498
07:15	7	17	12	0	13	57	24	1	45	250	33	1	40	75	13	2	4	586	590
07:30	8	21	23	0	20	76	16	0	71	213	29	1	38	143	24	3	4	682	686
07:45	10	30	16	2	15	110	12	3	64	198	40	1	48	140	26	0	6	709	715
Total	33	91	58	4	56	287	59	4	224	871	117	3	164	437	76	5	16	2473	2489
08:00	4	40	20	1	14	67	13	0	64	133	36	0	43	103	40	2	3	577	580
08:15	6	51	20	0	22	70	16	0	57	117	14	1	27	87	31	0	1	518	519
08:30	5	34	10	0	21	64	13	1	41	99	12	0	24	58	47	3	4	428	432
08:45	3	40	26	0	27	81	10	0	59	92	19	0	35	60	52	1	1	504	505
Total	18	165	76	1	84	282	52	1	221	441	81	1	129	308	170	6	9	2027	2036
*** BREAK ***																			
11:00	13	56	25	1	19	64	11	0	37	76	19	0	23	47	40	0	1	430	431
11:15	8	66	35	2	35	49	9	1	46	83	25	0	24	60	36	1	4	476	480
11:30	4	82	37	3	34	60	6	1	52	76	27	0	29	78	46	3	7	531	538
11:45	5	95	44	4	40	63	14	1	48	79	20	0	30	83	53	0	5	574	579
Total	30	299	141	10	128	236	40	3	183	314	91	0	106	268	175	4	17	2011	2028
12:00	13	76	44	0	32	54	10	0	52	91	44	0	24	72	60	1	1	572	573
12:15	7	85	42	1	33	56	17	1	40	85	37	0	30	76	57	7	9	565	574
12:30	5	85	19	2	30	69	9	8	54	93	34	7	36	87	65	5	22	586	608
12:45	7	90	38	5	22	79	8	3	65	92	37	0	31	73	54	1	9	596	605
Total	32	336	143	8	117	258	44	12	211	361	152	7	121	308	236	14	41	2319	2360
*** BREAK ***																			
15:00	7	74	8	0	33	57	7	0	32	64	17	0	17	81	64	0	0	461	461
15:15	15	76	14	0	34	67	8	0	34	59	32	0	31	84	58	0	0	512	512
15:30	20	74	15	0	33	62	5	0	38	87	44	0	25	94	68	0	0	565	565
15:45	22	90	18	0	25	93	8	0	36	57	18	0	24	85	66	0	0	542	542
Total	64	314	55	0	125	279	28	0	140	267	111	0	97	344	256	0	0	2080	2080
16:00	22	136	30	0	31	68	13	0	46	50	28	0	30	87	87	0	0	628	628
16:15	21	103	24	0	27	89	14	0	52	74	29	0	28	113	89	0	0	663	663
16:30	21	143	41	0	41	96	12	0	45	80	36	0	31	93	96	0	0	735	735
16:45	22	104	28	0	37	101	12	0	48	58	30	0	19	109	80	0	0	648	648
Total	86	486	123	0	136	354	51	0	191	262	123	0	108	402	352	0	0	2674	2674
17:00	23	149	38	0	49	114	8	0	57	84	28	0	43	150	80	0	0	823	823
17:15	41	157	54	0	64	113	11	0	52	97	30	0	40	112	74	0	0	845	845
17:30	37	155	50	0	65	120	12	0	55	105	0	0	45	115	80	0	0	839	839
17:45	30	150	49	0	50	100	10	0	40	100	0	0	39	86	65	0	0	719	719
Total	131	611	191	0	228	447	41	0	204	386	58	0	167	463	299	0	0	3226	3226
Grand Total	405	2352	816	26	895	2292	377	23	1481	3377	772	13	1024	2734	1610	32	94	18135	18229
Apprch %	11.3	65.8	22.8		25.1	64.3	10.6		26.3	60	13.7		19.1	50.9	30				
Total %	2.2	13	4.5		4.9	12.6	2.1		8.2	18.6	4.3		5.6	15.1	8.9		0.5	99.5	

SEH CONSULTING
Traffic Data Collection
TURN MOVEMENT COUNT

Burnsville Parkway at Nicollet Avenue
AM, MID, PM Peaks 6/27/2007
data by SEH
TURN MOVEMENT COUNT

File Name : Burnsville Pkwy at Nicollet Ave 2007
Site Code : 00000005
Start Date : 6/27/2007
Page No : 2

Start Time	Nicollet Ave Southbound				Burnsville Pkwy Westbound				Nicollet Ave Northbound				Burnsville Pkwy Eastbound				Int. Total
	Left	Thru	Right	App. Total	Left	Thru	Right	App. Total	Left	Thru	Right	App. Total	Left	Thru	Right	App. Total	
Peak Hour Analysis From 06:00 to 08:45 - Peak 1 of 1																	
Peak Hour for Entire Intersection Begins at 07:15																	
07:15	7	17	12	36	13	57	24	94	45	250	33	328	40	75	13	128	586
07:30	8	21	23	52	20	76	16	112	71	213	29	313	38	143	24	205	682
07:45	10	30	16	56	15	110	12	137	64	198	40	302	48	140	26	214	709
08:00	4	40	20	64	14	67	13	94	64	133	36	233	43	103	40	186	577
Total Volume	29	108	71	208	62	310	65	437	244	794	138	1176	169	461	103	733	2554
% App. Total	13.9	51.9	34.1		14.2	70.9	14.9		20.7	67.5	11.7		23.1	62.9	14.1		
PHF	.725	.675	.772	.813	.775	.705	.677	.797	.859	.794	.863	.896	.880	.806	.644	.856	.901

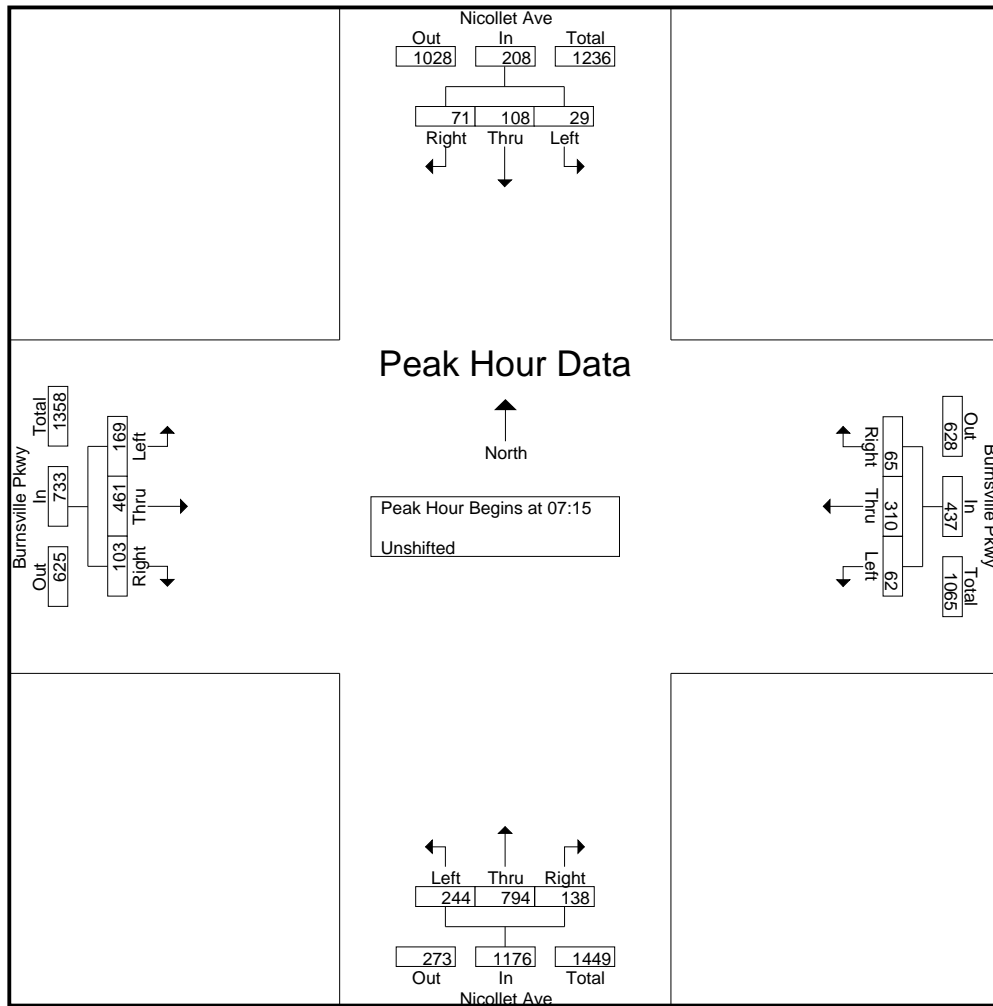

SEH CONSULTING
Traffic Data Collection
TURN MOVEMENT COUNT

Burnsville Parkway at Nicollet Avenue
AM, MID, PM Peaks 6/27/2007
data by SEH
TURN MOVEMENT COUNT

File Name : Burnsville Pkwy at Nicollet Ave 2007
Site Code : 00000005
Start Date : 6/27/2007
Page No : 3

Start Time	Nicollet Ave Southbound				Burnsville Pkwy Westbound				Nicollet Ave Northbound				Burnsville Pkwy Eastbound				Int. Total
	Left	Thru	Right	App. Total	Left	Thru	Right	App. Total	Left	Thru	Right	App. Total	Left	Thru	Right	App. Total	
Peak Hour Analysis From 15:00 to 17:45 - Peak 1 of 1																	
Peak Hour for Entire Intersection Begins at 17:00																	
17:00	23	149	38	210	49	114	8	171	57	84	28	169	43	150	80	273	823
17:15	41	157	54	252	64	113	11	188	52	97	30	179	40	112	74	226	845
17:30	37	155	50	242	65	120	12	197	55	105	0	160	45	115	80	240	839
17:45	30	150	49	229	50	100	10	160	40	100	0	140	39	86	65	190	719
Total Volume	131	611	191	933	228	447	41	716	204	386	58	648	167	463	299	929	3226
% App. Total	14	65.5	20.5		31.8	62.4	5.7		31.5	59.6	9		18	49.8	32.2		
PHF	.799	.973	.884	.926	.877	.931	.854	.909	.895	.919	.483	.905	.928	.772	.934	.851	.954

