

# MN Dept of Transportation

TRAFFIC DATA COLLECTION - Metro

TH-13 at South Park Drive (S of CSAH-42)

Ref.Pt.: 087.348

video JI

TURN MOVEMENT COUNT

File Name : TH-13 at South Park Dr SAVAGE 2014

Site Code :

Start Date : 4/23/2014

Page No : 1

Groups Printed- Cars +

Start Time	TH-13 Southbound				South Park Drive Westbound				TH-13 Northbound				South Park Drive Eastbound				Int. Total
	Left	Thru	Right	Peds	Left	Thru	Right	Peds	Left	Thru	Right	Peds	Left	Thru	Right	Peds	
06:00	3	14	1	0	3	2	14	0	1	143	1	0	3	1	0	0	186
06:15	8	29	3	0	1	1	24	0	1	148	4	0	2	1	1	0	223
06:30	12	47	2	0	3	3	31	0	3	162	2	0	8	20	0	0	293
06:45	14	96	4	0	7	5	47	0	6	211	7	0	6	0	6	0	409
Total	37	186	10	0	14	11	116	0	11	664	14	0	19	22	7	0	1111
07:00	14	122	5	0	8	13	51	0	10	236	5	0	14	0	11	0	489
07:15	27	98	10	0	8	6	40	0	8	246	12	0	16	3	6	0	480
07:30	29	119	7	0	13	10	51	0	10	217	22	0	8	4	5	0	495
07:45	42	158	7	0	8	5	52	0	14	196	16	0	15	5	6	0	524
Total	112	497	29	0	37	34	194	0	42	895	55	0	53	12	28	0	1988
08:00	23	139	5	0	5	2	39	0	17	200	20	0	6	4	14	0	474
08:15	15	95	5	0	17	8	44	0	18	172	19	0	13	3	6	0	415
08:30	22	70	9	0	9	7	42	0	15	192	26	0	18	7	8	0	425
08:45	16	70	6	0	11	0	34	0	8	148	12	0	16	5	6	0	332
Total	76	374	25	0	42	17	159	0	58	712	77	0	53	19	34	0	1646
***** BREAK *****																	
11:00	29	107	10	0	20	7	28	0	8	82	17	0	11	4	16	0	339
11:15	26	98	5	0	20	5	26	0	13	135	17	0	19	3	14	0	381
11:30	21	83	7	0	29	8	37	0	10	105	30	0	15	6	12	0	363
11:45	19	107	6	0	17	6	25	0	6	102	25	0	14	5	8	0	340
Total	95	395	28	0	86	26	116	0	37	424	89	0	59	18	50	0	1423
12:00	22	116	10	0	30	7	27	0	13	127	34	0	12	9	9	0	416
12:15	30	113	11	0	24	9	28	0	13	131	24	0	18	3	10	0	414
12:30	17	100	9	0	27	4	26	0	14	118	25	0	10	8	12	0	370
12:45	32	97	3	0	37	4	25	0	9	138	24	0	18	7	13	0	407
Total	101	426	33	0	118	24	106	0	49	514	107	0	58	27	44	0	1607
***** BREAK *****																	
15:00	27	139	8	0	32	10	31	0	11	143	24	0	11	2	22	0	460
15:15	41	155	8	0	31	19	40	0	16	138	25	0	19	9	12	0	513
15:30	35	165	9	0	46	7	33	0	12	132	23	0	17	6	17	0	502
15:45	53	169	11	0	42	3	17	0	8	121	26	0	19	13	12	0	494
Total	156	628	36	0	151	39	121	0	47	534	98	0	66	30	63	0	1969
16:00	46	208	14	0	36	10	35	0	15	161	23	0	13	14	12	0	587
16:15	48	231	14	0	29	16	33	0	14	147	26	0	16	9	17	0	600
16:30	54	215	20	0	29	8	46	0	13	102	33	0	20	9	21	0	570
16:45	52	213	14	0	40	15	48	0	15	129	27	0	26	14	24	0	617
Total	200	867	62	0	134	49	162	0	57	539	109	0	75	46	74	0	2374
17:00	94	244	18	0	41	12	40	0	16	127	29	0	22	17	23	0	683
17:15	69	250	25	0	35	7	55	0	19	132	27	0	21	8	25	0	673
17:30	75	211	14	0	47	13	41	0	10	128	32	0	23	15	28	0	637
17:45	63	244	14	0	40	11	34	0	8	129	22	0	17	14	31	0	627
Total	301	949	71	0	163	43	170	0	53	516	110	0	83	54	107	0	2620
Grand Total	1078	4322	294	0	745	243	1144	0	354	4798	659	0	466	228	407	0	14738
Apprch %	18.9	75.9	5.2	0	34.9	11.4	53.7	0	6.1	82.6	11.3	0	42.3	20.7	37	0	
Total %	7.3	29.3	2	0	5.1	1.6	7.8	0	2.4	32.6	4.5	0	3.2	1.5	2.8	0	

# MN Dept of Transportation

TRAFFIC DATA COLLECTION - Metro

TH-13 at South Park Drive (S of CSAH-42)  
 Ref.Pt.: 087.348  
 video JI  
 TURN MOVEMENT COUNT

File Name : TH-13 at South Park Dr SAVAGE 2014  
 Site Code :  
 Start Date : 4/23/2014  
 Page No : 2

Start Time	TH-13 Southbound					South Park Drive Westbound					TH-13 Northbound					South Park Drive Eastbound					Int. Total
	Left	Thru	Right	Peds	App. Total	Left	Thru	Right	Peds	App. Total	Left	Thru	Right	Peds	App. Total	Left	Thru	Right	Peds	App. Total	
Peak Hour Analysis From 06:00 to 08:45 - Peak 1 of 1																					
Peak Hour for Entire Intersection Begins at 07:00																					
07:00	14	122	5	0	141	8	13	51	0	72	10	236	5	0	251	14	0	11	0	25	489
07:15	27	98	10	0	135	8	6	40	0	54	8	246	12	0	266	16	3	6	0	25	480
07:30	29	119	7	0	155	13	10	51	0	74	10	217	22	0	249	8	4	5	0	17	495
07:45	42	158	7	0	207	8	5	52	0	65	14	196	16	0	226	15	5	6	0	26	524
Total Volume	112	497	29	0	638	37	34	194	0	265	42	895	55	0	922	53	12	28	0	93	1988
% App. Total	17.6	77.9	4.5	0		14	12.8	73.2	0		4.2	90.2	5.5	0		57	12.9	30.1	0		
PHF	.667	.786	.725	.000	.771	.712	.654	.933	.000	.895	.750	.910	.625	.000	.932	.828	.600	.636	.000	.894	.948

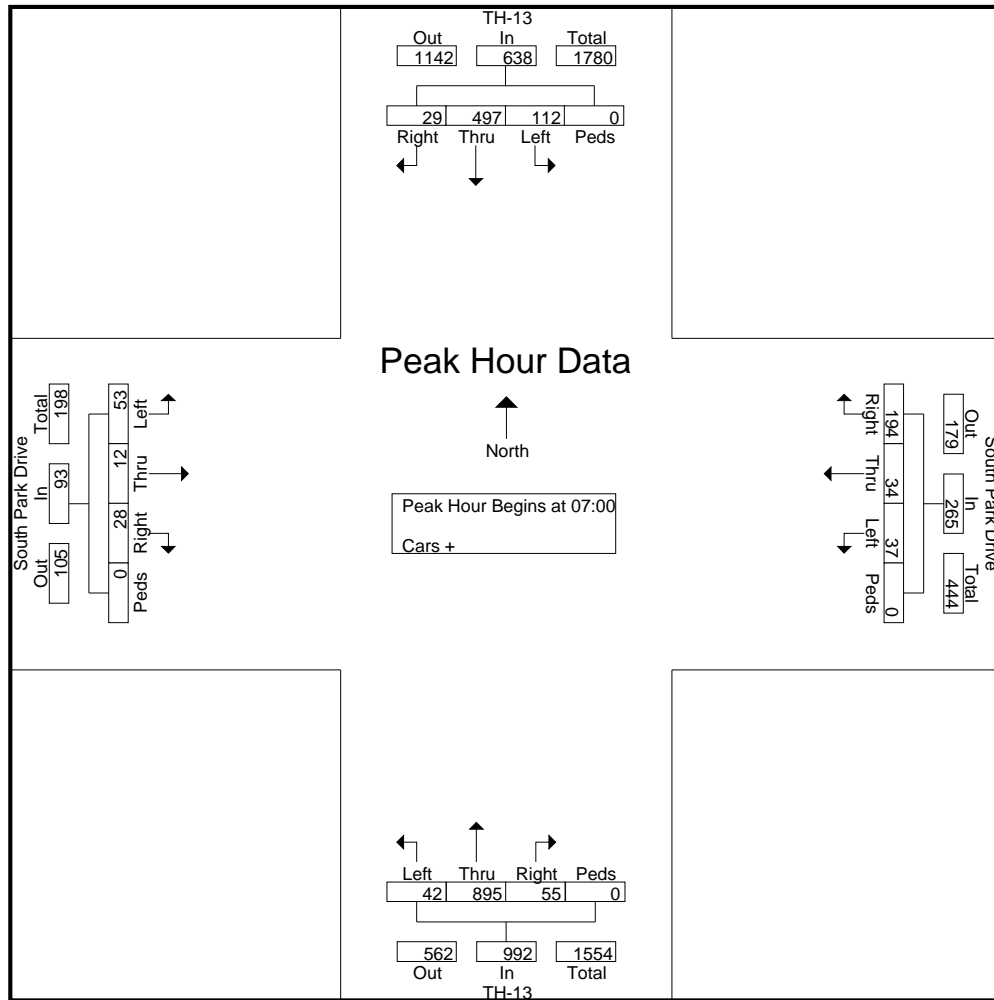

# MN Dept of Transportation

TRAFFIC DATA COLLECTION - Metro

TH-13 at South Park Drive (S of CSAH-42)  
 Ref.Pt.: 087.348  
 video JI  
 TURN MOVEMENT COUNT

File Name : TH-13 at South Park Dr SAVAGE 2014  
 Site Code :  
 Start Date : 4/23/2014  
 Page No : 3

Start Time	TH-13 Southbound					South Park Drive Westbound					TH-13 Northbound					South Park Drive Eastbound					Int. Total
	Left	Thru	Right	Peds	App. Total	Left	Thru	Right	Peds	App. Total	Left	Thru	Right	Peds	App. Total	Left	Thru	Right	Peds	App. Total	
Peak Hour Analysis From 15:00 to 17:45 - Peak 1 of 1																					
Peak Hour for Entire Intersection Begins at 17:00																					
17:00	94	244	18	0	356	41	12	40	0	93	16	127	29	0	172	22	17	23	0	62	683
17:15	69	250	25	0	344	35	7	55	0	97	19	132	27	0	178	21	8	25	0	54	673
17:30	75	211	14	0	300	47	13	41	0	101	10	128	32	0	170	23	15	28	0	66	637
17:45	63	244	14	0	321	40	11	34	0	85	8	129	22	0	159	17	14	31	0	62	627
Total Volume	301	949	71	0	1321	163	43	170	0	376	53	516	110	0	679	83	54	107	0	244	2620
% App. Total	22.8	71.8	5.4	0		43.4	11.4	45.2	0		7.8	76	16.2	0		34	22.1	43.9	0		
PHF	.801	.949	.710	.000	.928	.867	.827	.773	.000	.931	.697	.977	.859	.000	.954	.902	.794	.863	.000	.924	.959

