



MINNESOTA DEPT OF TRANSPORTATION

TRAFFIC DATA COLLECTION - METRO

TH-120 at 7th Ave E / 47th St N
 Ref.Pt.: 006.883
 Data by: JIMR
 TURN MOVEMENT COUNT

File Name : TH 120 at 7th Ave E-47th St N 2013
 Site Code :
 Start Date : 4/3/2013
 Page No : 1

Groups Printed- Cars +

Start Time	TH-120 / Century Ave Southbound				47th St N Westbound				TH-120 / Century Ave Northbound				7th Ave. E Eastbound				Int. Total
	Left	Thru	Right	Peds	Left	Thru	Right	Peds	Left	Thru	Right	Peds	Left	Thru	Right	Peds	
06:00	0	20	12	0	2	1	1	0	3	68	0	0	8	0	1	0	116
06:15	0	28	11	0	3	5	1	0	3	65	0	0	8	1	1	0	126
06:30	0	21	10	0	3	6	0	0	4	77	0	0	10	3	2	0	136
06:45	0	49	12	0	0	6	2	0	9	76	0	0	11	1	5	0	171
Total	0	118	45	0	8	18	4	0	19	286	0	0	37	5	9	0	549
07:00	0	71	12	0	0	7	1	0	8	92	0	0	10	1	3	0	205
07:15	1	64	13	0	2	5	0	0	8	100	0	0	10	4	3	0	210
07:30	0	65	18	0	3	12	1	0	3	95	0	0	16	5	4	0	222
07:45	0	67	21	0	1	22	1	0	16	106	0	0	15	3	2	0	254
Total	1	267	64	0	6	46	3	0	35	393	0	0	51	13	12	0	891
08:00	2	41	27	0	1	16	0	0	24	83	0	0	18	2	7	0	221
08:15	0	64	16	0	4	5	0	0	13	106	0	0	22	3	9	0	242
08:30	0	45	19	0	1	16	1	0	8	88	1	0	23	0	10	0	212
08:45	0	73	17	0	2	10	0	0	15	84	1	0	20	3	6	0	231
Total	2	223	79	0	8	47	1	0	60	361	2	0	83	8	32	0	906
*****BREAK*****																	
15:00	0	80	28	0	2	10	1	0	14	68	1	0	43	13	27	0	287
15:15	2	113	25	0	0	5	1	0	10	77	2	0	35	6	22	0	298
15:30	0	106	28	0	2	5	0	0	14	99	0	0	36	10	14	0	314
15:45	1	114	19	0	2	15	0	0	16	95	0	0	37	9	2	0	310
Total	3	413	100	0	6	35	2	0	54	339	3	0	151	38	65	0	1209
16:00	1	94	30	0	2	3	0	0	12	72	2	0	37	7	13	0	273
16:15	2	103	20	0	2	9	0	0	15	88	4	0	37	6	16	0	302
16:30	1	131	27	0	2	7	3	0	12	78	2	0	28	12	13	0	316
16:45	0	123	19	0	1	6	0	0	12	97	1	0	56	16	15	0	346
Total	4	451	96	0	7	25	3	0	51	335	9	0	158	41	57	0	1237
17:00	6	120	25	0	2	11	2	0	16	82	1	0	49	12	13	0	339
17:15	1	107	38	0	3	7	1	0	6	92	3	0	41	10	12	0	321
17:30	3	100	16	0	1	8	3	0	8	89	0	0	35	7	16	0	286
17:45	2	100	15	0	0	7	0	0	11	105	0	0	40	10	6	0	296
Total	12	427	94	0	6	33	6	0	41	368	4	0	165	39	47	0	1242
Grand Total	22	1899	478	0	41	204	19	0	260	2082	18	0	645	144	222	0	6034
Apprch %	0.9	79.2	19.9	0	15.5	77.3	7.2	0	11	88.2	0.8	0	63.8	14.2	22	0	
Total %	0.4	31.5	7.9	0	0.7	3.4	0.3	0	4.3	34.5	0.3	0	10.7	2.4	3.7	0	



MINNESOTA DEPT OF TRANSPORTATION

TRAFFIC DATA COLLECTION - METRO

TH-120 at 7th Ave E / 47th St N
 Ref.Pt.: 006.883
 Data by: J\NMR
 TURN MOVEMENT COUNT

File Name : TH 120 at 7th Ave E-47th St N 2013
 Site Code :
 Start Date : 4/3/2013
 Page No : 2

Start Time	TH-120 / Century Ave Southbound					47th St N Westbound					TH-120 / Century Ave Northbound					7th Ave. E Eastbound					Int. Total
	Left	Thru	Right	Peds	App. Total	Left	Thru	Right	Peds	App. Total	Left	Thru	Right	Peds	App. Total	Left	Thru	Right	Peds	App. Total	
Peak Hour Analysis From 06:00 to 08:45 - Peak 1 of 1																					
Peak Hour for Entire Intersection Begins at 07:30																					
07:30	0	65	18	0	83	3	12	1	0	16	3	95	0	0	98	16	5	4	0	25	222
07:45	0	67	21	0	88	1	22	1	0	24	16	106	0	0	122	15	3	2	0	20	254
08:00	2	41	27	0	70	1	16	0	0	17	24	83	0	0	107	18	2	7	0	27	221
08:15	0	64	16	0	80	4	5	0	0	9	13	106	0	0	119	22	3	9	0	34	242
Total Volume	2	237	82	0	321	9	55	2	0	66	56	390	0	0	446	71	13	22	0	106	939
% App. Total	0.6	73.8	25.5	0		13.6	83.3	3	0		12.6	87.4	0	0		67	12.3	20.8	0		
PHF	.250	.884	.759	.000	.912	.563	.625	.500	.000	.688	.583	.920	.000	.000	.914	.807	.650	.611	.000	.779	.924

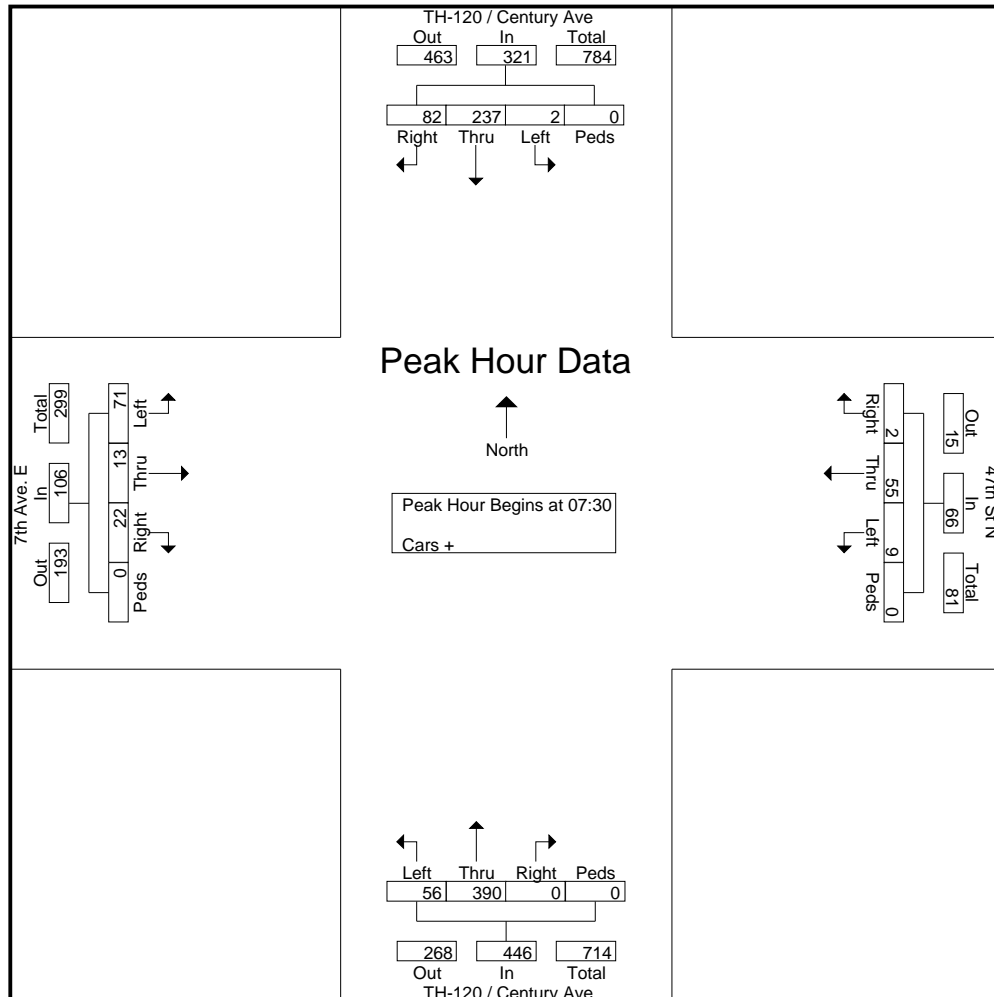



MINNESOTA DEPT OF TRANSPORTATION

TRAFFIC DATA COLLECTION - METRO

TH-120 at 7th Ave E / 47th St N
 Ref.Pt.: 006.883
 Data by: J\MR
 TURN MOVEMENT COUNT

File Name : TH 120 at 7th Ave E-47th St N 2013
 Site Code :
 Start Date : 4/3/2013
 Page No : 3

Start Time	TH-120 / Century Ave Southbound					47th St N Westbound					TH-120 / Century Ave Northbound					7th Ave. E Eastbound					Int. Total
	Left	Thru	Right	Peds	App. Total	Left	Thru	Right	Peds	App. Total	Left	Thru	Right	Peds	App. Total	Left	Thru	Right	Peds	App. Total	
Peak Hour Analysis From 15:00 to 17:30 - Peak 1 of 1																					
Peak Hour for Entire Intersection Begins at 16:30																					
16:30	1	131	27	0	159	2	7	3	0	12	12	78	2	0	92	28	12	13	0	53	316
16:45	0	123	19	0	142	1	6	0	0	7	12	97	1	0	110	56	16	15	0	87	346
17:00	6	120	25	0	151	2	11	2	0	15	16	82	1	0	99	49	12	13	0	74	339
17:15	1	107	38	0	146	3	7	1	0	11	6	92	3	0	101	41	10	12	0	63	321
Total Volume	8	481	109	0	598	8	31	6	0	45	46	349	7	0	402	174	50	53	0	277	1322
% App. Total	1.3	80.4	18.2	0		17.8	68.9	13.3	0		11.4	86.8	1.7	0		62.8	18.1	19.1	0		
PHF	.333	.918	.717	.000	.940	.667	.705	.500	.000	.750	.719	.899	.583	.000	.914	.777	.781	.883	.000	.796	.955

