



MINNESOTA DEPT OF TRANSPORTATION

TRAFFIC COLLECTION - METRO

Location: TH-120 AT 3M RD.
 REF.PT:002+00.421
 JAMAR#632\DR
 TURN MOVEMENT COUNT

File Name : TH 120 AT 3M RD 2006
 Site Code : 00000000
 Start Date : 8/23/2006
 Page No : 1

Groups Printed- Cars & Trucks

Start Time	TH 120 Southbound				3M RD Westbound				TH 120 Northbound				3M RD Eastbound				Int. Total
	Right	Thru	Left	Peds	Right	Thru	Left	Peds	Right	Thru	Left	Peds	Right	Thru	Left	Peds	
06:00	9	50	0	0	0	0	3	0	2	30	35	0	6	0	0	0	135
06:15	18	81	2	0	1	0	8	0	3	39	57	0	4	0	0	0	213
06:30	14	85	0	0	0	1	5	0	1	69	72	0	8	0	3	0	258
06:45	31	84	1	0	0	0	4	0	3	68	94	0	4	0	3	0	292
Total	72	300	3	0	1	1	20	0	9	206	258	0	22	0	6	0	898
07:00	26	92	0	0	1	3	6	0	1	95	114	0	6	1	0	0	345
07:15	36	98	3	0	3	1	3	0	0	120	125	0	11	1	0	0	401
07:30	49	96	2	0	3	3	3	0	2	140	139	0	12	0	3	0	452
07:45	47	108	1	0	2	2	6	0	2	169	163	0	11	2	4	0	517
Total	158	394	6	0	9	9	18	0	5	524	541	0	40	4	7	0	1715
08:00	49	90	2	0	3	1	4	0	7	135	167	0	12	1	6	0	477
08:15	31	84	3	0	3	3	2	0	6	130	113	0	5	0	3	0	383
08:30	20	69	0	0	2	0	7	0	5	84	92	0	8	0	2	0	289
08:45	18	88	6	0	3	1	2	0	1	110	87	0	7	0	2	0	325
Total	118	331	11	0	11	5	15	0	19	459	459	0	32	1	13	0	1474
15:00	5	115	4	0	5	0	3	0	6	80	9	0	130	0	32	0	389
15:15	3	140	1	0	2	0	3	0	1	114	11	0	88	1	32	0	396
15:30	0	143	1	0	5	1	5	0	4	108	10	0	112	2	26	0	417
15:45	5	154	3	0	2	0	5	0	4	98	12	0	111	2	29	0	425
Total	13	552	9	0	14	1	16	0	15	400	42	0	441	5	119	0	1627
16:00	2	156	5	0	3	0	4	0	7	122	6	0	216	0	43	0	564
16:15	2	180	3	0	0	0	2	0	4	139	4	0	313	1	61	0	709
16:30	3	204	4	0	3	1	3	0	2	147	6	0	394	5	72	0	844
16:45	3	207	1	0	3	0	1	0	2	130	6	0	369	3	90	0	815
Total	10	747	13	0	9	1	10	0	15	538	22	0	1292	9	266	0	2932
17:00	0	217	3	0	2	1	4	0	3	110	4	0	425	5	74	0	848
17:15	2	160	3	0	1	0	2	0	2	123	9	0	436	1	67	0	806
17:30	2	164	7	0	4	0	4	0	8	119	5	0	223	1	46	0	583
17:45	2	132	5	0	4	0	3	0	11	101	2	0	234	1	36	0	531
Total	6	673	18	0	11	1	13	0	24	453	20	0	1318	8	223	0	2768
Grand Total	377	2997	60	0	55	18	92	0	87	2580	1342	0	3145	27	634	0	11414
Apprch %	11	87.3	1.7	0	33.3	10.9	55.8	0	2.2	64.4	33.5	0	82.6	0.7	16.7	0	
Total %	3.3	26.3	0.5	0	0.5	0.2	0.8	0	0.8	22.6	11.8	0	27.6	0.2	5.6	0	



MINNESOTA DEPT OF TRANSPORTATION

TRAFFIC COLLECTION - METRO

File Name : TH 120 AT 3M RD 2006

Site Code : 00000000

Start Date : 8/23/2006

Page No : 2

Start Time	TH 120 Southbound					3M RD Westbound					TH 120 Northbound					3M RD Eastbound					Int. Total
	Right	Thru	Left	Peds	App. Total	Right	Thru	Left	Peds	App. Total	Right	Thru	Left	Peds	App. Total	Right	Thru	Left	Peds	App. Total	
Peak Hour Analysis From 06:00 to 08:45 - Peak 1 of 1																					
Peak Hour for Entire Intersection Begins at 07:15																					
07:15	36	98	3	0	137	3	1	3	0	7	0	120	125	0	245	11	1	0	0	12	401
07:30	49	96	2	0	147	3	3	3	0	9	2	140	139	0	281	12	0	3	0	15	452
07:45	47	108	1	0	156	2	2	6	0	10	2	169	163	0	334	11	2	4	0	17	517
08:00	49	90	2	0	141	3	1	4	0	8	7	135	167	0	309	12	1	6	0	19	477
Total Volume	181	392	8	0	581	11	7	16	0	34	11	564	594	0	1169	46	4	13	0	63	1847
% App. Total	31.2	67.5	1.4	0		32.4	20.6	47.1	0		0.9	48.2	50.8	0		73	6.3	20.6	0		
PHF	.923	.907	.667	.000	.931	.917	.583	.667	.000	.850	.393	.834	.889	.000	.875	.958	.500	.542	.000	.829	.893

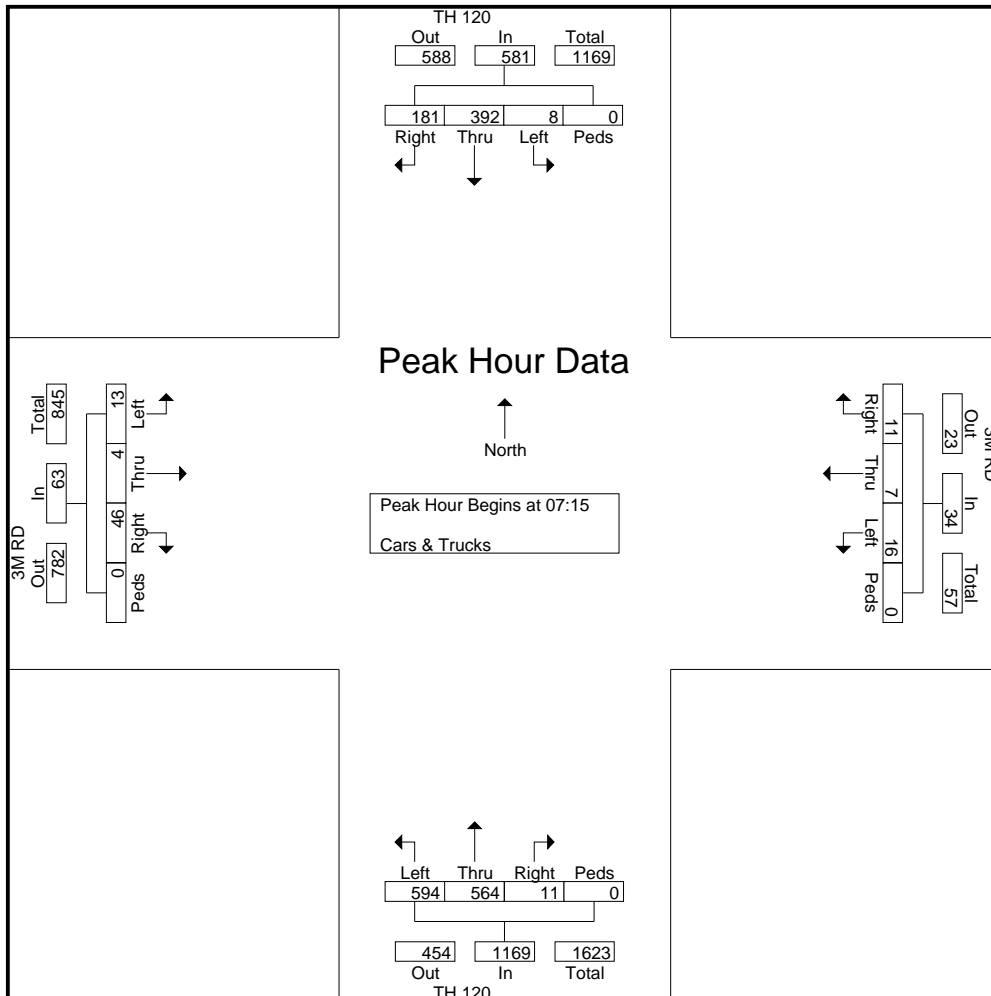



MINNESOTA DEPT OF TRANSPORTATION

TRAFFIC COLLECTION - METRO

File Name : TH 120 AT 3M RD 2006

Site Code : 00000000

Start Date : 8/23/2006

Page No : 3

Start Time	TH 120 Southbound					3M RD Westbound					TH 120 Northbound					3M RD Eastbound					Int. Total
	Right	Thru	Left	Peds	App. Total	Right	Thru	Left	Peds	App. Total	Right	Thru	Left	Peds	App. Total	Right	Thru	Left	Peds	App. Total	
16:30	3	204	4	0	211	3	1	3	0	7	2	147	6	0	155	394	5	72	0	471	844
16:45	3	207	1	0	211	3	0	1	0	4	2	130	6	0	138	369	3	90	0	462	815
17:00	0	217	3	0	220	2	1	4	0	7	3	110	4	0	117	425	5	74	0	504	848
17:15	2	160	3	0	165	1	0	2	0	3	2	123	9	0	134	436	1	67	0	504	806
Total Volume	8	788	11	0	807	9	2	10	0	21	9	510	25	0	544	1624	14	303	0	1941	3313
% App. Total	1	97.6	1.4	0		42.9	9.5	47.6	0		1.7	93.8	4.6	0		83.7	0.7	15.6	0		
PHF	.667	.908	.688	.000	.917	.750	.500	.625	.000	.750	.750	.867	.694	.000	.877	.931	.700	.842	.000	.963	.977

Peak Hour Analysis From 15:00 to 17:45 - Peak 1 of 1
 Peak Hour for Entire Intersection Begins at 16:30

