

Short Elliott Hendrickson Inc.

3535 Vadnais Center Drive
St. Paul, MN 55110

"Building a Better World for All of Us"



TRAFFIC DATA

I-94 & TH 95 (Manning Ave) S Ramp

Ref.Pt.: 254.810

Data By: Short Elliott Hendrickson, Inc.

TURN MOVEMENT COUNT

File Name : I-94 & TH 95 (Manning Ave) S Ramp 2019

Site Code : 7b

Start Date : 4/30/2019

Page No : 1

Groups Printed- Vehicles - Trucks

Start Time	TH 95 (Manning Ave) Southbound					I-94 Eastbound Ramp Westbound					TH 95 (Manning Ave) Northbound					I-94 Eastbound Ramp Eastbound					Int. Total
	Left	Thru	Right	Peds	App. Total	Left	Thru	Right	Peds	App. Total	Left	Thru	Right	Peds	App. Total	Left	Thru	Right	Peds	App. Total	
06:00	10	43	0	0	53	0	0	0	0	0	0	90	19	0	109	25	0	9	0	34	196
06:15	8	72	0	0	80	0	0	0	0	0	0	96	26	0	122	28	0	19	0	47	249
06:30	11	117	0	0	128	0	0	0	0	0	0	121	41	0	162	44	0	20	0	64	354
06:45	10	94	0	0	104	0	0	0	0	0	0	149	26	0	175	65	0	26	0	91	370
Total	39	326	0	0	365	0	0	0	0	0	0	456	112	0	568	162	0	74	0	236	1169
07:00	10	111	0	0	121	0	0	0	0	0	0	165	43	0	208	48	0	24	0	72	401
07:15	20	145	0	0	165	0	0	0	0	0	0	184	53	0	237	68	0	22	0	90	492
07:30	24	153	0	0	177	0	0	0	0	0	0	183	68	0	251	61	0	21	0	82	510
07:45	22	156	0	0	178	0	0	0	0	0	0	138	51	0	189	77	0	35	0	112	479
Total	76	565	0	0	641	0	0	0	0	0	0	670	215	0	885	254	0	102	0	356	1882
08:00	13	73	0	0	86	0	0	0	0	0	0	115	41	0	156	37	0	20	0	57	299
08:15	14	85	0	0	99	0	0	0	0	0	0	115	41	0	156	51	1	26	0	78	333
08:30	17	85	0	0	102	0	0	0	0	0	0	130	35	0	165	42	0	16	0	58	325
08:45	15	84	0	0	99	0	0	0	0	0	0	90	47	0	137	36	0	25	0	61	297
Total	59	327	0	0	386	0	0	0	0	0	0	450	164	0	614	166	1	87	0	254	1254
09:00	16	72	0	0	88	0	0	0	0	0	0	93	28	0	121	45	1	14	0	60	269
09:15	7	68	0	0	75	0	0	0	0	0	0	77	33	0	110	35	0	21	0	56	241
09:30	15	64	0	0	79	0	0	0	0	0	0	72	36	0	108	33	0	22	0	55	242
09:45	12	74	0	0	86	0	0	0	0	0	0	68	31	0	99	25	0	30	0	55	240
Total	50	278	0	0	328	0	0	0	0	0	0	310	128	0	438	138	1	87	0	226	992
10:00	12	62	0	0	74	0	0	0	0	0	0	60	19	0	79	29	1	24	0	54	207
10:15	9	53	0	0	62	0	0	0	0	0	0	63	25	0	88	27	0	19	0	46	196
10:30	17	53	0	0	70	0	0	0	0	0	0	69	28	0	97	47	3	21	0	71	238
10:45	20	63	0	0	83	0	0	0	0	0	0	73	17	0	90	26	0	20	0	46	219
Total	58	231	0	0	289	0	0	0	0	0	0	265	89	0	354	129	4	84	0	217	860
11:00	7	53	0	0	60	0	0	0	0	0	0	75	19	0	94	51	0	17	0	68	222
11:15	10	69	0	0	79	0	0	0	0	0	0	68	17	0	85	59	1	20	0	80	244
11:30	13	92	0	0	105	0	0	0	0	0	0	59	21	0	80	50	0	20	0	70	255
11:45	23	52	0	0	75	0	0	0	0	0	0	49	35	0	84	53	1	24	0	78	237
Total	53	266	0	0	319	0	0	0	0	0	0	251	92	0	343	213	2	81	0	296	958
12:00	19	59	0	0	78	0	0	0	0	0	0	71	30	0	101	49	1	26	0	76	255
12:15	8	79	0	0	87	0	0	0	0	0	0	60	22	0	82	50	1	32	0	83	252
12:30	18	49	0	0	67	0	0	0	0	0	0	70	32	0	102	47	0	15	0	62	231
12:45	16	60	0	0	76	0	0	0	0	0	0	66	35	0	101	66	0	29	0	95	272
Total	61	247	0	0	308	0	0	0	0	0	0	267	119	0	386	212	2	102	0	316	1010
13:00	16	62	0	0	78	0	0	0	0	0	0	49	21	0	70	61	1	30	0	92	240
13:15	12	69	0	0	81	0	0	0	0	0	0	65	22	0	87	54	0	25	0	79	247
13:30	21	60	0	0	81	0	0	0	0	0	0	70	32	0	102	54	3	33	0	90	273
13:45	21	71	0	0	92	0	0	0	0	0	0	62	36	0	98	41	0	29	0	70	260
Total	70	262	0	0	332	0	0	0	0	0	0	246	111	0	357	210	4	117	0	331	1020

Short Elliott Hendrickson Inc.

3535 Vadnais Center Drive
St. Paul, MN 55110

"Building a Better World for All of Us"



TRAFFIC DATA

I-94 & TH 95 (Manning Ave) S Ramp

Ref.Pt.: 254.810

Data By: Short Elliott Hendrickson, Inc.

TURN MOVEMENT COUNT

File Name : I-94 & TH 95 (Manning Ave) S Ramp 2019

Site Code : 7b

Start Date : 4/30/2019

Page No : 2

Groups Printed- Vehicles - Trucks

Start Time	TH 95 (Manning Ave) Southbound					I-94 Eastbound Ramp Westbound					TH 95 (Manning Ave) Northbound					I-94 Eastbound Ramp Eastbound					Int. Total
	Left	Thru	Right	Peds	App. Total	Left	Thru	Right	Peds	App. Total	Left	Thru	Right	Peds	App. Total	Left	Thru	Right	Peds	App. Total	
14:00	16	80	0	0	96	0	0	0	0	0	0	69	23	0	92	59	0	34	0	93	281
14:15	26	108	0	0	134	0	0	0	0	0	0	74	38	0	112	67	0	27	0	94	340
14:30	23	105	0	0	128	0	0	0	0	0	0	86	25	0	111	78	0	33	1	112	351
14:45	23	117	0	0	140	0	0	0	0	0	0	74	35	0	109	57	2	45	0	104	353
Total	88	410	0	0	498	0	0	0	0	0	0	303	121	0	424	261	2	139	1	403	1325
15:00	32	102	0	0	134	0	0	0	0	0	0	73	45	0	118	86	0	41	0	127	379
15:15	31	87	0	0	118	0	0	0	0	0	0	81	55	0	136	86	0	58	0	144	398
15:30	34	120	0	0	154	0	0	0	0	0	0	114	66	0	180	106	0	45	0	151	485
15:45	38	97	0	0	135	0	0	0	0	0	0	90	76	0	166	109	0	44	0	153	454
Total	135	406	0	0	541	0	0	0	0	0	0	358	242	0	600	387	0	188	0	575	1716
16:00	34	107	0	0	141	0	0	0	0	0	0	108	81	0	189	133	0	43	0	176	506
16:15	42	142	0	0	184	0	0	0	0	0	0	83	69	0	152	112	1	41	0	154	490
16:30	51	112	0	0	163	0	0	0	0	0	0	105	76	0	181	118	0	56	0	174	518
16:45	38	120	0	0	158	0	0	0	0	0	0	118	90	0	208	116	0	45	0	161	527
Total	165	481	0	0	646	0	0	0	0	0	0	414	316	0	730	479	1	185	0	665	2041
17:00	58	140	0	0	198	0	0	0	0	0	0	97	70	0	167	106	1	57	0	164	529
17:15	58	142	0	0	200	0	0	0	0	0	0	89	53	0	142	100	0	58	0	158	500
17:30	32	118	0	0	150	0	0	0	0	0	0	102	73	0	175	113	0	71	0	184	509
17:45	39	107	0	0	146	0	0	0	0	0	0	81	51	0	132	100	0	51	0	151	429
Total	187	507	0	0	694	0	0	0	0	0	0	369	247	0	616	419	1	237	0	657	1967
18:00	25	82	0	0	107	0	0	0	0	0	0	96	53	0	149	95	0	55	0	150	406
18:15	24	81	0	0	105	0	0	0	0	0	0	83	47	0	130	93	0	62	0	155	390
18:30	25	85	0	0	110	0	0	0	0	0	0	95	35	0	130	87	0	50	0	137	377
18:45	20	66	0	0	86	0	0	0	0	0	0	69	32	0	101	74	2	35	0	111	298
Total	94	314	0	0	408	0	0	0	0	0	0	343	167	0	510	349	2	202	0	553	1471
Grand Total	1135	4620	0	0	5755	0	0	0	0	0	0	4702	2123	0	6825	3379	20	1685	1	5085	17665
Apprch %	19.7	80.3	0	0		0	0	0	0	0	0	68.9	31.1	0		66.5	0.4	33.1	0		
Total %	6.4	26.2	0	0	32.6	0	0	0	0	0	0	26.6	12	0	38.6	19.1	0.1	9.5	0	28.8	
Vehicles	1097	4445										4488	2029			3311		1578			16964
% Vehicles	96.7	96.2	0	0	96.3	0	0	0	0	0	0	95.4	95.6	0	95.5	98	80	93.6	0	96.5	96
Trucks	38	175	0	0	213	0	0	0	0	0	0	214	94	0	308	68	4	107	1	180	701
% Trucks	3.3	3.8	0	0	3.7	0	0	0	0	0	0	4.6	4.4	0	4.5	2	20	6.4	100	3.5	4

Short Elliott Hendrickson Inc.

3535 Vadnais Center Drive
St. Paul, MN 55110

"Building a Better World for All of Us"



TRAFFIC DATA

I-94 & TH 95 (Manning Ave) S Ramp

Ref.Pt.: 254.810

Data By: Short Elliott Hendrickson, Inc.

TURN MOVEMENT COUNT

File Name : I-94 & TH 95 (Manning Ave) S Ramp 2019

Site Code : 7b

Start Date : 4/30/2019

Page No : 3

Start Time	TH 95 (Manning Ave) Southbound					I-94 Eastbound Ramp Westbound					TH 95 (Manning Ave) Northbound					I-94 Eastbound Ramp Eastbound					Int. Total
	Left	Thru	Right	Peds	App. Total	Left	Thru	Right	Peds	App. Total	Left	Thru	Right	Peds	App. Total	Left	Thru	Right	Peds	App. Total	
Peak Hour Analysis From 06:00 to 08:45 - Peak 1 of 1																					
Peak Hour for Entire Intersection Begins at 07:00																					
07:00	10	111	0	0	121	0	0	0	0	0	0	165	43	0	208	48	0	24	0	72	401
07:15	20	145	0	0	165	0	0	0	0	0	0	184	53	0	237	68	0	22	0	90	492
07:30	24	153	0	0	177	0	0	0	0	0	0	183	68	0	251	61	0	21	0	82	510
07:45	22	156	0	0	178	0	0	0	0	0	0	138	51	0	189	77	0	35	0	112	479
Total Volume	76	565	0	0	641	0	0	0	0	0	0	670	215	0	885	254	0	102	0	356	1882
% App. Total	11.9	88.1	0	0		0	0	0	0		0	75.7	24.3	0		71.3	0	28.7	0		
PHF	.792	.905	.000	.000	.900	.000	.000	.000	.000	.000	.000	.910	.790	.000	.881	.825	.000	.729	.000	.795	.923

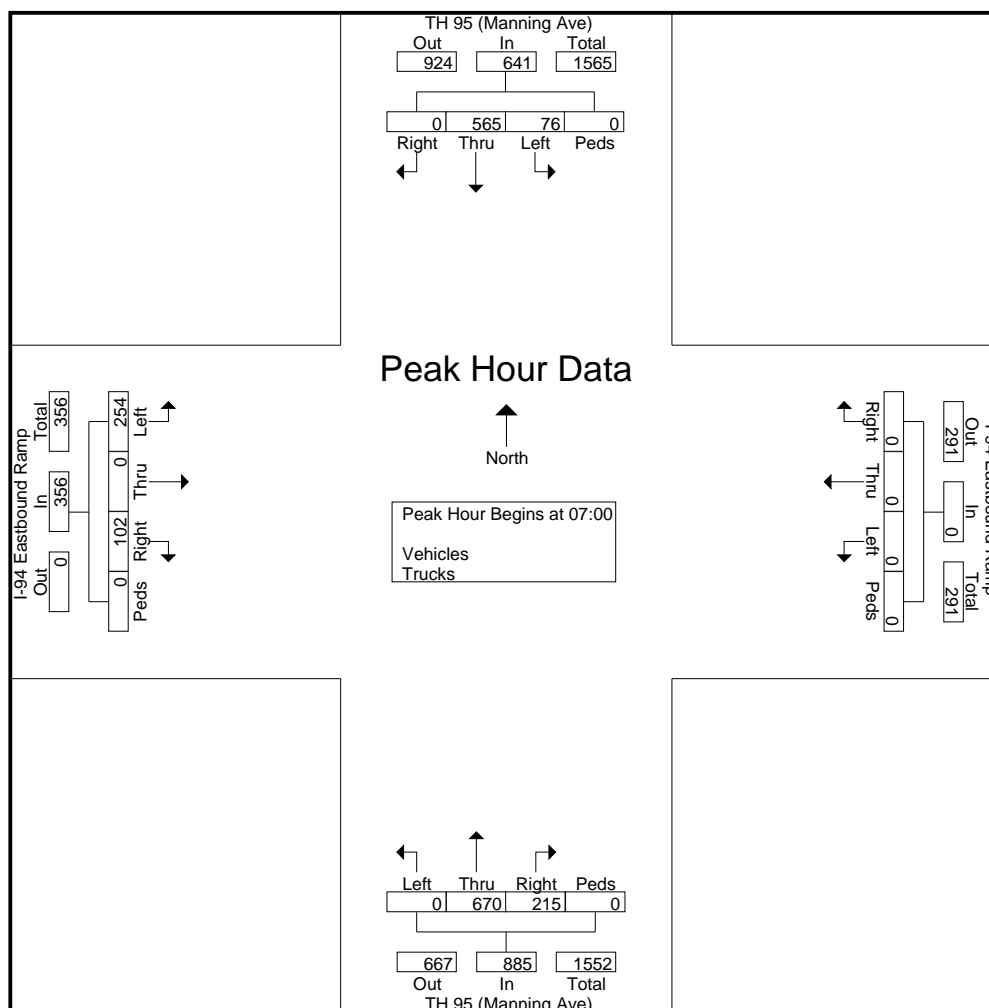

Short Elliott Hendrickson Inc.

3535 Vadnais Center Drive
St. Paul, MN 55110

"Building a Better World for All of Us"



TRAFFIC DATA

I-94 & TH 95 (Manning Ave) S Ramp

Ref.Pt.: 254.810

Data By: Short Elliott Hendrickson, Inc.

TURN MOVEMENT COUNT

File Name : I-94 & TH 95 (Manning Ave) S Ramp 2019

Site Code : 7b

Start Date : 4/30/2019

Page No : 4

Start Time	TH 95 (Manning Ave) Southbound					I-94 Eastbound Ramp Westbound					TH 95 (Manning Ave) Northbound					I-94 Eastbound Ramp Eastbound					Int. Total
	Left	Thru	Right	Peds	App. Total	Left	Thru	Right	Peds	App. Total	Left	Thru	Right	Peds	App. Total	Left	Thru	Right	Peds	App. Total	
Peak Hour Analysis From 11:00 to 12:45 - Peak 1 of 1 Peak Hour for Entire Intersection Begins at 12:00																					
12:00	19	59	0	0	78	0	0	0	0	0	0	71	30	0	101	49	1	26	0	76	255
12:15	8	79	0	0	87	0	0	0	0	0	0	60	22	0	82	50	1	32	0	83	252
12:30	18	49	0	0	67	0	0	0	0	0	0	70	32	0	102	47	0	15	0	62	231
12:45	16	60	0	0	76	0	0	0	0	0	0	66	35	0	101	66	0	29	0	95	272
Total Volume	61	247	0	0	308	0	0	0	0	0	0	267	119	0	386	212	2	102	0	316	1010
% App. Total	19.8	80.2	0	0		0	0	0	0		0	69.2	30.8	0		67.1	0.6	32.3	0		
PHF	.803	.782	.000	.000	.885	.000	.000	.000	.000	.000	.000	.940	.850	.000	.946	.803	.500	.797	.000	.832	.928

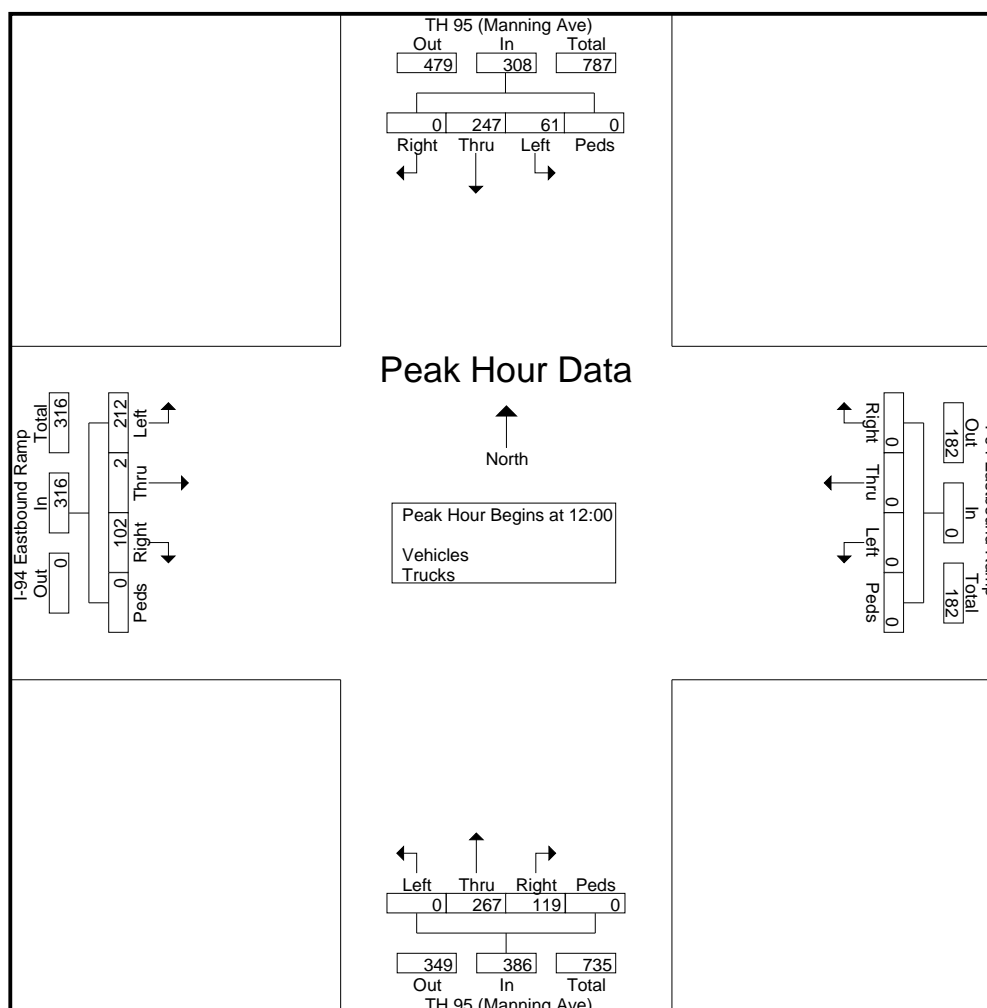

Short Elliott Hendrickson Inc.

3535 Vadnais Center Drive
St. Paul, MN 55110

"Building a Better World for All of Us"



TRAFFIC DATA

I-94 & TH 95 (Manning Ave) S Ramp

Ref.Pt.: 254.810

Data By: Short Elliott Hendrickson, Inc.

TURN MOVEMENT COUNT

File Name : I-94 & TH 95 (Manning Ave) S Ramp 2019

Site Code : 7b

Start Date : 4/30/2019

Page No : 5

Start Time	TH 95 (Manning Ave) Southbound					I-94 Eastbound Ramp Westbound					TH 95 (Manning Ave) Northbound					I-94 Eastbound Ramp Eastbound					Int. Total
	Left	Thru	Right	Peds	App. Total	Left	Thru	Right	Peds	App. Total	Left	Thru	Right	Peds	App. Total	Left	Thru	Right	Peds	App. Total	
Peak Hour Analysis From 15:00 to 17:45 - Peak 1 of 1 Peak Hour for Entire Intersection Begins at 16:30																					
16:30	51	112	0	0	163	0	0	0	0	0	0	105	76	0	181	118	0	56	0	174	518
16:45	38	120	0	0	158	0	0	0	0	0	0	118	90	0	208	116	0	45	0	161	527
17:00	58	140	0	0	198	0	0	0	0	0	0	97	70	0	167	106	1	57	0	164	529
17:15	58	142	0	0	200	0	0	0	0	0	0	89	53	0	142	100	0	58	0	158	500
Total Volume	205	514	0	0	719	0	0	0	0	0	0	409	289	0	698	440	1	216	0	657	2074
% App. Total	28.5	71.5	0	0		0	0	0	0		0	58.6	41.4	0		67	0.2	32.9	0		
PHF	.884	.905	.000	.000	.899	.000	.000	.000	.000	.000	.000	.867	.803	.000	.839	.932	.250	.931	.000	.944	.980

