



Minnesota Dept. of Transportation

Traffic Data Collection -Metro

CONCORDIA AVE AT PASCAL ST
 Ref.Pt;
 Jamar # T-2638 CAH
 TURN MOVEMENT COUNT

File Name : CONCORDIA AVE AT PASCAL ST
 Site Code : 00000000
 Start Date : 9/19/2012
 Page No : 1

Groups Printed- Unshifted

Start Time	PASCAL ST Southbound				CONCORDIA AVE Westbound				PASCAL ST Northbound				CONCORDIA AVE Eastbound				Int. Total
	Right	Thru	Left	Peds	Right	Thru	Left	Peds	Right	Thru	Left	Peds	Right	Thru	Left	Peds	
06:00	0	6	4	0	0	0	0	0	3	7	0	0	1	10	14	0	45
06:15	0	10	5	0	0	0	0	0	4	8	0	0	3	13	19	0	62
06:30	0	9	3	0	0	0	0	0	1	5	0	1	5	19	24	1	68
06:45	0	8	13	2	0	0	0	0	1	9	0	1	3	19	11	1	68
Total	0	33	25	2	0	0	0	0	9	29	0	2	12	61	68	2	243
07:00	0	16	15	2	0	0	0	0	6	12	0	1	7	30	10	1	100
07:15	0	5	9	0	0	0	0	0	2	9	0	1	5	13	4	1	49
07:30	0	24	15	2	0	2	0	0	10	14	0	0	9	58	10	1	145
07:45	0	10	18	4	0	0	0	0	7	13	0	0	9	62	13	3	139
Total	0	55	57	8	0	2	0	0	25	48	0	2	30	163	37	6	433
08:00	0	14	18	0	0	0	0	0	8	14	0	0	6	47	8	0	115
08:15	0	15	11	0	0	0	0	0	8	17	0	1	1	56	8	2	119
08:30	0	9	23	1	0	0	0	0	9	10	0	3	0	37	6	0	98
08:45	0	14	29	2	0	0	0	1	8	12	0	2	5	52	20	0	145
Total	0	52	81	3	0	0	0	1	33	53	0	6	12	192	42	2	477
*** BREAK ***																	
15:00	0	28	52	4	0	0	0	1	18	23	0	0	8	61	20	1	216
15:15	1	35	53	2	0	0	0	0	22	22	0	1	10	96	23	0	265
15:30	1	42	37	6	0	0	0	0	23	23	0	5	6	87	28	3	261
15:45	0	41	58	4	0	0	0	1	14	24	0	4	10	105	27	3	291
Total	2	146	200	16	0	0	0	2	77	92	0	10	34	349	98	7	1033
16:00	0	50	51	1	0	0	0	0	14	24	0	1	11	111	17	0	280
16:15	0	43	52	5	0	0	0	0	18	34	0	0	15	97	23	1	288
16:30	0	41	49	2	0	0	0	0	16	32	0	1	8	113	23	0	285
16:45	0	39	60	1	0	0	0	0	13	21	0	2	7	121	24	0	288
Total	0	173	212	9	0	0	0	0	61	111	0	4	41	442	87	1	1141
17:00	0	43	56	1	0	0	0	0	11	38	0	4	14	126	13	2	308
17:15	0	48	49	0	0	0	0	0	13	34	0	5	16	133	27	3	328
17:30	0	40	56	3	0	0	0	0	15	35	0	3	10	107	27	2	298
17:45	0	37	52	1	0	0	0	0	7	29	0	1	10	97	22	3	259
Total	0	168	213	5	0	0	0	0	46	136	0	13	50	463	89	10	1193
Grand Total	2	627	788	43	0	2	0	3	251	469	0	37	179	1670	421	28	4520
Apprch %	0.1	42.9	54	2.9	0	40	0	60	33.2	62	0	4.9	7.8	72.7	18.3	1.2	
Total %	0	13.9	17.4	1	0	0	0	0.1	5.6	10.4	0	0.8	4	36.9	9.3	0.6	



Minnesota Dept. of Transportation

Traffic Data Collection -Metro

CONCORDIA AVE AT PASCAL ST
 Ref.Pt;
 Jamar # T-2638 CAH
 TURN MOVEMENT COUNT

File Name : CONCORDIA AVE AT PASCAL ST
 Site Code : 00000000
 Start Date : 9/19/2012
 Page No : 2

Start Time	PASCAL ST Southbound					CONCORDIA AVE Westbound					PASCAL ST Northbound					CONCORDIA AVE Eastbound					Int. Total
	Right	Thru	Left	Peds	App. Total	Right	Thru	Left	Peds	App. Total	Right	Thru	Left	Peds	App. Total	Right	Thru	Left	Peds	App. Total	
Peak Hour Analysis From 06:00 to 08:45 - Peak 1 of 1																					
Peak Hour for Entire Intersection Begins at 07:30																					
07:30	0	24	15	2	41	0	2	0	0	2	10	14	0	0	24	9	58	10	1	78	145
07:45	0	10	18	4	32	0	0	0	0	0	7	13	0	0	20	9	62	13	3	87	139
08:00	0	14	18	0	32	0	0	0	0	0	8	14	0	0	22	6	47	8	0	61	115
08:15	0	15	11	0	26	0	0	0	0	0	8	17	0	1	26	1	56	8	2	67	119
Total Volume	0	63	62	6	131	0	2	0	0	2	33	58	0	1	92	25	223	39	6	293	518
% App. Total	0	48.1	47.3	4.6		0	100	0	0		35.9	63	0	1.1		8.5	76.1	13.3	2		
PHF	.000	.656	.861	.375	.799	.000	.250	.000	.000	.250	.825	.853	.000	.250	.885	.694	.899	.750	.500	.842	.893

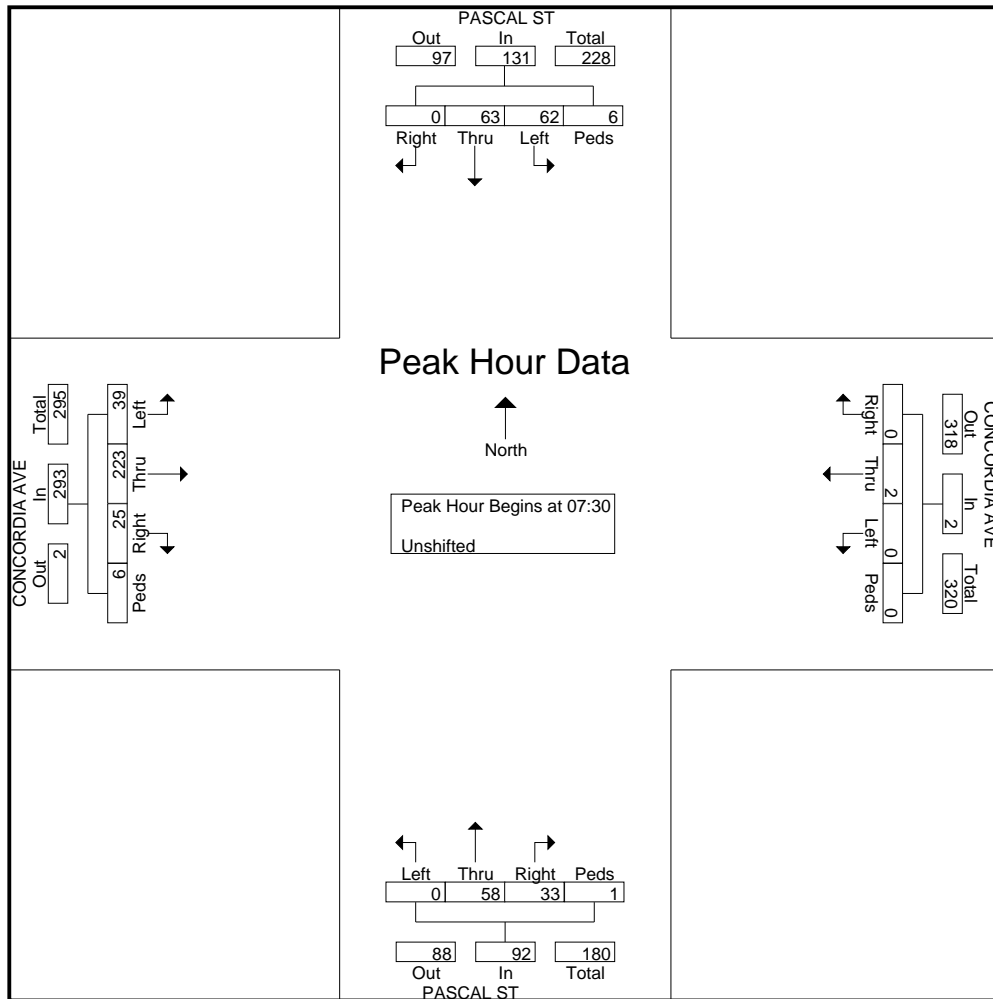



Minnesota Dept. of Transportation

Traffic Data Collection -Metro

CONCORDIA AVE AT PASCAL ST
 Ref.Pt;
 Jamar # T-2638 CAH
 TURN MOVEMENT COUNT

File Name : CONCORDIA AVE AT PASCAL ST
 Site Code : 00000000
 Start Date : 9/19/2012
 Page No : 3

Start Time	PASCAL ST Southbound					CONCORDIA AVE Westbound					PASCAL ST Northbound					CONCORDIA AVE Eastbound					Int. Total
	Rig ht	Thr u	Left	Ped s	App. Total	Rig ht	Thr u	Left	Ped s	App. Total	Right	Thr u	Left	Peds	App. Total	Right	Thr u	Left	Peds	App. Total	
Peak Hour Analysis From 15:00 to 17:45 - Peak 1 of 1																					
Peak Hour for Entire Intersection Begins at 16:45																					
16:45	0	39	60	1	100	0	0	0	0	0	13	21	0	2	36	7	121	24	0	152	288
17:00	0	43	56	1	100	0	0	0	0	0	11	38	0	4	53	14	126	13	2	155	308
17:15	0	48	49	0	97	0	0	0	0	0	13	34	0	5	52	16	133	27	3	179	328
17:30	0	40	56	3	99	0	0	0	0	0	15	35	0	3	53	10	107	27	2	146	298
Total Volume	0	170	221	5	396	0	0	0	0	0	52	128	0	14	194	47	487	91	7	632	1222
% App. Total	0	42.9	55.8	1.3		0	0	0	0		26.8	66	0	7.2		7.4	77.1	14.4	1.1		
PHF	.000	.885	.921	.417	.990	.000	.000	.000	.000	.000	.867	.842	.000	.700	.915	.734	.915	.843	.583	.883	.931

