



# MINNESOTA DEPT OF TRANSPORTATION

## TRAFFIC DATA COLLECTION - METRO

I-494 at 12th Ave., South Ramps  
 Ref.Pt.: 003.350  
 JAMAR # T-2638 CAH  
 TURN MOVEMENT COUNT

File Name : I-494 at 12th Ave south ramps 2010  
 Site Code : 00000000  
 Start Date : 10/5/2010  
 Page No : 1

### Groups Printed- Cars & Trucks

Start Time	12th Ave. Southbound				ramp to EB I-494 Westbound				12th Ave. Northbound				ramp from EB I-494 Eastbound				Int. Total
	Left	Thru	Right	Peds	Left	Thru	Right	Peds	Left	Thru	Right	Peds	Left	Thru	Right	Peds	
06:00	30	29	0	0	0	0	0	0	0	26	35	1	1	22	0	0	144
06:15	28	29	0	2	0	0	0	0	0	22	24	0	6	19	8	0	138
06:30	51	40	0	5	0	0	0	0	0	31	47	1	6	22	3	0	206
06:45	53	49	0	1	0	0	0	0	0	23	34	0	7	48	8	1	224
Total	162	147	0	8	0	0	0	0	0	102	140	2	20	111	19	1	712
07:00	44	57	0	2	0	0	0	0	1	36	42	0	8	39	4	0	233
07:15	49	73	0	11	0	0	0	0	0	51	37	0	9	42	8	2	282
07:30	55	77	1	5	0	0	0	0	0	59	54	0	8	56	12	2	329
07:45	42	98	0	3	0	0	0	0	0	82	51	1	10	52	33	0	372
Total	190	305	1	21	0	0	0	0	1	228	184	1	35	189	57	4	1216
08:00	31	113	0	3	0	0	0	1	0	53	45	1	4	59	12	0	322
08:15	34	95	0	2	0	0	0	0	0	66	27	0	8	53	13	1	299
08:30	49	79	0	4	0	0	0	0	0	53	56	0	16	60	18	2	337
08:45	47	115	0	2	0	0	0	0	0	48	27	0	12	58	11	0	320
Total	161	402	0	11	0	0	0	1	0	220	155	1	40	230	54	3	1278
*** BREAK ***																	
15:00	41	82	0	12	0	0	0	1	0	62	54	1	19	61	30	2	365
15:15	63	87	0	11	0	0	0	0	0	55	66	2	12	58	15	2	371
15:30	53	79	0	5	0	0	0	0	0	67	96	1	23	71	9	0	404
15:45	65	110	0	10	0	0	0	0	0	42	71	0	26	62	13	0	399
Total	222	358	0	38	0	0	0	1	0	226	287	4	80	252	67	4	1539
16:00	67	91	0	3	0	0	0	1	0	79	73	3	29	105	14	0	465
16:15	53	99	0	5	0	0	0	0	0	73	88	0	25	90	12	1	446
16:30	83	90	0	16	0	0	0	0	0	80	105	0	21	103	12	2	512
16:45	84	81	0	8	0	0	0	0	0	69	104	3	18	95	9	1	472
Total	287	361	0	32	0	0	0	1	0	301	370	6	93	393	47	4	1895
17:00	71	111	0	8	0	0	0	0	0	97	128	1	18	135	5	2	576
17:15	79	110	0	3	0	0	0	0	0	70	90	1	28	109	9	0	499
17:30	67	115	0	9	0	0	0	0	0	78	91	3	12	91	10	0	476
17:45	62	94	0	8	0	0	0	0	0	72	69	1	24	85	3	2	420
Total	279	430	0	28	0	0	0	0	0	317	378	6	82	420	27	4	1971
Grand Total	1301	2003	1	138	0	0	0	3	1	1394	1514	20	350	1595	271	20	8611
Apprch %	37.8	58.2	0	4	0	0	0	100	0	47.6	51.7	0.7	15.7	71.3	12.1	0.9	
Total %	15.1	23.3	0	1.6	0	0	0	0	0	16.2	17.6	0.2	4.1	18.5	3.1	0.2	



# MINNESOTA DEPT OF TRANSPORTATION

## TRAFFIC DATA COLLECTION - METRO

I-494 at 12th Ave., South Ramps  
 Ref.Pt.: 003.350  
 JAMAR # T-2638 CAH  
 TURN MOVEMENT COUNT

File Name : I-494 at 12th Ave south ramps 2010  
 Site Code : 00000000  
 Start Date : 10/5/2010  
 Page No : 2

Start Time	12th Ave. Southbound					ramp to EB I-494 Westbound					12th Ave. Northbound					ramp from EB I-494 Eastbound					Int. Total
	Left	Thru	Right	Peds	App. Total	Left	Thru	Right	Peds	App. Total	Left	Thru	Right	Peds	App. Total	Left	Thru	Right	Peds	App. Total	
Peak Hour Analysis From 06:00 to 08:45 - Peak 1 of 1																					
Peak Hour for Entire Intersection Begins at 07:45																					
07:45	42	98	0	3	143	0	0	0	0	0	0	82	51	1	134	10	52	33	0	95	372
08:00	31	113	0	3	147	0	0	0	1	1	0	53	45	1	99	4	59	12	0	75	322
08:15	34	95	0	2	131	0	0	0	0	0	0	66	27	0	93	8	53	13	1	75	299
08:30	49	79	0	4	132	0	0	0	0	0	0	53	56	0	109	16	60	18	2	96	337
Total Volume	156	385	0	12	553	0	0	0	1	1	0	254	179	2	435	38	224	76	3	341	1330
% App. Total	28.2	69.6	0	2.2		0	0	0	100		0	58.4	41.1	0.5		11.1	65.7	22.3	0.9		
PHF	.796	.852	.000	.750	.940	.000	.000	.000	.250	.250	.000	.774	.799	.500	.812	.594	.933	.576	.375	.888	.894

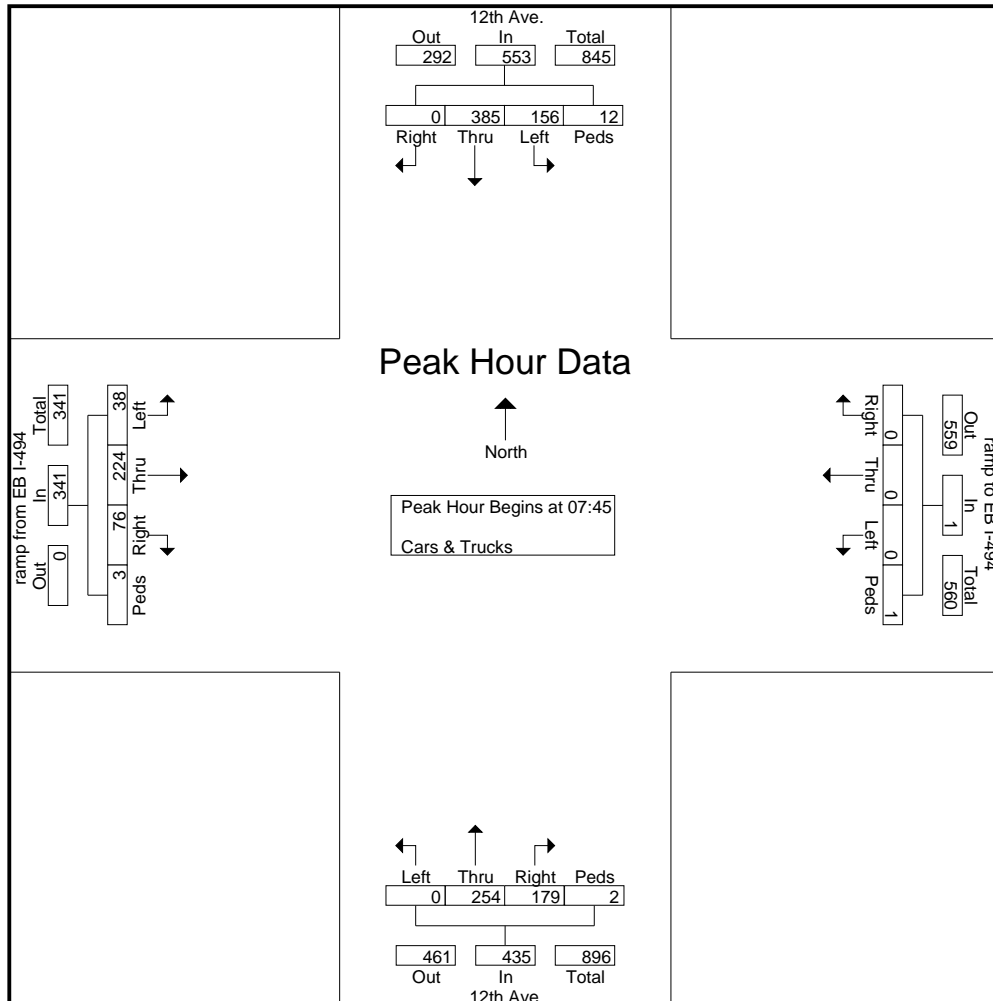



# MINNESOTA DEPT OF TRANSPORTATION

## TRAFFIC DATA COLLECTION - METRO

I-494 at 12th Ave., South Ramps  
 Ref.Pt.: 003.350  
 JAMAR # T-2638 CAH  
 TURN MOVEMENT COUNT

File Name : I-494 at 12th Ave south ramps 2010  
 Site Code : 00000000  
 Start Date : 10/5/2010  
 Page No : 3

Start Time	12th Ave. Southbound					ramp to EB I-494 Westbound					12th Ave. Northbound					ramp from EB I-494 Eastbound					Int. Total
	Left	Thru	Right	Peds	App. Total	Left	Thru	Right	Peds	App. Total	Left	Thru	Right	Peds	App. Total	Left	Thru	Right	Peds	App. Total	

Peak Hour Analysis From 15:00 to 17:45 - Peak 1 of 1  
 Peak Hour for Entire Intersection Begins at 16:30

16:30	83	90	0	16	189	0	0	0	0	0	0	80	105	0	185	21	103	12	2	138	512
16:45	84	81	0	8	173	0	0	0	0	0	0	69	104	3	176	18	95	9	1	123	472
17:00	71	111	0	8	190	0	0	0	0	0	0	97	128	1	226	18	135	5	2	160	576
17:15	79	110	0	3	192	0	0	0	0	0	0	70	90	1	161	28	109	9	0	146	499
Total Volume	317	392	0	35	744	0	0	0	0	0	0	316	427	5	748	85	442	35	5	567	2059
% App. Total	42.6	52.7	0	4.7		0	0	0	0		0	42.2	57.1	0.7		15	78	6.2	0.9		
PHF	.943	.883	.000	.547	.969	.000	.000	.000	.000	.000	.000	.814	.834	.417	.827	.759	.819	.729	.625	.886	.894

