



# MINNESOTA DEPT OF TRANSPORTATION

## TRAFFIC DATA COLLECTION - METRO

I-394 at Xenia Ave , North Ramps  
 Ref.Pt.: 005.413  
 video MD  
 TURN MOVEMENT COUNT

File Name : I-394 at Xenia Ave NORTH RAMPS 2014  
 Site Code :  
 Start Date : 2/4/2014  
 Page No : 1

Groups Printed- Cars +

Start Time	Xenia Ave Southbound				ramp from I-394 WB Westbound				Park Place Blvd Northbound				ramp to I-394 WB Eastbound				Int. Total
	Right	Thru	Left	Peds	Right	Thru	Left	Peds	Right	Thru	Left	Peds	Right	Thru	Left	Peds	
06:00	3	5	0	0	49	2	32	0	0	24	7	0	0	0	0	0	122
06:15	6	15	0	0	45	0	43	0	0	30	7	0	0	0	0	0	146
06:30	12	18	0	0	56	0	39	0	0	51	15	0	0	0	0	0	191
06:45	13	29	0	0	90	0	78	0	0	42	13	0	0	0	0	0	265
Total	34	67	0	0	240	2	192	0	0	147	42	0	0	0	0	0	724
07:00	16	47	0	0	122	0	97	0	0	62	20	0	0	0	0	0	364
07:15	18	69	0	0	138	0	122	0	0	60	24	0	0	0	0	0	431
07:30	30	74	0	0	131	1	112	0	0	92	36	0	0	0	0	0	476
07:45	26	60	0	0	139	0	140	0	0	120	47	0	0	0	0	0	532
Total	90	250	0	0	530	1	471	0	0	334	127	0	0	0	0	0	1803
08:00	38	87	0	0	139	0	115	0	0	137	35	0	0	0	0	0	551
08:15	27	113	0	0	148	1	140	0	0	128	45	0	0	0	0	0	602
08:30	34	95	0	0	165	0	141	0	0	99	33	0	0	0	0	0	567
08:45	43	70	0	0	136	1	119	0	0	86	37	0	0	0	0	0	492
Total	142	365	0	0	588	2	515	0	0	450	150	0	0	0	0	0	2212
***** BREAK *****																	
15:00	45	95	0	0	39	0	85	0	0	43	102	0	0	0	0	0	409
15:15	45	125	0	0	29	2	100	0	0	48	106	0	0	0	0	0	455
15:30	72	104	0	0	21	0	94	0	0	56	107	0	0	0	0	0	454
15:45	57	103	0	0	39	0	112	0	0	68	97	0	0	0	0	0	476
Total	219	427	0	0	128	2	391	0	0	215	412	0	0	0	0	0	1794
16:00	69	183	0	0	33	0	135	0	0	76	107	0	0	0	0	0	603
16:15	86	185	0	0	25	0	134	0	0	86	116	0	0	0	0	0	632
16:30	85	174	0	0	31	0	124	0	0	74	115	0	0	0	0	0	603
16:45	75	179	0	0	34	0	133	0	0	96	120	0	0	0	0	0	637
Total	315	721	0	0	123	0	526	0	0	332	458	0	0	0	0	0	2475
17:00	80	189	0	0	34	1	127	0	0	95	102	0	0	0	0	0	628
17:15	81	185	0	0	22	1	110	0	0	97	99	0	0	0	0	0	595
17:30	72	161	0	0	18	0	160	0	0	103	109	0	0	0	0	0	623
17:45	59	152	0	0	24	1	136	0	0	88	89	0	0	0	0	0	549
Total	292	687	0	0	98	3	533	0	0	383	399	0	0	0	0	0	2395
Grand Total	1092	2517	0	0	1707	10	2628	0	0	1861	1588	0	0	0	0	0	11403
Apprch %	30.3	69.7	0	0	39.3	0.2	60.5	0	0	54	46	0	0	0	0	0	
Total %	9.6	22.1	0	0	15	0.1	23	0	0	16.3	13.9	0	0	0	0	0	



# MINNESOTA DEPT OF TRANSPORTATION

## TRAFFIC DATA COLLECTION - METRO

I-394 at Xenia Ave , North Ramps  
 Ref.Pt.: 005.413  
 video MD  
 TURN MOVEMENT COUNT

File Name : I-394 at Xenia Ave NORTH RAMPS 2014  
 Site Code :  
 Start Date : 2/4/2014  
 Page No : 2

Start Time	Xenia Ave Southbound					ramp from I-394 WB Westbound					Park Place Blvd Northbound					ramp to I-394 WB Eastbound					Int. Total
	Right	Thru	Left	Peds	App. Total	Right	Thru	Left	Peds	App. Total	Right	Thru	Left	Peds	App. Total	Right	Thru	Left	Peds	App. Total	
Peak Hour Analysis From 06:00 to 08:45 - Peak 1 of 1																					
Peak Hour for Entire Intersection Begins at 07:45																					
07:45	26	60	0	0	86	139	0	140	0	279	0	120	47	0	167	0	0	0	0	0	532
08:00	38	87	0	0	125	139	0	115	0	254	0	137	35	0	172	0	0	0	0	0	551
08:15	27	113	0	0	140	148	1	140	0	289	0	128	45	0	173	0	0	0	0	0	602
08:30	34	95	0	0	129	165	0	141	0	306	0	99	33	0	132	0	0	0	0	0	567
Total Volume	125	355	0	0	480	591	1	536	0	1128	0	484	160	0	644	0	0	0	0	0	2252
% App. Total	26	74	0	0		52.4	0.1	47.5	0		0	75.2	24.8	0		0	0	0	0		
PHF	.822	.785	.000	.000	.857	.895	.250	.950	.000	.922	.000	.883	.851	.000	.931	.000	.000	.000	.000	.000	.935

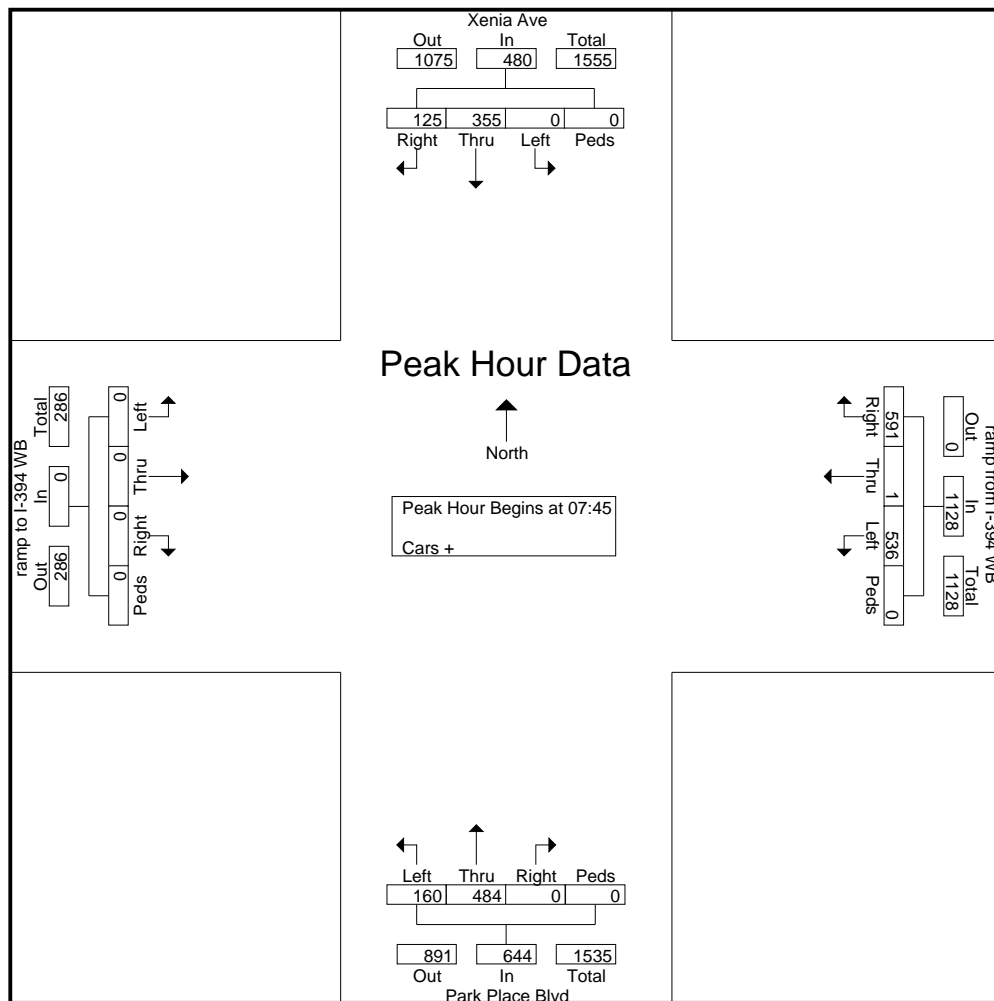



# MINNESOTA DEPT OF TRANSPORTATION

TRAFFIC DATA COLLECTION - METRO

I-394 at Xenia Ave , North Ramps  
 Ref.Pt.: 005.413  
 video MD  
 TURN MOVEMENT COUNT

File Name : I-394 at Xenia Ave NORTH RAMPS 2014  
 Site Code :  
 Start Date : 2/4/2014  
 Page No : 3

Start Time	Xenia Ave Southbound					ramp from I-394 WB Westbound					Park Place Blvd Northbound					ramp to I-394 WB Eastbound					Int. Total
	Rig ht	Thr u	Left	Ped s	App. Total	Rig ht	Thr u	Left	Ped s	App. Total	Right	Thr u	Left	Peds	App. Total	Right	Thr u	Left	Peds	App. Total	
16:15	86	185	0	0	271	25	0	134	0	159	0	86	116	0	202	0	0	0	0	0	632
16:30	85	174	0	0	259	31	0	124	0	155	0	74	115	0	189	0	0	0	0	0	603
16:45	75	179	0	0	254	34	0	133	0	167	0	96	120	0	216	0	0	0	0	0	637
17:00	80	189	0	0	269	34	1	127	0	162	0	95	102	0	197	0	0	0	0	0	628
Total Volume	326	727	0	0	1053	124	1	518	0	643	0	351	453	0	804	0	0	0	0	0	2500
% App. Total	31	69	0	0		19.3	0.2	80.6	0		0	43.7	56.3	0		0	0	0	0		
PHF	.948	.962	.000	.000	.971	.912	.250	.966	.000	.963	.000	.914	.944	.000	.931	.000	.000	.000	.000	.000	.981

Peak Hour Analysis From 15:00 to 17:45 - Peak 1 of 1  
 Peak Hour for Entire Intersection Begins at 16:15

