



MINNESOTA DEPT OF TRANSPORTATION

TRAFFIC DATA COLLECTION - METRO

I-35W at W 94th Street, east ramps

Ref.Pt.: 006.738

JAMAR # 631 BR/RE

TURN MOVEMENT COUNT

File Name : I-35W at W 94th St east ramps 2012

Site Code : 00000000

Start Date : 1/19/2012

Page No : 1

Groups Printed- Cars & Trucks

| Start Time | ramp to I-35W NB / frontage rd Southbound | | | | W 94th Street Westbound | | | | ramp from I-35W northbound Northbound | | | | W 94th Street Eastbound | | | | Int. Total |
|---------------|-------------------------------------------------|------|-------|------|----------------------------|------|-------|------|---------------------------------------------|------|-------|------|----------------------------|------|-------|------|------------|
| | Left | Thru | Right | Peds | Left | Thru | Right | Peds | Left | Thru | Right | Peds | Left | Thru | Right | Peds | |
| 06:00 | 0 | 0 | 0 | 0 | 0 | 8 | 5 | 0 | 16 | 0 | 16 | 0 | 17 | 18 | 0 | 0 | 80 |
| 06:15 | 0 | 0 | 0 | 0 | 0 | 20 | 15 | 0 | 19 | 1 | 22 | 0 | 21 | 30 | 0 | 0 | 128 |
| 06:30 | 0 | 0 | 0 | 0 | 0 | 16 | 22 | 0 | 34 | 1 | 30 | 0 | 27 | 31 | 0 | 0 | 161 |
| 06:45 | 0 | 0 | 0 | 0 | 0 | 38 | 17 | 0 | 42 | 5 | 28 | 0 | 35 | 41 | 0 | 0 | 206 |
| Total | 0 | 0 | 0 | 0 | 0 | 82 | 59 | 0 | 111 | 7 | 96 | 0 | 100 | 120 | 0 | 0 | 575 |
| 07:00 | 0 | 0 | 0 | 0 | 0 | 28 | 29 | 0 | 44 | 5 | 15 | 0 | 38 | 43 | 0 | 0 | 202 |
| 07:15 | 0 | 0 | 0 | 0 | 0 | 38 | 27 | 0 | 31 | 3 | 15 | 0 | 51 | 46 | 0 | 0 | 211 |
| 07:30 | 0 | 0 | 0 | 0 | 0 | 51 | 21 | 0 | 40 | 3 | 14 | 0 | 36 | 59 | 0 | 0 | 224 |
| 07:45 | 0 | 0 | 0 | 0 | 0 | 56 | 17 | 0 | 45 | 8 | 32 | 0 | 31 | 73 | 0 | 0 | 262 |
| Total | 0 | 0 | 0 | 0 | 0 | 173 | 94 | 0 | 160 | 19 | 76 | 0 | 156 | 221 | 0 | 0 | 899 |
| 08:00 | 0 | 0 | 0 | 0 | 0 | 64 | 27 | 0 | 49 | 3 | 21 | 0 | 31 | 47 | 0 | 0 | 242 |
| 08:15 | 0 | 0 | 0 | 0 | 0 | 43 | 22 | 0 | 40 | 11 | 19 | 0 | 35 | 36 | 0 | 0 | 206 |
| 08:30 | 0 | 0 | 0 | 0 | 0 | 31 | 22 | 0 | 26 | 4 | 18 | 0 | 24 | 45 | 0 | 0 | 170 |
| 08:45 | 0 | 0 | 0 | 0 | 0 | 46 | 17 | 0 | 38 | 2 | 14 | 0 | 38 | 53 | 0 | 1 | 209 |
| Total | 0 | 0 | 0 | 0 | 0 | 184 | 88 | 0 | 153 | 20 | 72 | 0 | 128 | 181 | 0 | 1 | 827 |
| *** BREAK *** | | | | | | | | | | | | | | | | | |
| 11:00 | 0 | 0 | 0 | 0 | 0 | 22 | 31 | 0 | 9 | 2 | 13 | 0 | 39 | 72 | 0 | 0 | 188 |
| 11:15 | 0 | 0 | 0 | 0 | 0 | 26 | 36 | 0 | 10 | 2 | 28 | 0 | 53 | 88 | 0 | 0 | 243 |
| 11:30 | 0 | 0 | 0 | 0 | 0 | 54 | 31 | 1 | 8 | 5 | 16 | 0 | 59 | 97 | 0 | 0 | 271 |
| 11:45 | 0 | 0 | 0 | 0 | 0 | 56 | 31 | 1 | 12 | 2 | 21 | 0 | 54 | 95 | 0 | 0 | 272 |
| Total | 0 | 0 | 0 | 0 | 0 | 158 | 129 | 2 | 39 | 11 | 78 | 0 | 205 | 352 | 0 | 0 | 974 |
| 12:00 | 0 | 0 | 0 | 0 | 0 | 57 | 36 | 0 | 19 | 3 | 25 | 0 | 56 | 103 | 0 | 0 | 299 |
| 12:15 | 0 | 0 | 0 | 0 | 0 | 54 | 26 | 0 | 15 | 1 | 26 | 0 | 43 | 87 | 0 | 0 | 252 |
| 12:30 | 0 | 0 | 0 | 0 | 0 | 63 | 36 | 0 | 11 | 3 | 12 | 0 | 56 | 84 | 0 | 0 | 265 |
| 12:45 | 0 | 0 | 0 | 0 | 0 | 57 | 33 | 0 | 18 | 4 | 16 | 0 | 49 | 83 | 0 | 0 | 260 |
| Total | 0 | 0 | 0 | 0 | 0 | 231 | 131 | 0 | 63 | 11 | 79 | 0 | 204 | 357 | 0 | 0 | 1076 |
| *** BREAK *** | | | | | | | | | | | | | | | | | |
| 15:00 | 0 | 0 | 0 | 0 | 0 | 37 | 32 | 1 | 8 | 1 | 17 | 0 | 72 | 68 | 0 | 0 | 236 |
| 15:15 | 0 | 0 | 0 | 0 | 0 | 56 | 50 | 0 | 19 | 1 | 16 | 0 | 62 | 60 | 0 | 0 | 264 |
| 15:30 | 0 | 0 | 0 | 0 | 0 | 46 | 33 | 0 | 7 | 3 | 14 | 0 | 104 | 78 | 0 | 1 | 286 |
| 15:45 | 0 | 0 | 0 | 0 | 0 | 43 | 39 | 0 | 11 | 3 | 16 | 0 | 60 | 93 | 0 | 0 | 265 |
| Total | 0 | 0 | 0 | 0 | 0 | 182 | 154 | 1 | 45 | 8 | 63 | 0 | 298 | 299 | 0 | 1 | 1051 |
| 16:00 | 0 | 0 | 0 | 0 | 0 | 60 | 33 | 0 | 8 | 0 | 12 | 0 | 107 | 77 | 0 | 0 | 297 |
| 16:15 | 0 | 0 | 0 | 0 | 0 | 67 | 33 | 0 | 10 | 3 | 14 | 1 | 71 | 73 | 0 | 1 | 273 |
| 16:30 | 0 | 0 | 0 | 0 | 0 | 53 | 37 | 0 | 8 | 0 | 14 | 0 | 122 | 79 | 0 | 0 | 313 |
| 16:45 | 0 | 0 | 0 | 0 | 0 | 51 | 43 | 0 | 14 | 1 | 18 | 0 | 93 | 90 | 0 | 0 | 310 |
| Total | 0 | 0 | 0 | 0 | 0 | 231 | 146 | 0 | 40 | 4 | 58 | 1 | 393 | 319 | 0 | 1 | 1193 |
| 17:00 | 0 | 0 | 0 | 0 | 0 | 81 | 43 | 0 | 12 | 1 | 11 | 0 | 119 | 103 | 0 | 0 | 370 |
| 17:15 | 0 | 0 | 0 | 0 | 0 | 46 | 34 | 0 | 13 | 1 | 15 | 0 | 104 | 67 | 0 | 0 | 280 |
| 17:30 | 0 | 0 | 0 | 0 | 0 | 58 | 25 | 0 | 10 | 0 | 13 | 0 | 88 | 85 | 0 | 0 | 279 |
| 17:45 | 0 | 0 | 0 | 0 | 0 | 51 | 25 | 0 | 14 | 0 | 17 | 0 | 62 | 57 | 0 | 0 | 226 |
| Total | 0 | 0 | 0 | 0 | 0 | 236 | 127 | 0 | 49 | 2 | 56 | 0 | 373 | 312 | 0 | 0 | 1155 |



MINNESOTA DEPT OF TRANSPORTATION

TRAFFIC DATA COLLECTION - METRO

I-35W at W 94th Street, east ramps

Ref.Pt.: 006.738

JAMAR # 631 BR/RE

TURN MOVEMENT COUNT

File Name : I-35W at W 94th St east ramps 2012

Site Code : 00000000

Start Date : 1/19/2012

Page No : 2

Groups Printed- Cars & Trucks

| | ramp to I-35W NB / frontage rd Southbound | | | | W 94th Street Westbound | | | | ramp from I-35W northbound Northbound | | | | W 94th Street Eastbound | | | | Int. Total |
|-------------|-------------------------------------------------|------|-------|------|----------------------------|------|-------|------|---------------------------------------------|------|-------|------|----------------------------|------|-------|------|------------|
| | Left | Thru | Right | Peds | Left | Thru | Right | Peds | Left | Thru | Right | Peds | Left | Thru | Right | Peds | |
| Grand Total | 0 | 0 | 0 | 0 | 0 | 1477 | 928 | 3 | 660 | 82 | 578 | 1 | 1857 | 2161 | 0 | 3 | 7750 |
| Apprch % | 0 | 0 | 0 | 0 | 0 | 61.3 | 38.5 | 0.1 | 50 | 6.2 | 43.8 | 0.1 | 46.2 | 53.7 | 0 | 0.1 | |
| Total % | 0 | 0 | 0 | 0 | 0 | 19.1 | 12 | 0 | 8.5 | 1.1 | 7.5 | 0 | 24 | 27.9 | 0 | 0 | |



MINNESOTA DEPT OF TRANSPORTATION

TRAFFIC DATA COLLECTION - METRO

I-35W at W 94th Street, east ramps

Ref.Pt.: 006.738

JAMAR # 631 BR/RE

TURN MOVEMENT COUNT

File Name : I-35W at W 94th St east ramps 2012

Site Code : 00000000

Start Date : 1/19/2012

Page No : 3

| Start Time | ramp to I-35W NB / frontage rd Southbound | | | | | W 94th Street Westbound | | | | | ramp from I-35W northbound Northbound | | | | | W 94th Street Eastbound | | | | | Int. Total |
|------------------------------------------------------|-------------------------------------------|------|-------|------|------------|-------------------------|------|-------|------|------------|---------------------------------------|------|-------|------|------------|-------------------------|------|-------|------|------------|------------|
| | Left | Thru | Right | Peds | App. Total | Left | Thru | Right | Peds | App. Total | Left | Thru | Right | Peds | App. Total | Left | Thru | Right | Peds | App. Total | |
| Peak Hour Analysis From 06:00 to 08:45 - Peak 1 of 1 | | | | | | | | | | | | | | | | | | | | | |
| Peak Hour for Entire Intersection Begins at 07:15 | | | | | | | | | | | | | | | | | | | | | |
| 07:15 | 0 | 0 | 0 | 0 | 0 | 0 | 38 | 27 | 0 | 65 | 31 | 3 | 15 | 0 | 49 | 51 | 46 | 0 | 0 | 97 | 211 |
| 07:30 | 0 | 0 | 0 | 0 | 0 | 0 | 51 | 21 | 0 | 72 | 40 | 3 | 14 | 0 | 57 | 36 | 59 | 0 | 0 | 95 | 224 |
| 07:45 | 0 | 0 | 0 | 0 | 0 | 0 | 56 | 17 | 0 | 73 | 45 | 8 | 32 | 0 | 85 | 31 | 73 | 0 | 0 | 104 | 262 |
| 08:00 | 0 | 0 | 0 | 0 | 0 | 0 | 64 | 27 | 0 | 91 | 49 | 3 | 21 | 0 | 73 | 31 | 47 | 0 | 0 | 78 | 242 |
| Total Volume | 0 | 0 | 0 | 0 | 0 | 0 | 209 | 92 | 0 | 301 | 165 | 17 | 82 | 0 | 264 | 149 | 225 | 0 | 0 | 374 | 939 |
| % App. Total | 0 | 0 | 0 | 0 | 0 | 0 | 69.4 | 30.6 | 0 | | 62.5 | 6.4 | 31.1 | 0 | | 39.8 | 60.2 | 0 | 0 | | |
| PHF | .000 | .000 | .000 | .000 | .000 | .000 | .816 | .852 | .000 | .827 | .842 | .531 | .641 | .000 | .776 | .730 | .771 | .000 | .000 | .899 | .896 |

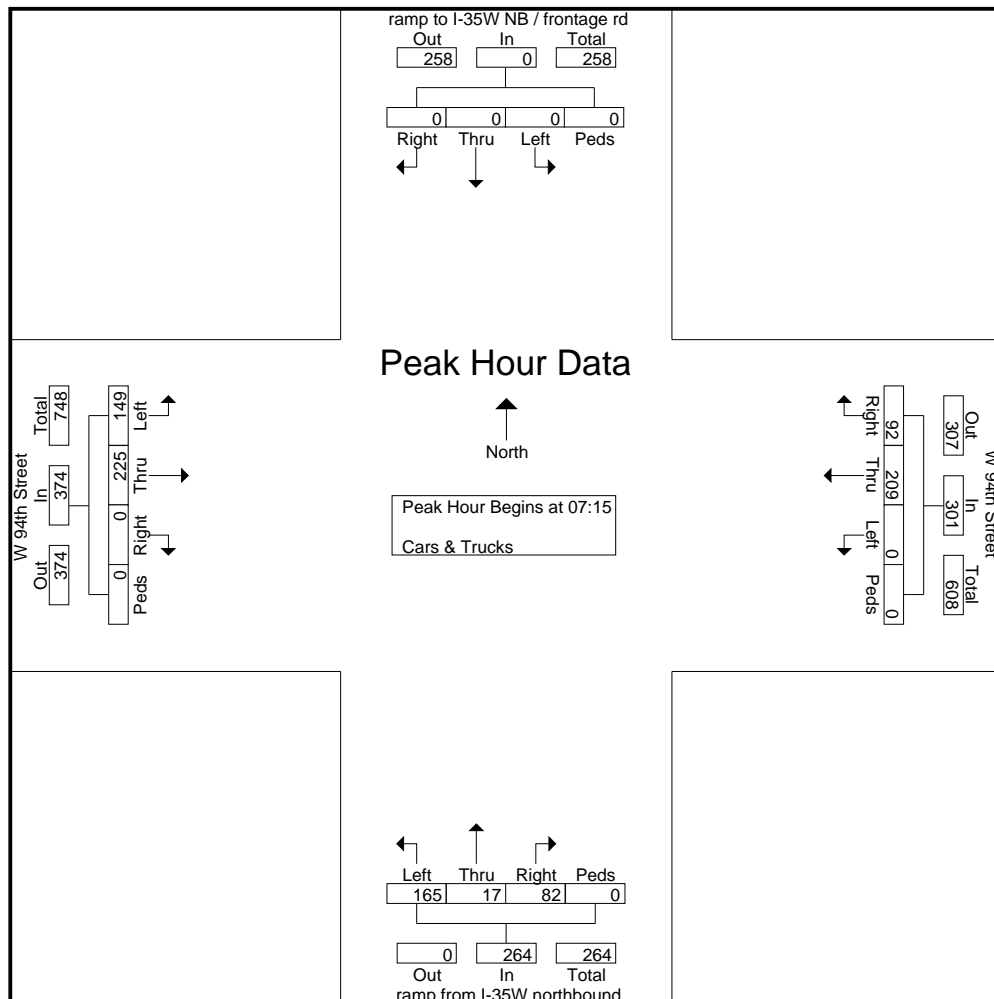



MINNESOTA DEPT OF TRANSPORTATION

TRAFFIC DATA COLLECTION - METRO

I-35W at W 94th Street, east ramps
 Ref.Pt.: 006.738
 JAMAR # 631 BR/RE
 TURN MOVEMENT COUNT

File Name : I-35W at W 94th St east ramps 2012
 Site Code : 00000000
 Start Date : 1/19/2012
 Page No : 4

| Start Time | ramp to I-35W NB / frontage rd Southbound | | | | | W 94th Street Westbound | | | | | ramp from I-35W northbound Northbound | | | | | W 94th Street Eastbound | | | | | Int. Total |
|------------------------------------------------------|-------------------------------------------|------|-------|------|------------|-------------------------|------|-------|------|------------|---------------------------------------|------|-------|------|------------|-------------------------|------|-------|------|------------|------------|
| | Left | Thru | Right | Peds | App. Total | Left | Thru | Right | Peds | App. Total | Left | Thru | Right | Peds | App. Total | Left | Thru | Right | Peds | App. Total | |
| Peak Hour Analysis From 15:00 to 17:45 - Peak 1 of 1 | | | | | | | | | | | | | | | | | | | | | |
| Peak Hour for Entire Intersection Begins at 16:30 | | | | | | | | | | | | | | | | | | | | | |
| 16:30 | 0 | 0 | 0 | 0 | 0 | 0 | 53 | 37 | 0 | 90 | 8 | 0 | 14 | 0 | 22 | 122 | 79 | 0 | 0 | 201 | 313 |
| 16:45 | 0 | 0 | 0 | 0 | 0 | 0 | 51 | 43 | 0 | 94 | 14 | 1 | 18 | 0 | 33 | 93 | 90 | 0 | 0 | 183 | 310 |
| 17:00 | 0 | 0 | 0 | 0 | 0 | 0 | 81 | 43 | 0 | 124 | 12 | 1 | 11 | 0 | 24 | 119 | 103 | 0 | 0 | 222 | 370 |
| 17:15 | 0 | 0 | 0 | 0 | 0 | 0 | 46 | 34 | 0 | 80 | 13 | 1 | 15 | 0 | 29 | 104 | 67 | 0 | 0 | 171 | 280 |
| Total Volume | 0 | 0 | 0 | 0 | 0 | 0 | 231 | 157 | 0 | 388 | 47 | 3 | 58 | 0 | 108 | 438 | 339 | 0 | 0 | 777 | 1273 |
| % App. Total | 0 | 0 | 0 | 0 | 0 | 0 | 59.5 | 40.5 | 0 | | 43.5 | 2.8 | 53.7 | 0 | | 56.4 | 43.6 | 0 | 0 | | |
| PHF | .000 | .000 | .000 | .000 | .000 | .000 | .713 | .913 | .000 | .782 | .839 | .750 | .806 | .000 | .818 | .898 | .823 | .000 | .000 | .875 | .860 |

