



MINNESOTA DEPT OF TRANSPORTATION

TRAFFIC DATA COLLECTION - METRO

I-35 AT TH-95, EAST RAMPS
 REF.PT. 054.370
 DATA COLLECTED BY TDI
 TURN MOVEMENT COUNT

File Name : I-35 AT TH-95 EAST RAMPS 2007
 Site Code : 00198753
 Start Date : 6/5/2007
 Page No : 1

Groups Printed- Unshifted

Start Time	RAMP TO I-35 NB Southbound				MN-95 Westbound				RAMP FROM I-35 NB Northbound				MN-95 Eastbound				Int. Total
	Left	Thru	Right	Peds	Left	Thru	Right	Peds	Left	Thru	Right	Peds	Left	Thru	Right	Peds	
06:00	0	0	0	0	0	127	12	0	8	0	10	0	7	53	0	0	217
06:15	0	0	0	0	0	127	9	0	14	0	21	1	11	73	0	0	256
06:30	0	0	0	0	0	138	15	0	19	0	23	0	10	75	0	0	280
06:45	0	0	0	0	0	139	19	0	12	0	20	0	10	96	0	0	296
Total	0	0	0	0	0	531	55	0	53	0	74	1	38	297	0	0	1049
07:00	0	0	0	0	0	146	18	0	21	0	25	2	7	93	0	0	312
07:15	0	0	0	0	0	126	15	0	36	0	21	1	5	139	0	0	343
07:30	0	0	0	0	0	129	20	0	30	0	39	7	11	158	0	0	394
07:45	0	0	0	0	0	154	21	0	31	0	30	5	9	185	0	0	435
Total	0	0	0	0	0	555	74	0	118	0	115	15	32	575	0	0	1484
08:00	0	0	0	0	0	177	17	0	24	0	32	0	9	125	0	0	384
08:15	0	0	0	0	0	136	22	0	36	0	34	1	4	92	0	0	325
08:30	0	0	0	0	0	124	25	0	26	0	36	0	9	87	0	0	307
08:45	0	0	0	2	0	115	22	0	25	0	35	0	14	105	0	0	318
Total	0	0	0	2	0	552	86	0	111	0	137	1	36	409	0	0	1334
*** BREAK ***																	
11:00	0	0	0	0	0	93	22	0	17	1	34	0	12	121	0	0	300
11:15	0	0	0	0	0	123	18	0	36	0	37	0	12	95	0	0	321
11:30	0	0	0	0	0	117	19	0	38	2	37	1	14	130	0	0	358
11:45	0	0	0	0	0	163	22	0	26	0	32	0	17	141	0	0	401
Total	0	0	0	0	0	496	81	0	117	3	140	1	55	487	0	0	1380
12:00	0	0	0	0	0	160	27	0	32	0	37	0	16	103	0	0	375
12:15	0	0	0	0	0	147	21	0	20	0	33	0	12	122	0	0	355
12:30	0	0	0	0	0	149	13	0	27	0	32	0	14	112	0	0	347
12:45	0	0	0	0	0	137	24	0	24	0	36	0	18	114	0	0	353
Total	0	0	0	0	0	593	85	0	103	0	138	0	60	451	0	0	1430
*** BREAK ***																	
15:00	0	0	0	0	0	176	30	0	48	0	65	1	11	113	0	0	444
15:15	0	0	0	0	0	197	29	0	44	0	53	0	14	96	0	0	433
15:30	0	0	0	5	0	165	25	0	50	0	64	1	15	137	0	0	462
15:45	0	0	0	0	0	177	28	0	78	0	68	4	16	147	0	0	518
Total	0	0	0	5	0	715	112	0	220	0	250	6	56	493	0	0	1857
16:00	0	0	0	0	0	185	31	0	83	0	91	2	18	143	0	0	553
16:15	0	0	0	0	0	175	43	0	84	0	93	1	15	140	0	0	551
16:30	0	0	0	0	0	184	39	0	65	0	97	0	18	140	0	0	543
16:45	0	0	0	0	0	177	30	0	86	0	105	1	16	160	0	0	575
Total	0	0	0	0	0	721	143	0	318	0	386	4	67	583	0	0	2222
17:00	0	0	0	0	0	192	29	0	67	0	84	1	22	143	0	0	538
17:15	0	0	0	0	0	151	36	0	85	0	104	0	17	162	0	0	555
17:30	0	0	0	0	0	128	24	0	99	0	100	0	17	173	0	0	541
17:45	0	0	0	0	0	156	30	0	73	0	102	0	16	194	0	0	571
Total	0	0	0	0	0	627	119	0	324	0	390	1	72	672	0	0	2205



MINNESOTA DEPT OF TRANSPORTATION
 TRAFFIC DATA COLLECTION - METRO

I-35 AT TH-95, EAST RAMPS
 REF.PT. 054.370
 DATA COLLECTED BY TDI
 TURN MOVEMENT COUNT

File Name : I-35 AT TH-95 EAST RAMPS 2007
 Site Code : 00198753
 Start Date : 6/5/2007
 Page No : 2

Groups Printed- Unshifted

	RAMP TO I-35 NB Southbound				MN-95 Westbound				RAMP FROM I-35 NB Northbound				MN-95 Eastbound				Int. Total
	Left	Thru	Right	Peds	Left	Thru	Right	Peds	Left	Thru	Right	Peds	Left	Thru	Right	Peds	
Grand Total	0	0	0	7	0	4790	755	0	1364	3	1630	29	416	3967	0	0	12961
Apprch %	0	0	0	100	0	86.4	13.6	0	45.1	0.1	53.9	1	9.5	90.5	0	0	
Total %	0	0	0	0.1	0	37	5.8	0	10.5	0	12.6	0.2	3.2	30.6	0	0	



MINNESOTA DEPT OF TRANSPORTATION

TRAFFIC DATA COLLECTION - METRO

I-35 AT TH-95, EAST RAMPS
 REF.PT. 054.370
 DATA COLLECTED BY TDI
 TURN MOVEMENT COUNT

File Name : I-35 AT TH-95 EAST RAMPS 2007
 Site Code : 00198753
 Start Date : 6/5/2007
 Page No : 3

Start Time	RAMP TO I-35 NB Southbound					MN-95 Westbound					RAMP FROM I-35 NB Northbound					MN-95 Eastbound					Int. Total
	Left	Thru	Right	Peds	App. Total	Left	Thru	Right	Peds	App. Total	Left	Thru	Right	Peds	App. Total	Left	Thru	Right	Peds	App. Total	
Peak Hour Analysis From 06:00 to 08:45 - Peak 1 of 1																					
Peak Hour for Entire Intersection Begins at 07:15																					
07:15	0	0	0	0	0	0	126	15	0	141	36	0	21	1	58	5	139	0	0	144	343
07:30	0	0	0	0	0	0	129	20	0	149	30	0	39	7	76	11	158	0	0	169	394
07:45	0	0	0	0	0	0	154	21	0	175	31	0	30	5	66	9	185	0	0	194	435
08:00	0	0	0	0	0	0	177	17	0	194	24	0	32	0	56	9	125	0	0	134	384
Total Volume	0	0	0	0	0	0	586	73	0	659	121	0	122	13	256	34	607	0	0	641	1556
% App. Total	0	0	0	0	0	0	88.9	11.1	0		47.3	0	47.7	5.1		5.3	94.7	0	0		
PHF	.000	.000	.000	.000	.000	.000	.828	.869	.000	.849	.840	.000	.782	.464	.842	.773	.820	.000	.000	.826	.894

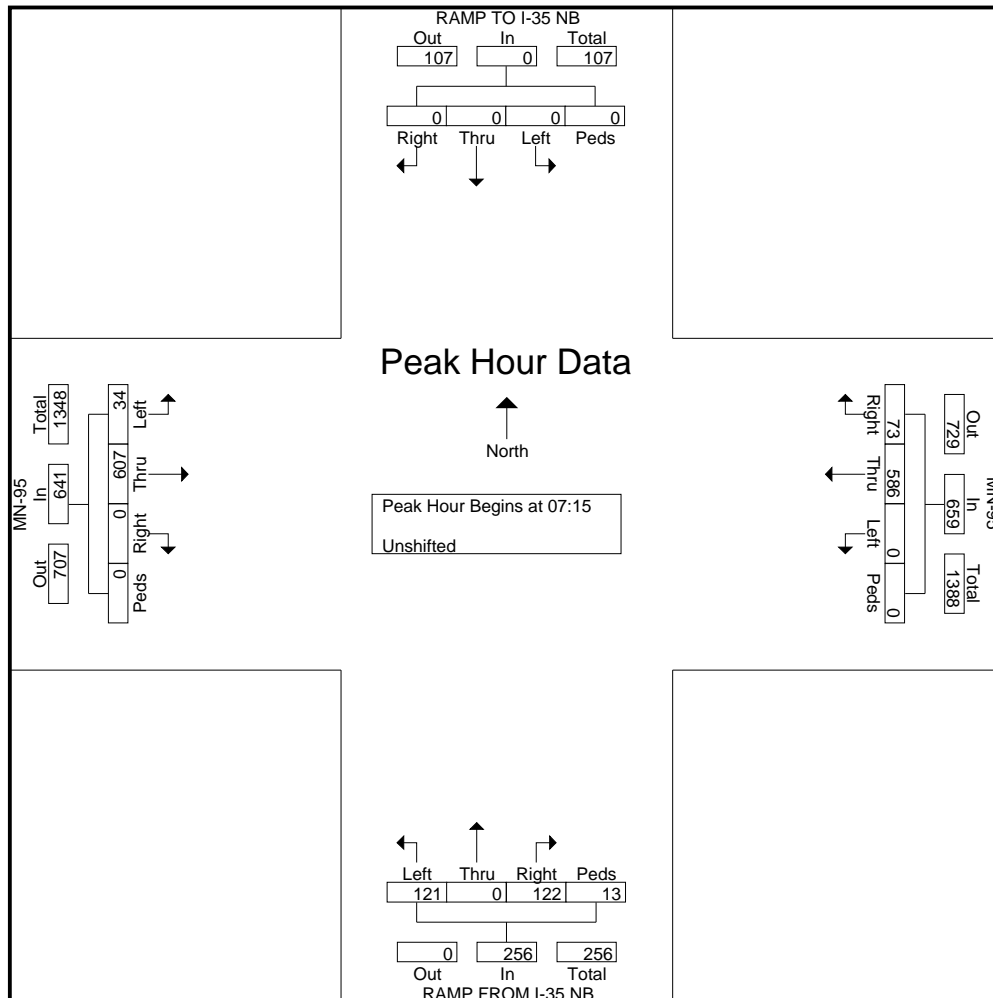



MINNESOTA DEPT OF TRANSPORTATION

TRAFFIC DATA COLLECTION - METRO

I-35 AT TH-95, EAST RAMPS
 REF.PT. 054.370
 DATA COLLECTED BY TDI
 TURN MOVEMENT COUNT

File Name : I-35 AT TH-95 EAST RAMPS 2007
 Site Code : 00198753
 Start Date : 6/5/2007
 Page No : 4

Start Time	RAMP TO I-35 NB Southbound					MN-95 Westbound					RAMP FROM I-35 NB Northbound					MN-95 Eastbound					Int. Total
	Left	Thru	Right	Peds	App. Total	Left	Thru	Right	Peds	App. Total	Left	Thru	Right	Peds	App. Total	Left	Thru	Right	Peds	App. Total	
Peak Hour Analysis From 15:00 to 17:45 - Peak 1 of 1																					
Peak Hour for Entire Intersection Begins at 16:00																					
16:00	0	0	0	0	0	0	185	31	0	216	83	0	91	2	176	18	143	0	0	161	553
16:15	0	0	0	0	0	0	175	43	0	218	84	0	93	1	178	15	140	0	0	155	551
16:30	0	0	0	0	0	0	184	39	0	223	65	0	97	0	162	18	140	0	0	158	543
16:45	0	0	0	0	0	0	177	30	0	207	86	0	105	1	192	16	160	0	0	176	575
Total Volume	0	0	0	0	0	0	721	143	0	864	318	0	386	4	708	67	583	0	0	650	2222
% App. Total	0	0	0	0	0	0	83.4	16.6	0		44.9	0	54.5	0.6		10.3	89.7	0	0		
PHF	.000	.000	.000	.000	.000	.000	.974	.831	.000	.969	.924	.000	.919	.500	.922	.931	.911	.000	.000	.923	.966

