

# MN Dept of Transportation

TRAFFIC DATA COLLECTION - Metro

I-35 at TH-97, east ramps  
 Ref.Pt.: 129.388  
 Video  
 TURN MOVEMENT COUNT

File Name : i-35 at th-97 e ramp 2014  
 Site Code :  
 Start Date : 6/10/2014  
 Page No : 1

Groups Printed- Cars +

Start Time	ramp to I-35 NB Southbound				TH-97 Westbound				ramp from I-35 NB Northbound				TH-97 Eastbound				Int. Total
	Left	Thru	Right	Peds	Left	Thru	Right	Peds	Left	Thru	Right	Peds	Left	Thru	Right	Peds	
06:00	0	0	0	0	0	253	4	0	10	0	33	0	12	27	0	0	339
06:15	0	0	0	0	0	283	5	0	15	0	40	0	17	32	0	0	392
06:30	0	0	0	0	0	253	5	0	14	0	65	0	14	34	0	0	385
06:45	0	0	0	0	0	232	19	0	8	0	50	0	18	34	0	0	361
Total	0	0	0	0	0	1021	33	0	47	0	188	0	61	127	0	0	1477
07:00	0	0	0	0	0	262	15	0	11	0	39	0	22	35	0	0	384
07:15	0	0	0	0	0	211	15	0	18	2	58	0	6	42	0	0	352
07:30	0	0	0	0	0	200	18	0	16	0	63	0	18	46	0	0	361
07:45	0	0	0	0	0	199	15	0	24	0	74	0	23	59	0	0	394
Total	0	0	0	0	0	872	63	0	69	2	234	0	69	182	0	0	1491
08:00	0	0	0	0	0	176	22	0	16	0	60	0	26	50	0	0	350
08:15	0	0	0	0	0	183	15	0	10	0	70	0	20	40	0	0	338
08:30	0	0	0	0	0	184	21	0	12	0	51	0	18	41	0	0	327
08:45	0	0	0	0	0	149	21	0	11	0	72	0	23	38	0	0	314
Total	0	0	0	0	0	692	79	0	49	0	253	0	87	169	0	0	1329
09:00	0	0	0	0	0	139	19	0	22	0	59	0	21	30	0	0	290
09:15	0	0	0	0	0	159	19	0	26	0	60	0	29	46	0	0	339
**** BREAK ****																	
Total	0	0	0	0	0	298	38	0	48	0	119	0	50	76	0	0	629
**** BREAK ****																	
11:00	0	0	0	0	0	117	15	0	30	1	67	0	24	39	0	0	293
11:15	0	0	0	0	0	116	22	0	20	0	86	0	22	37	0	0	303
11:30	0	0	0	0	0	131	11	0	28	0	65	0	31	46	0	0	312
11:45	0	0	0	0	0	95	15	0	19	0	67	0	22	52	0	0	270
Total	0	0	0	0	0	459	63	0	97	1	285	0	99	174	0	0	1178
12:00	0	0	0	0	0	91	16	0	26	0	74	0	42	54	0	0	303
12:15	0	0	0	0	0	122	25	0	25	0	65	0	24	47	0	0	308
12:30	0	0	0	0	0	105	15	0	35	0	74	0	34	35	0	0	298
12:45	0	0	0	0	0	106	12	0	26	0	72	0	24	67	0	0	307
Total	0	0	0	0	0	424	68	0	112	0	285	0	124	203	0	0	1216
**** BREAK ****																	
15:00	0	0	0	0	0	116	24	0	34	0	142	0	44	62	0	0	422
15:15	0	0	0	0	0	111	16	0	33	0	184	0	57	86	0	0	487
15:30	0	0	0	0	0	115	27	0	44	0	178	0	42	73	0	0	479
15:45	0	0	0	0	0	93	45	0	30	0	203	0	71	72	0	0	514
Total	0	0	0	0	0	435	112	0	141	0	707	0	214	293	0	0	1902
16:00	0	0	0	0	0	128	36	0	36	0	184	0	34	67	0	0	485
16:15	0	0	0	0	0	120	39	0	40	2	241	0	76	85	0	0	603
16:30	0	0	0	0	0	137	30	0	34	0	251	0	70	84	0	0	606
16:45	0	0	0	0	0	121	38	0	46	0	265	0	54	94	0	0	618
Total	0	0	0	0	0	506	143	0	156	2	941	0	234	330	0	0	2312
17:00	0	0	0	0	0	135	44	0	52	1	260	0	106	82	0	0	680
17:15	0	0	0	0	0	146	24	0	55	0	259	0	65	112	0	0	661
17:30	0	0	0	0	0	140	33	0	34	0	222	0	90	105	0	0	624
17:45	0	0	0	0	0	139	29	0	51	0	205	0	56	82	0	0	562
Total	0	0	0	0	0	560	130	0	192	1	946	0	317	381	0	0	2527
Grand Total	0	0	0	0	0	5267	729	0	911	6	3958	0	1255	1935	0	0	14061
Apprch %	0	0	0	0	0	87.8	12.2	0	18.7	0.1	81.2	0	39.3	60.7	0	0	
Total %	0	0	0	0	0	37.5	5.2	0	6.5	0	28.1	0	8.9	13.8	0	0	

# MN Dept of Transportation

TRAFFIC DATA COLLECTION - Metro

I-35 at TH-97, east ramps

Ref.Pt.: 129.388

Video

TURN MOVEMENT COUNT

File Name : i-35 at th-97 e ramp 2014

Site Code :

Start Date : 6/10/2014

Page No : 2

Start Time	ramp to I-35 NB Southbound					TH-97 Westbound					ramp from I-35 NB Northbound					TH-97 Eastbound					Int. Total
	Left	Thru	Right	Peds	App. Total	Left	Thru	Right	Peds	App. Total	Left	Thru	Right	Peds	App. Total	Left	Thru	Right	Peds	App. Total	
Peak Hour Analysis From 06:00 to 09:30 - Peak 1 of 1																					
Peak Hour for Entire Intersection Begins at 06:15																					
06:15	0	0	0	0	0	0	283	5	0	288	15	0	40	0	55	17	32	0	0	49	392
06:30	0	0	0	0	0	0	253	5	0	258	14	0	65	0	79	14	34	0	0	48	385
06:45	0	0	0	0	0	0	232	19	0	251	8	0	50	0	58	18	34	0	0	52	361
07:00	0	0	0	0	0	0	262	15	0	277	11	0	39	0	50	22	35	0	0	57	384
Total Volume	0	0	0	0	0	0	1030	44	0	1074	48	0	194	0	242	71	135	0	0	206	1522
% App. Total	0	0	0	0	0	0	95.9	4.1	0		19.8	0	80.2	0		34.5	65.5	0	0		
PHF	.000	.000	.000	.000	.000	.000	.910	.579	.000	.932	.800	.000	.746	.000	.766	.807	.964	.000	.000	.904	.971

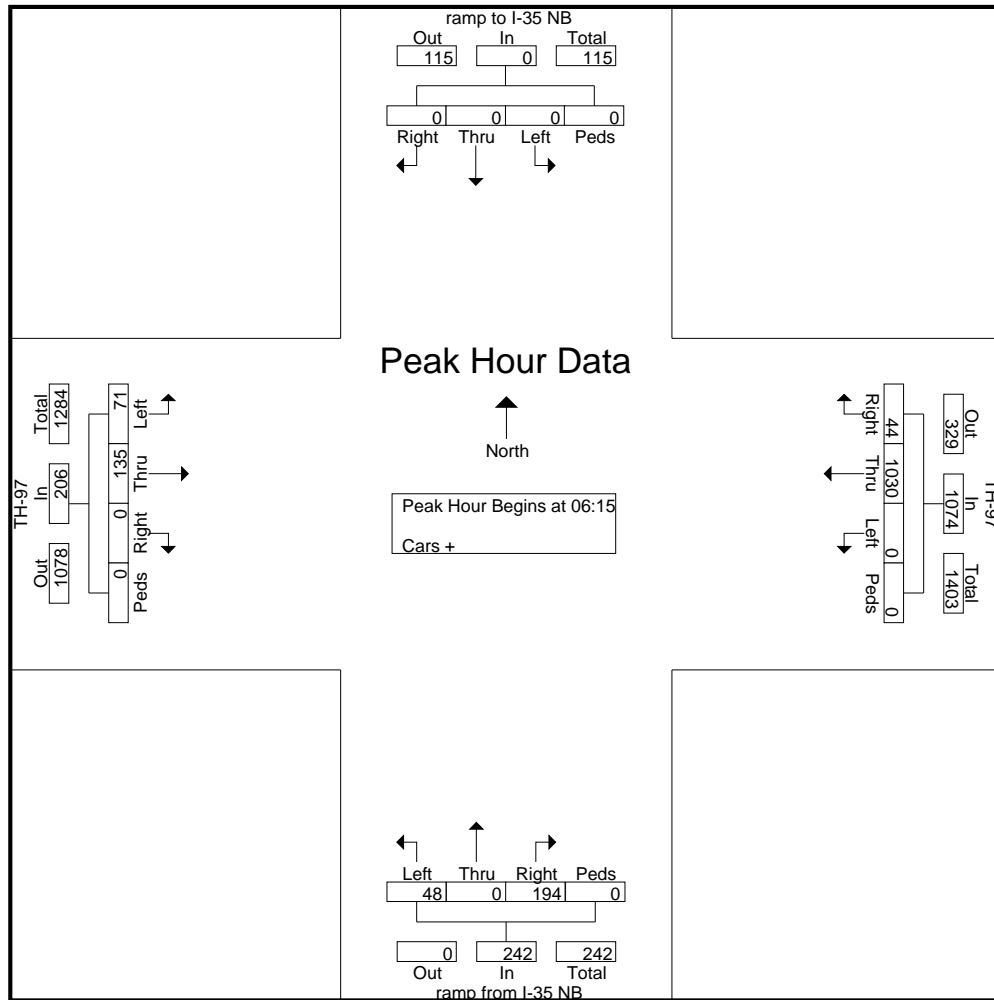

# MN Dept of Transportation

TRAFFIC DATA COLLECTION - Metro

I-35 at TH-97, east ramps  
 Ref.Pt.: 129.388  
 Video  
 TURN MOVEMENT COUNT

File Name : i-35 at th-97 e ramp 2014  
 Site Code :  
 Start Date : 6/10/2014  
 Page No : 3

Start Time	ramp to I-35 NB Southbound					TH-97 Westbound					ramp from I-35 NB Northbound					TH-97 Eastbound					Int. Total
	Left	Thru	Right	Peds	App. Total	Left	Thru	Right	Peds	App. Total	Left	Thru	Right	Peds	App. Total	Left	Thru	Right	Peds	App. Total	
Peak Hour Analysis From 15:00 to 17:45 - Peak 1 of 1																					
Peak Hour for Entire Intersection Begins at 16:45																					
16:45	0	0	0	0	0	0	121	38	0	159	46	0	265	0	311	54	94	0	0	148	618
17:00	0	0	0	0	0	0	135	44	0	179	52	1	260	0	313	106	82	0	0	188	680
17:15	0	0	0	0	0	0	146	24	0	170	55	0	259	0	314	65	112	0	0	177	661
17:30	0	0	0	0	0	0	140	33	0	173	34	0	222	0	256	90	105	0	0	195	624
Total Volume	0	0	0	0	0	0	542	139	0	681	187	1	1006	0	1194	315	393	0	0	708	2583
% App. Total	0	0	0	0	0	0	79.6	20.4	0		15.7	0.1	84.3	0		44.5	55.5	0	0		
PHF	.000	.000	.000	.000	.000	.000	.928	.790	.000	.951	.850	.250	.949	.000	.951	.743	.877	.000	.000	.908	.950

