

Associated Consulting Services (ACS)  
 Roseville, MN 55113  
 -- TRAFFIC DATA --

US-8 at US-61 North Ramp\_2022  
 City: Forest Lake  
 Data Prepared By: ACS  
 TURNING MOVEMENT COUNT

File Name : US-8 at US-61 North Ramp\_2022  
 Site Code :  
 Start Date : 5/3/2022  
 Page No : 1

Groups Printed- Cars - Trucks

Start Time	US-61 Southbound				Ramp from WB US-8 Westbound				US-61 Northbound				Ramp to WB US-8 Eastbound				Int. Total
	Left	Thru	Right	Peds	Left	Thru	Right	Peds	Left	Thru	Right	Peds	Left	Thru	Right	Peds	
06:00	0	34	39	0	15	1	2	0	1	25	0	0	11	0	2	0	130
06:15	0	31	42	0	16	1	1	0	1	14	0	0	9	0	1	0	116
06:30	0	54	43	0	28	1	5	0	4	29	0	0	13	0	0	0	177
06:45	0	75	41	0	34	0	3	0	1	34	0	0	15	0	3	0	206
Total	0	194	165	0	93	3	11	0	7	102	0	0	48	0	6	0	629
07:00	0	90	39	0	42	2	5	0	1	23	0	0	11	0	1	0	214
07:15	0	109	57	0	54	2	7	0	6	45	0	0	15	0	0	0	295
07:30	0	129	40	0	57	1	8	0	8	62	0	0	22	0	1	0	328
07:45	0	93	33	0	55	0	3	0	12	61	0	0	30	0	2	0	289
Total	0	421	169	0	208	5	23	0	27	191	0	0	78	0	4	0	1126
08:00	0	59	23	0	40	0	8	0	7	49	0	0	22	0	2	0	210
08:15	0	42	24	0	30	2	7	0	4	40	0	0	25	0	1	0	175
08:30	0	70	30	0	48	1	2	0	2	34	0	0	13	0	0	0	200
08:45	0	72	23	0	46	1	10	0	3	49	0	0	22	0	4	0	230
Total	0	243	100	0	164	4	27	0	16	172	0	0	82	0	7	0	815
09:00	0	83	27	0	32	2	1	0	5	48	0	0	18	0	1	0	217
09:15	0	73	30	0	34	0	3	0	6	30	0	0	21	0	1	0	198
09:30	0	59	20	0	42	0	9	0	4	43	0	0	18	0	1	0	196
09:45	0	66	17	0	31	0	6	0	1	44	0	0	13	0	1	0	179
Total	0	281	94	0	139	2	19	0	16	165	0	0	70	0	4	0	790
10:00	0	52	23	0	33	1	4	0	2	34	0	0	17	0	1	0	167
10:15	0	59	23	0	30	3	3	0	3	36	0	0	14	0	0	0	171
10:30	0	64	20	0	39	3	5	0	3	41	0	0	17	0	1	0	193
10:45	0	70	16	0	34	0	6	0	3	49	0	0	8	0	1	0	187
Total	0	245	82	0	136	7	18	0	11	160	0	0	56	0	3	0	718
11:00	0	61	14	0	33	0	7	0	1	37	0	0	14	0	1	0	168
11:15	0	76	14	0	41	0	6	0	2	54	0	0	21	0	1	0	215
11:30	0	77	22	0	37	0	13	0	4	57	0	0	21	0	0	0	231
11:45	0	66	19	0	37	0	8	0	1	61	0	0	14	0	0	0	206
Total	0	280	69	0	148	0	34	0	8	209	0	0	70	0	2	0	820
12:00	0	72	24	0	32	0	6	0	1	50	0	0	3	0	1	0	189
12:15	0	75	16	0	36	2	3	0	4	69	0	0	17	0	0	0	222
12:30	0	65	17	0	41	2	4	0	1	72	0	0	13	0	2	0	217
12:45	0	70	14	0	52	1	7	0	1	54	0	0	18	0	0	0	217
Total	0	282	71	0	161	5	20	0	7	245	0	0	51	0	3	0	845
13:00	0	70	21	0	31	1	5	0	0	63	0	0	13	0	3	0	207
13:15	0	67	19	0	35	3	7	0	2	65	0	0	18	0	2	0	218
13:30	0	81	13	0	43	1	4	0	8	60	0	0	20	0	5	0	235
13:45	0	89	17	0	42	1	5	0	2	59	0	0	16	0	2	0	233
Total	0	307	70	0	151	6	21	0	12	247	0	0	67	0	12	0	893
14:00	0	79	16	0	47	2	8	0	4	64	0	0	19	0	2	0	241
14:15	0	49	21	0	39	0	4	0	3	79	0	0	20	0	0	0	215
14:30	0	63	20	0	34	0	9	0	5	119	0	0	29	0	3	0	282
14:45	0	73	13	0	43	1	9	0	8	117	0	0	35	0	0	0	299
Total	0	264	70	0	163	3	30	0	20	379	0	0	103	0	5	0	1037

Associated Consulting Services (ACS)  
 Roseville, MN 55113  
 -- TRAFFIC DATA --

US-8 at US-61 North Ramp\_2022  
 City: Forest Lake  
 Data Prepared By: ACS  
 TURNING MOVEMENT COUNT

File Name : US-8 at US-61 North Ramp\_2022  
 Site Code :  
 Start Date : 5/3/2022  
 Page No : 2

Groups Printed- Cars - Trucks

Start Time	US-61 Southbound				Ramp from WB US-8 Westbound				US-61 Northbound				Ramp to WB US-8 Eastbound				Int. Total
	Left	Thru	Right	Peds	Left	Thru	Right	Peds	Left	Thru	Right	Peds	Left	Thru	Right	Peds	
15:00	0	79	24	0	43	1	7	0	4	102	0	0	25	0	1	0	286
15:15	0	74	27	0	45	5	7	0	4	113	0	0	41	0	1	0	317
15:30	0	88	43	0	46	3	7	0	9	102	0	0	65	0	2	0	365
15:45	0	116	38	0	40	2	6	0	3	90	0	0	48	0	1	0	344
Total	0	357	132	0	174	11	27	0	20	407	0	0	179	0	5	0	1312
16:00	0	102	37	0	51	3	12	0	1	94	0	0	54	0	2	0	356
16:15	0	111	38	0	40	3	9	0	8	114	0	0	51	0	1	0	375
16:30	0	114	55	0	60	0	9	0	9	94	0	0	44	0	3	0	388
16:45	0	101	35	0	59	1	7	0	7	89	0	0	61	0	3	0	363
Total	0	428	165	0	210	7	37	0	25	391	0	0	210	0	9	0	1482
17:00	0	97	28	0	44	1	8	0	9	108	0	0	56	0	5	0	356
17:15	0	82	29	0	64	6	8	0	3	93	0	0	46	0	1	0	332
17:30	0	50	22	0	30	1	6	0	5	98	0	0	38	0	3	0	253
17:45	0	76	20	0	45	5	10	0	4	83	0	0	42	0	1	0	286
Total	0	305	99	0	183	13	32	0	21	382	0	0	182	0	10	0	1227
Grand Total	0	3607	1286	0	1930	66	299	0	190	3050	0	0	1196	0	70	0	11694
Apprch %	0	73.7	26.3	0	84.1	2.9	13	0	5.9	94.1	0	0	94.5	0	5.5	0	
Total %	0	30.8	11	0	16.5	0.6	2.6	0	1.6	26.1	0	0	10.2	0	0.6	0	
Cars	0	3479	1233	0	1877	63	262	0	177	2975	0	0	1128	0	60	0	11254
% Cars	0	96.5	95.9	0	97.3	95.5	87.6	0	93.2	97.5	0	0	94.3	0	85.7	0	96.2
Trucks	0	128	53	0	53	3	37	0	13	75	0	0	68	0	10	0	440
% Trucks	0	3.5	4.1	0	2.7	4.5	12.4	0	6.8	2.5	0	0	5.7	0	14.3	0	3.8

Associated Consulting Services (ACS)  
 Roseville, MN 55113  
 -- TRAFFIC DATA --

US-8 at US-61 North Ramp\_2022  
 City: Forest Lake  
 Data Prepared By: ACS  
 TURNING MOVEMENT COUNT

File Name : US-8 at US-61 North Ramp\_2022  
 Site Code :  
 Start Date : 5/3/2022  
 Page No : 3

Start Time	US-61 Southbound					Ramp from WB US-8 Westbound					US-61 Northbound					Ramp to WB US-8 Eastbound					Int. Total
	Left	Thru	Right	Peds	App. Total	Left	Thru	Right	Peds	App. Total	Left	Thru	Right	Peds	App. Total	Left	Thru	Right	Peds	App. Total	
Peak Hour Analysis From 06:00 to 11:45 - Peak 1 of 1																					
Peak Hour for Entire Intersection Begins at 07:00																					
07:00	0	90	39	0	129	42	2	5	0	49	1	23	0	0	24	11	0	1	0	12	214
07:15	0	109	57	0	166	54	2	7	0	63	6	45	0	0	51	15	0	0	0	15	295
07:30	0	129	40	0	169	57	1	8	0	66	8	62	0	0	70	22	0	1	0	23	328
07:45	0	93	33	0	126	55	0	3	0	58	12	61	0	0	73	30	0	2	0	32	289
Total Volume	0	421	169	0	590	208	5	23	0	236	27	191	0	0	218	78	0	4	0	82	1126
% App. Total	0	71.4	28.6	0		88.1	2.1	9.7	0		12.4	87.6	0	0		95.1	0	4.9	0		
PHF	.000	.816	.741	.000	.873	.912	.625	.719	.000	.894	.563	.770	.000	.000	.747	.650	.000	.500	.000	.641	.858

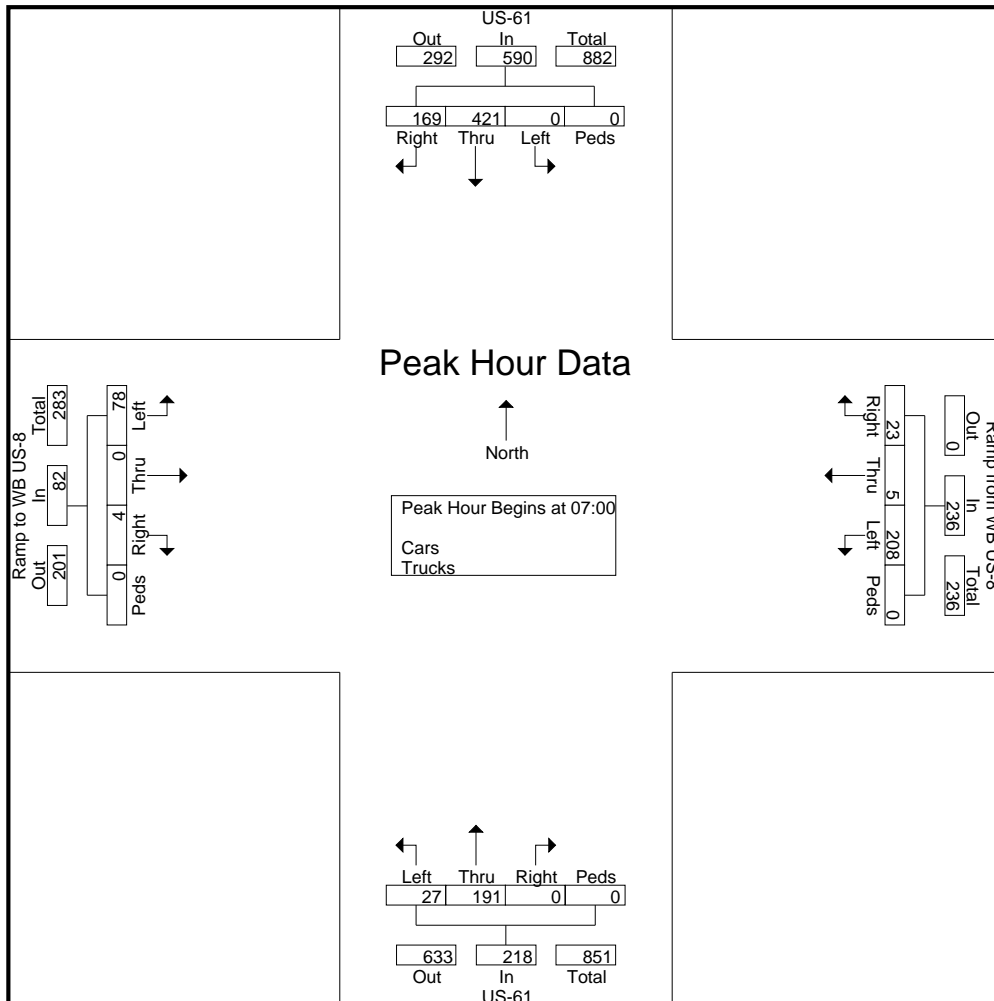

Associated Consulting Services (ACS)  
 Roseville, MN 55113  
 -- TRAFFIC DATA --

US-8 at US-61 North Ramp\_2022  
 City: Forest Lake  
 Data Prepared By: ACS  
 TURNING MOVEMENT COUNT

File Name : US-8 at US-61 North Ramp\_2022  
 Site Code :  
 Start Date : 5/3/2022  
 Page No : 4

Start Time	US-61 Southbound					Ramp from WB US-8 Westbound					US-61 Northbound					Ramp to WB US-8 Eastbound					Int. Total
	Left	Thru	Right	Peds	App. Total	Left	Thru	Right	Peds	App. Total	Left	Thru	Right	Peds	App. Total	Left	Thru	Right	Peds	App. Total	
Peak Hour Analysis From 12:00 to 17:45 - Peak 1 of 1																					
Peak Hour for Entire Intersection Begins at 16:00																					
16:00	0	102	37	0	139	51	3	12	0	66	1	94	0	0	95	54	0	2	0	56	356
16:15	0	111	38	0	149	40	3	9	0	52	8	114	0	0	122	51	0	1	0	52	375
16:30	0	114	55	0	169	60	0	9	0	69	9	94	0	0	103	44	0	3	0	47	388
16:45	0	101	35	0	136	59	1	7	0	67	7	89	0	0	96	61	0	3	0	64	363
Total Volume	0	428	165	0	593	210	7	37	0	254	25	391	0	0	416	210	0	9	0	219	1482
% App. Total	0	72.2	27.8	0		82.7	2.8	14.6	0		6	94	0	0		95.9	0	4.1	0		
PHF	.000	.939	.750	.000	.877	.875	.583	.771	.000	.920	.694	.857	.000	.000	.852	.861	.000	.750	.000	.855	.955

