



MINNESOTA DEPT OF TRANSPORTATION

TRAFFIC DATA COLLECTION - METRO

TH-52 at Butler Ave., East Ramp
 Ref.Pt.: 128.048
 JAMAR #D4-3365 CH
 TURN MOVEMENT COUNT

File Name : TH-52 at Butler Ave E RAMP 2009
 Site Code : 00000000
 Start Date : 6/16/2009
 Page No : 1

Groups Printed- Cars & Trucks

Start Time	Ramp to TH-52 NB Southbound				Butler Ave. Westbound				Ramp from TH-52 NB Northbound				Butler Ave. Eastbound				Int. Total
	Left	Thru	Right	Peds	Left	Thru	Right	Peds	Left	Thru	Right	Peds	Left	Thru	Right	Peds	
06:00	0	0	0	0	0	11	5	0	10	0	1	0	47	1	0	0	75
06:15	0	0	0	0	0	11	8	0	7	0	0	0	31	7	0	1	65
06:30	0	0	0	0	0	11	18	0	11	1	1	0	53	10	0	0	105
06:45	0	0	0	0	0	13	12	0	18	1	3	0	40	11	0	0	98
Total	0	0	0	0	0	46	43	0	46	2	5	0	171	29	0	1	343
07:00	0	0	0	0	0	20	14	0	28	0	3	0	43	8	0	1	117
07:15	0	0	0	0	0	22	7	0	26	0	4	0	46	19	0	0	124
07:30	0	0	0	0	0	21	11	0	23	0	0	0	43	14	0	0	112
07:45	0	0	0	0	0	26	12	0	34	0	5	0	41	16	0	0	134
Total	0	0	0	0	0	89	44	0	111	0	12	0	173	57	0	1	487
08:00	0	0	0	0	0	8	5	0	28	0	1	0	39	2	0	0	83
08:15	0	0	0	0	0	13	11	0	22	0	1	0	31	16	0	0	94
08:30	0	0	0	0	0	18	10	0	35	0	2	0	33	18	0	0	116
08:45	0	0	0	0	0	18	2	0	30	0	3	0	37	17	0	0	107
Total	0	0	0	0	0	57	28	0	115	0	7	0	140	53	0	0	400
15:00	0	0	0	0	0	23	6	2	35	0	14	0	57	35	0	0	172
15:15	0	0	0	0	0	28	3	0	40	0	10	0	45	31	0	0	157
15:30	0	0	0	0	0	34	5	0	42	0	17	0	46	25	0	0	169
15:45	0	0	0	0	0	23	6	1	54	0	10	0	42	27	0	0	163
Total	0	0	0	0	0	108	20	3	171	0	51	0	190	118	0	0	661
16:00	0	0	0	0	0	26	7	0	50	0	19	0	55	28	0	0	185
16:15	0	0	0	0	0	24	4	1	60	0	14	0	51	22	0	0	176
16:30	0	0	0	0	0	32	11	0	39	0	13	0	44	40	0	0	179
16:45	0	0	0	0	0	28	11	0	57	0	16	0	33	36	0	0	181
Total	0	0	0	0	0	110	33	1	206	0	62	0	183	126	0	0	721
17:00	0	0	0	0	0	28	13	0	37	0	14	0	40	36	0	0	168
17:15	0	0	0	0	0	37	2	0	46	0	13	0	36	36	0	0	170
17:30	0	0	0	0	0	19	11	0	52	0	8	0	56	30	0	1	177
17:45	0	0	0	0	0	23	5	2	49	0	17	0	33	27	1	0	157
Total	0	0	0	0	0	107	31	2	184	0	52	0	165	129	1	1	672
Grand Total	0	0	0	0	0	517	199	6	833	2	189	0	1022	512	1	3	3284
Apprch %	0	0	0	0	0	71.6	27.6	0.8	81.3	0.2	18.5	0	66.4	33.3	0.1	0.2	
Total %	0	0	0	0	0	15.7	6.1	0.2	25.4	0.1	5.8	0	31.1	15.6	0	0.1	



MINNESOTA DEPT OF TRANSPORTATION

TRAFFIC DATA COLLECTION - METRO

TH-52 at Butler Ave., East Ramp
 Ref.Pt.: 128.048
 JAMAR #D4-3365 CH
 TURN MOVEMENT COUNT

File Name : TH-52 at Butler Ave E RAMP 2009
 Site Code : 00000000
 Start Date : 6/16/2009
 Page No : 2

Start Time	Ramp to TH-52 NB Southbound					Butler Ave. Westbound					Ramp from TH-52 NB Northbound					Butler Ave. Eastbound					Int. Total
	Left	Thru	Right	Peds	App. Total	Left	Thru	Right	Peds	App. Total	Left	Thru	Right	Peds	App. Total	Left	Thru	Right	Peds	App. Total	
Peak Hour Analysis From 06:00 to 08:45 - Peak 1 of 1																					
Peak Hour for Entire Intersection Begins at 07:00																					
07:00	0	0	0	0	0	0	20	14	0	34	28	0	3	0	31	43	8	0	1	52	117
07:15	0	0	0	0	0	0	22	7	0	29	26	0	4	0	30	46	19	0	0	65	124
07:30	0	0	0	0	0	0	21	11	0	32	23	0	0	0	23	43	14	0	0	57	112
07:45	0	0	0	0	0	0	26	12	0	38	34	0	5	0	39	41	16	0	0	57	134
Total Volume	0	0	0	0	0	0	89	44	0	133	111	0	12	0	123	173	57	0	1	231	487
% App. Total	0	0	0	0	0	0	66.9	33.1	0		90.2	0	9.8	0		74.9	24.7	0	0.4		
PHF	.000	.000	.000	.000	.000	.000	.856	.786	.000	.875	.816	.000	.600	.000	.788	.940	.750	.000	.250	.888	.909

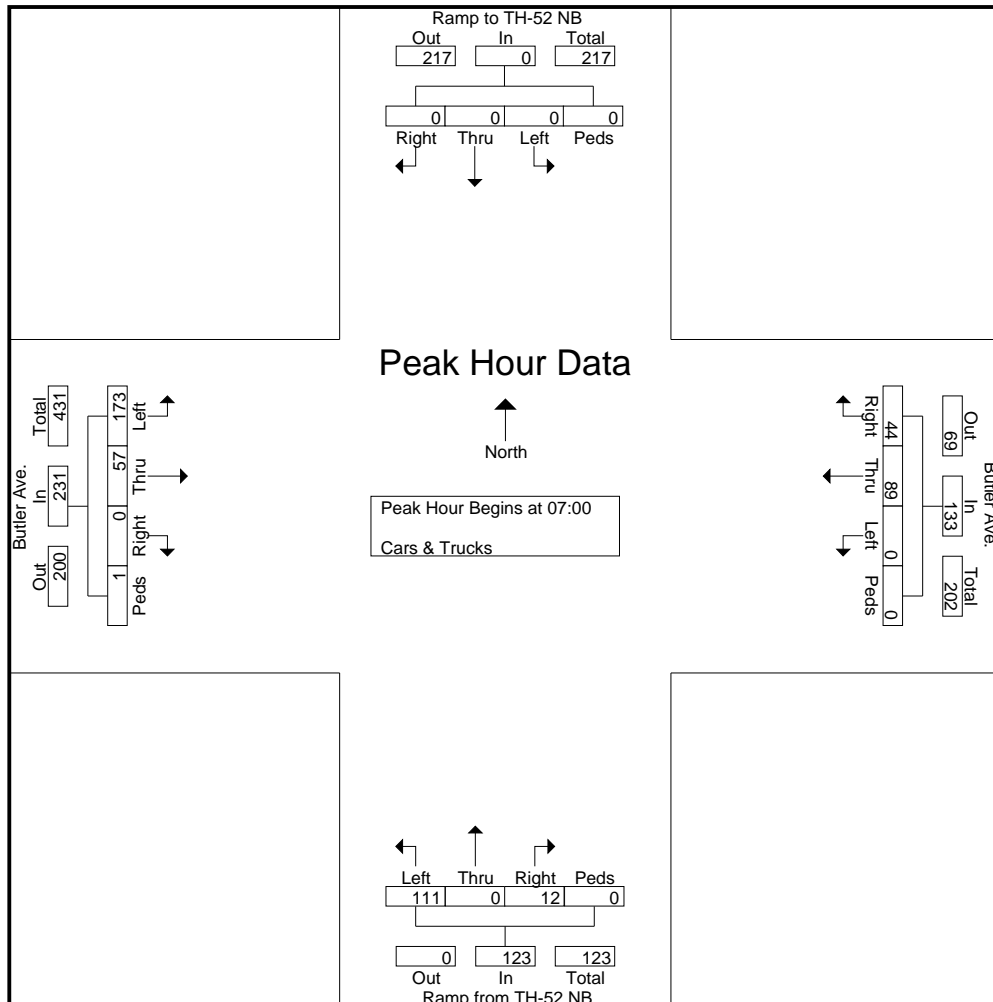



MINNESOTA DEPT OF TRANSPORTATION

TRAFFIC DATA COLLECTION - METRO

TH-52 at Butler Ave., East Ramp
 Ref.Pt.: 128.048
 JAMAR #D4-3365 CH
 TURN MOVEMENT COUNT

File Name : TH-52 at Butler Ave E RAMP 2009
 Site Code : 00000000
 Start Date : 6/16/2009
 Page No : 3

Start Time	Ramp to TH-52 NB Southbound					Butler Ave. Westbound					Ramp from TH-52 NB Northbound					Butler Ave. Eastbound					Int. Total
	Left	Thru	Right	Peds	App. Total	Left	Thru	Right	Peds	App. Total	Left	Thru	Right	Peds	App. Total	Left	Thru	Right	Peds	App. Total	
Peak Hour Analysis From 15:00 to 17:45 - Peak 1 of 1																					
Peak Hour for Entire Intersection Begins at 16:00																					
16:00	0	0	0	0	0	0	26	7	0	33	50	0	19	0	69	55	28	0	0	83	185
16:15	0	0	0	0	0	0	24	4	1	29	60	0	14	0	74	51	22	0	0	73	176
16:30	0	0	0	0	0	0	32	11	0	43	39	0	13	0	52	44	40	0	0	84	179
16:45	0	0	0	0	0	0	28	11	0	39	57	0	16	0	73	33	36	0	0	69	181
Total Volume	0	0	0	0	0	0	110	33	1	144	206	0	62	0	268	183	126	0	0	309	721
% App. Total	0	0	0	0	0	0	76.4	22.9	0.7		76.9	0	23.1	0		59.2	40.8	0	0		
PHF	.000	.000	.000	.000	.000	.000	.859	.750	.250	.837	.858	.000	.816	.000	.905	.832	.788	.000	.000	.920	.974

