

Albeck Gerken, Inc

Transportation Engineers

Traffic Data Collection

TH-52 at Upper 55th St E, east ramps
 Inver Grove Heights
 Ref.Pt.: 124.735
 TURN MOVEMENT COUNT

File Name : 8 TH 52 East Ramp at Upper 55th St East
 Site Code : 8
 Start Date : 1/13/2012
 Page No : 1

Groups Printed- Cars - Heavy Vehicles

Start Time	Bishop Ave Southbound				Upper 55th St E Westbound				ramp from \ loop to TH-52 NB Northbound				Upper 55th St E Eastbound				Int. Total
	Left	Thru	Right	Peds	Left	Thru	Right	Peds	Left	Thru	Right	Peds	Left	Thru	Right	Peds	
06:00	0	24	1	0	28	22	7	0	2	6	3	0	13	15	10	0	131
06:15	8	21	5	0	32	14	9	0	6	4	3	0	14	20	23	0	159
06:30	4	21	12	0	31	25	14	0	6	5	9	0	11	31	29	0	198
06:45	2	20	6	0	36	31	12	0	18	12	9	0	16	37	23	0	222
Total	14	86	24	0	127	92	42	0	32	27	24	0	54	103	85	0	710
07:00	3	27	6	0	37	36	18	0	18	8	8	0	21	36	31	0	249
07:15	5	26	9	0	58	53	9	0	38	10	12	0	20	49	33	0	322
07:30	7	19	19	0	57	55	10	0	15	12	11	1	32	53	38	0	329
07:45	9	26	15	0	55	55	16	0	37	13	16	0	23	79	32	0	376
Total	24	98	49	0	207	199	53	0	108	43	47	1	96	217	134	0	1276
08:00	5	24	16	0	47	45	7	0	20	7	15	0	23	70	27	0	306
08:15	6	23	10	0	56	39	13	0	13	10	5	0	19	61	44	0	299
08:30	3	15	13	2	39	46	10	0	9	5	13	0	20	58	22	0	255
08:45	4	19	13	1	26	43	6	0	12	9	12	2	24	79	29	0	279
Total	18	81	52	3	168	173	36	0	54	31	45	2	86	268	122	0	1139
09:00	4	26	12	0	41	26	22	0	7	7	10	0	19	55	19	0	248
09:15	8	16	5	0	30	21	7	0	4	8	6	0	22	68	20	0	215
09:30	6	15	3	0	38	29	4	0	5	5	6	0	16	75	15	0	217
09:45	8	9	7	0	35	30	2	0	6	10	7	1	17	85	15	0	232
Total	26	66	27	0	144	106	35	0	22	30	29	1	74	283	69	0	912
10:00	7	22	10	0	35	33	6	0	3	9	6	0	18	65	15	0	229
10:15	4	12	7	0	33	38	13	2	9	7	12	0	15	49	18	0	219
10:30	7	17	10	2	33	36	9	0	3	6	10	0	16	72	18	0	239
10:45	8	10	8	0	32	40	6	0	6	3	7	0	20	89	21	0	250
Total	26	61	35	2	133	147	34	2	21	25	35	0	69	275	72	0	937
11:00	5	10	9	0	34	49	11	0	5	9	14	0	24	77	26	0	273
11:15	10	16	7	0	32	37	10	0	5	9	13	0	29	97	10	0	275
11:30	7	15	7	0	37	49	16	0	0	9	20	0	19	76	20	0	275
11:45	11	14	7	0	35	43	9	0	9	8	14	0	24	114	12	0	300
Total	33	55	30	0	138	178	46	0	19	35	61	0	96	364	68	0	1123
12:00	8	17	9	0	54	48	17	0	12	10	12	0	28	104	20	0	339
12:15	9	6	19	0	44	57	14	0	10	3	14	0	34	78	15	0	303
12:30	4	14	11	0	68	58	12	0	8	6	13	0	19	84	17	0	314
12:45	7	19	16	0	40	52	10	0	12	12	9	0	19	75	18	0	289
Total	28	56	55	0	206	215	53	0	42	31	48	0	100	341	70	0	1245
13:00	6	12	15	1	46	38	15	0	10	7	5	0	19	77	18	0	269
13:15	16	24	9	0	46	41	14	0	11	7	11	0	21	82	23	0	305
13:30	11	15	18	0	44	51	9	0	8	10	13	0	29	78	16	0	302
13:45	11	28	21	0	36	53	17	0	6	10	13	0	28	91	26	0	340
Total	44	79	63	1	172	183	55	0	35	34	42	0	97	328	83	0	1216
14:00	5	19	5	0	29	51	7	0	9	6	5	0	18	101	29	0	284
14:15	9	17	7	3	43	55	16	0	6	14	7	0	19	102	25	0	323
14:30	8	8	8	0	50	56	8	0	7	11	11	0	14	116	27	0	324
14:45	13	24	8	0	44	43	14	0	10	13	10	0	29	120	18	0	346
Total	35	68	28	3	166	205	45	0	32	44	33	0	80	439	99	0	1277
15:00	9	25	11	1	36	58	8	0	11	13	8	0	28	81	27	0	316
15:15	6	12	12	1	40	45	15	0	14	5	10	0	19	116	40	0	335
15:30	8	18	6	1	38	56	17	0	12	9	7	0	37	117	44	0	370
15:45	20	24	10	2	42	59	21	0	8	9	13	1	34	146	32	0	421
Total	43	79	39	5	156	218	61	0	45	36	38	1	118	460	143	0	1442

Albeck Gerken, Inc

Transportation Engineers

Traffic Data Collection

TH-52 at Upper 55th St E, east ramps
 Inver Grove Heights
 Ref.Pt.: 124.735
 TURN MOVEMENT COUNT

File Name : 8 TH 52 East Ramp at Upper 55th St East
 Site Code : 8
 Start Date : 1/13/2012
 Page No : 2

Groups Printed- Cars - Heavy Vehicles

Start Time	Bishop Ave Southbound				Upper 55th St E Westbound				ramp from \ loop to TH-52 NB Northbound				Upper 55th St E Eastbound				Int. Total
	Left	Thru	Right	Peds	Left	Thru	Right	Peds	Left	Thru	Right	Peds	Left	Thru	Right	Peds	
16:00	11	27	11	0	39	48	13	0	10	11	9	0	32	137	70	0	418
16:15	8	26	13	1	38	65	14	0	7	10	11	0	29	124	45	0	391
16:30	13	20	11	0	46	42	14	0	12	18	9	0	34	165	78	0	462
16:45	11	24	15	0	52	51	17	0	13	17	9	0	43	184	54	0	490
Total	43	97	50	1	175	206	58	0	42	56	38	0	138	610	247	0	1761
17:00	13	22	9	0	55	58	13	0	11	19	12	0	51	168	73	0	504
17:15	15	14	10	3	48	46	24	0	11	19	18	1	40	142	41	0	432
17:30	14	23	5	1	53	60	18	0	18	16	19	0	50	146	39	0	462
17:45	15	18	13	0	41	49	10	0	13	11	13	1	41	113	28	0	366
Total	57	77	37	4	197	213	65	0	53	65	62	2	182	569	181	0	1764
18:00	15	19	12	0	49	66	26	0	10	22	20	0	25	110	17	0	391
18:15	9	26	19	0	47	45	10	0	3	17	15	0	29	104	25	0	349
18:30	16	18	16	0	30	36	14	0	15	17	14	0	18	84	21	0	299
18:45	13	18	9	1	31	42	20	0	5	8	14	0	24	82	22	2	291
Total	53	81	56	1	157	189	70	0	33	64	63	0	96	380	85	2	1330
Grand Total	444	984	545	20	2146	2324	653	2	538	521	565	7	1286	4637	1458	2	16132
Apprch %	22.3	49.4	27.3	1	41.9	45.3	12.7	0	33	31.9	34.6	0.4	17.4	62.8	19.7	0	
Total %	2.8	6.1	3.4	0.1	13.3	14.4	4	0	3.3	3.2	3.5	0	8	28.7	9	0	
Cars	430	919	530	20	1974	2230	628	2	517	493	528	6	1235	4389	1418	2	15321
% Cars	96.8	93.4	97.2	100	92	96	96.2	100	96.1	94.6	93.5	85.7	96	94.7	97.3	100	95
Heavy Vehicles	14	65	15	0	172	94	25	0	21	28	37	1	51	248	40	0	811
% Heavy Vehicles	3.2	6.6	2.8	0	8	4	3.8	0	3.9	5.4	6.5	14.3	4	5.3	2.7	0	5

Albeck Gerken, Inc

Transportation Engineers

Traffic Data Collection

TH-52 at Upper 55th St E, east ramps
 Inver Grove Heights
 Ref.Pt.: 124.735
 TURN MOVEMENT COUNT

File Name : 8 TH 52 East Ramp at Upper 55th St East
 Site Code : 8
 Start Date : 1/13/2012
 Page No : 3

Start Time	Bishop Ave Southbound					Upper 55th St E Westbound					ramp from \ loop to TH-52 NB Northbound					Upper 55th St E Eastbound					Int. Total
	Left	Thru	Right	Peds	App. Total	Left	Thru	Right	Peds	App. Total	Left	Thru	Right	Peds	App. Total	Left	Thru	Right	Peds	App. Total	
Peak Hour Analysis From 06:00 to 09:00 - Peak 1 of 1																					
Peak Hour for Entire Intersection Begins at 07:15																					
07:15	5	26	9	0	40	58	53	9	0	120	38	10	12	0	60	20	49	33	0	102	322
07:30	7	19	19	0	45	57	55	10	0	122	15	12	11	1	39	32	53	38	0	123	329
07:45	9	26	15	0	50	55	55	16	0	126	37	13	16	0	66	23	79	32	0	134	376
08:00	5	24	16	0	45	47	45	7	0	99	20	7	15	0	42	23	70	27	0	120	306
Total Volume	26	95	59	0	180	217	208	42	0	467	110	42	54	1	207	98	251	130	0	479	1333
% App. Total	14.4	52.8	32.8	0		46.5	44.5	9	0		53.1	20.3	26.1	0.5		20.5	52.4	27.1	0		
PHF	.722	.913	.776	.000	.900	.935	.945	.656	.000	.927	.724	.808	.844	.250	.784	.766	.794	.855	.000	.894	.886

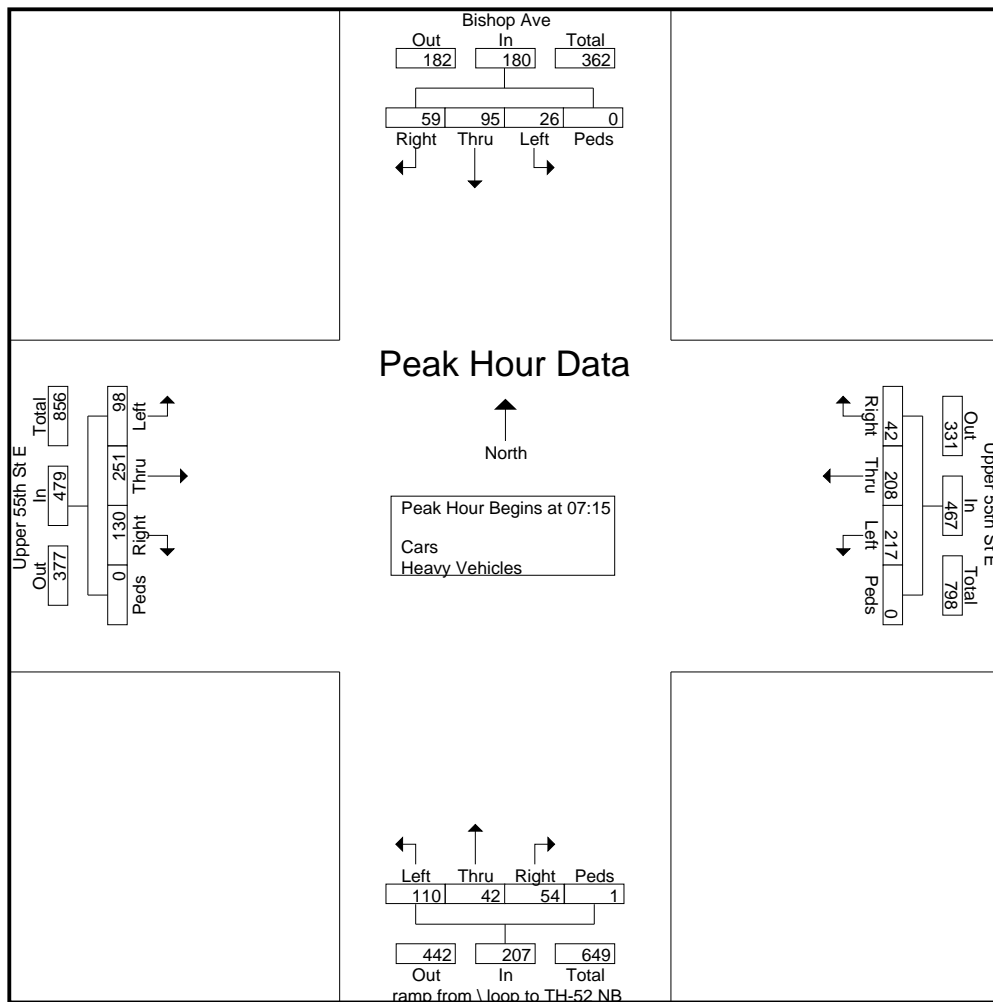

Albeck Gerken, Inc

Transportation Engineers

Traffic Data Collection

TH-52 at Upper 55th St E, east ramps
 Inver Grove Heights
 Ref.Pt.: 124.735
 TURN MOVEMENT COUNT

File Name : 8 TH 52 East Ramp at Upper 55th St East
 Site Code : 8
 Start Date : 1/13/2012
 Page No : 4

Start Time	Bishop Ave Southbound					Upper 55th St E Westbound					ramp from \ loop to TH-52 NB Northbound					Upper 55th St E Eastbound					Int. Total
	Left	Thru	Right	Peds	App. Total	Left	Thru	Right	Peds	App. Total	Left	Thru	Right	Peds	App. Total	Left	Thru	Right	Peds	App. Total	
Peak Hour Analysis From 15:00 to 18:45 - Peak 1 of 1																					
Peak Hour for Entire Intersection Begins at 16:30																					
16:30	13	20	11	0	44	46	42	14	0	102	12	18	9	0	39	34	165	78	0	277	462
16:45	11	24	15	0	50	52	51	17	0	120	13	17	9	0	39	43	184	54	0	281	490
17:00	13	22	9	0	44	55	58	13	0	126	11	19	12	0	42	51	168	73	0	292	504
17:15	15	14	10	3	42	48	46	24	0	118	11	19	18	1	49	40	142	41	0	223	432
Total Volume	52	80	45	3	180	201	197	68	0	466	47	73	48	1	169	168	659	246	0	1073	1888
% App. Total	28.9	44.4	25	1.7		43.1	42.3	14.6	0		27.8	43.2	28.4	0.6		15.7	61.4	22.9	0		
PHF	.867	.833	.750	.250	.900	.914	.849	.708	.000	.925	.904	.961	.667	.250	.862	.824	.895	.788	.000	.919	.937

