

ALLIANT ENGINEERING, INC.

733 S Marquette Ave #700, Minneapolis, MN 55402

Intersection: Upper 55th Street & Bishop Avenue - TH 52 East Ramp
 Date: 9/19/2024
 Duration: 0600-1900

Site Code: 421
 Ref Pt: N/A
 Page No: 2 of 4

All Vehicles (Cars & Trucks) Printed

Start Time	Bishop Avenue Southbound						Upper 55th Street Westbound						TH 52 East Ramp Northbound						Upper 55th Street Eastbound						Int. Veh. Total	Int. Ped/Bike Total
	U-Turn	Left	Thru	Right	App. Total	Peds/Bikes	U-Turn	Left	Thru	Right	App. Total	Peds/Bikes	U-Turn	Left	Thru	Right	App. Total	Peds/Bikes	U-Turn	Left	Thru	Right	App. Total	Peds/Bikes		
7:30	--	5	15	18	38	1	--	51	56	10	117	--	--	27	7	13	47	--	--	23	72	34	129	--	331	1
7:45	--	7	24	27	58	1	--	58	56	5	119	--	--	31	14	30	75	--	--	22	80	23	125	--	377	1
8:00	--	4	14	8	26	--	--	50	35	8	93	--	--	13	5	9	27	--	1	19	59	19	98	--	244	--
8:15	--	6	11	4	21	--	--	51	42	10	103	--	--	16	5	14	35	--	--	14	80	18	112	--	271	--
Hour Total	--	22	64	57	143	2	--	210	189	33	432	--	--	87	31	66	184	--	1	78	291	94	464	--	1223	2
% of App.	0.0%	15.4%	44.8%	39.9%			0.0%	48.6%	43.8%	7.6%			0.0%	47.3%	16.8%	35.9%			0.2%	16.8%	62.7%	20.3%				
% of Total	0.0%	1.8%	5.2%	4.7%	11.7%	100.0%	0.0%	17.2%	15.5%	2.7%	35.3%	0.0%	0.0%	7.1%	2.5%	5.4%	15.0%	0.0%	0.1%	6.4%	23.8%	7.7%	37.9%	0.0%		
Cars Total	--	22	59	57	138	2	--	190	183	32	405	--	--	85	30	63	178	--	1	74	281	93	449	--	1170	2
Cars % of Movement	0.0%	100%	92.2%	100%	96.5%	100.0%	0.0%	90.5%	96.8%	97.0%	93.8%	0.0%	0.0%	97.7%	96.8%	95.5%	96.7%	0.0%	100%	94.9%	96.6%	98.9%	96.8%	0.0%	95.7%	
Trucks Total	--	--	5	--	5	--	--	20	6	1	27	--	--	2	1	3	6	--	--	4	10	1	15	--	53	--
Trucks % of Movement	0.0%	0.0%	7.8%	0.0%	3.5%	--	0.0%	9.5%	3.2%	3.0%	6.3%	--	0.0%	2.3%	3.2%	4.5%	3.3%	--	0.0%	5.1%	3.4%	1.1%	3.2%	--	4.3%	

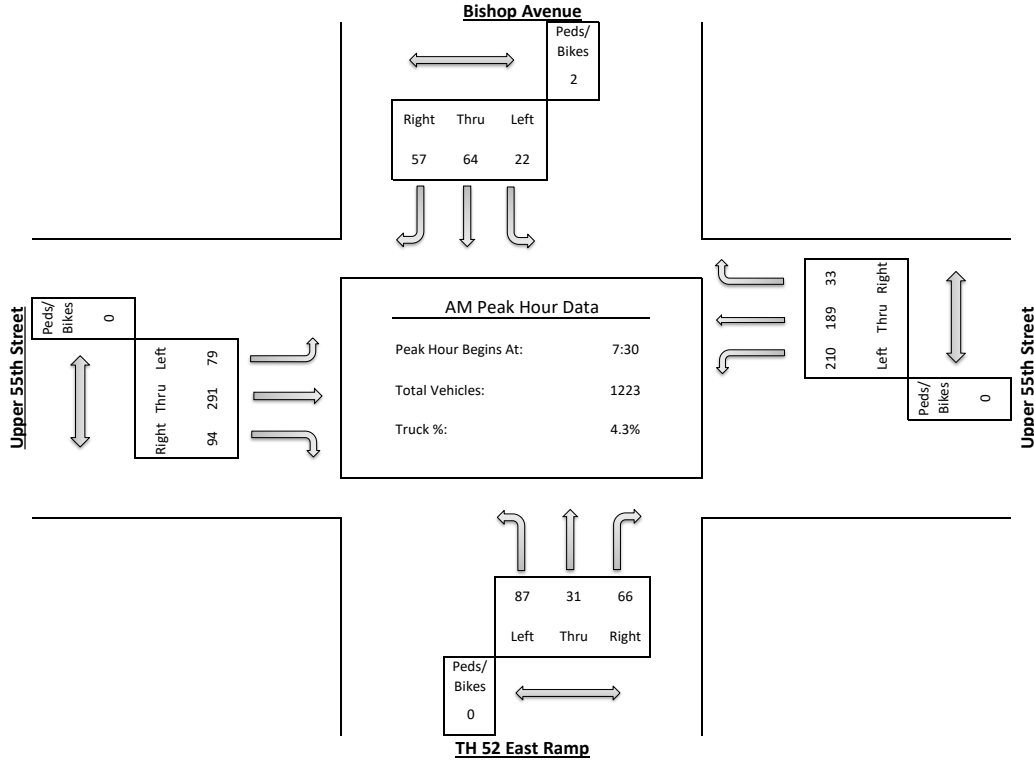

ALLIANT ENGINEERING, INC.

733 S Marquette Ave #700, Minneapolis, MN 55402

Intersection: Upper 55th Street & Bishop Avenue - TH 52 East Ramp
 Date: 9/19/2024
 Duration: 0600-1900

Site Code: 421
 Ref Pt: N/A
 Page No: 3 of 4

All Vehicles (Cars & Trucks) Printed

Start Time	Bishop Avenue Southbound						Upper 55th Street Westbound						TH 52 East Ramp Northbound						Upper 55th Street Eastbound						Int. Veh. Total	Int. Ped/Bike Total
	U-Turn	Left	Thru	Right	App. Total	Peds/Bikes	U-Turn	Left	Thru	Right	App. Total	Peds/Bikes	U-Turn	Left	Thru	Right	App. Total	Peds/Bikes	U-Turn	Left	Thru	Right	App. Total	Peds/Bikes		
12:00	--	1	18	9	28	2	--	51	51	12	114	--	--	6	10	17	33	--	1	15	102	16	134	--	309	2
12:15	--	12	8	12	32	--	--	59	60	8	127	--	--	4	4	16	24	--	--	24	113	10	147	--	330	--
12:30	--	6	12	14	32	1	--	64	49	5	118	--	--	6	5	10	21	--	--	19	101	17	137	--	308	1
12:45	--	6	13	12	31	1	--	59	53	12	124	--	--	4	5	11	20	--	--	25	104	16	145	--	320	1
Hour Total	--	25	51	47	123	4	--	233	213	37	483	--	--	20	24	54	98	--	1	83	420	59	563	--	1267	4
% of App.	0.0%	20.3%	41.5%	38.2%			0.0%	48.2%	44.1%	7.7%			0.0%	20.4%	24.5%	55.1%			0.2%	14.7%	74.6%	10.5%				
% of Total	0.0%	2.0%	4.0%	3.7%	9.7%	100.0%	0.0%	18.4%	16.8%	2.9%	38.1%	0.0%	0.0%	1.6%	1.9%	4.3%	7.7%	0.0%	0.1%	6.6%	33.1%	4.7%	44.4%	0.0%		
Cars Total	--	25	49	47	121	3	--	223	211	37	471	--	--	17	24	54	95	--	1	82	405	57	545	--	1232	3
Cars % of Movement	0.0%	100%	96.1%	100%	98.4%	100.0%	0.0%	95.7%	99.1%	100%	97.5%	0.0%	0.0%	85.0%	100%	100%	96.9%	0.0%	100%	98.8%	96.4%	96.6%	96.8%	0.0%	97.2%	
Trucks Total	--	--	2	--	2	1	--	10	2	--	12	--	--	3	--	--	3	--	--	1	15	2	18	--	35	1
Trucks % of Movement	0.0%	0.0%	3.9%	0.0%	1.6%	100.0%	0.0%	4.3%	0.9%	0.0%	2.5%	0.0%	0.0%	15.0%	0.0%	0.0%	3.1%	0.0%	0.0%	1.2%	3.6%	3.4%	3.2%	0.0%	2.8%	

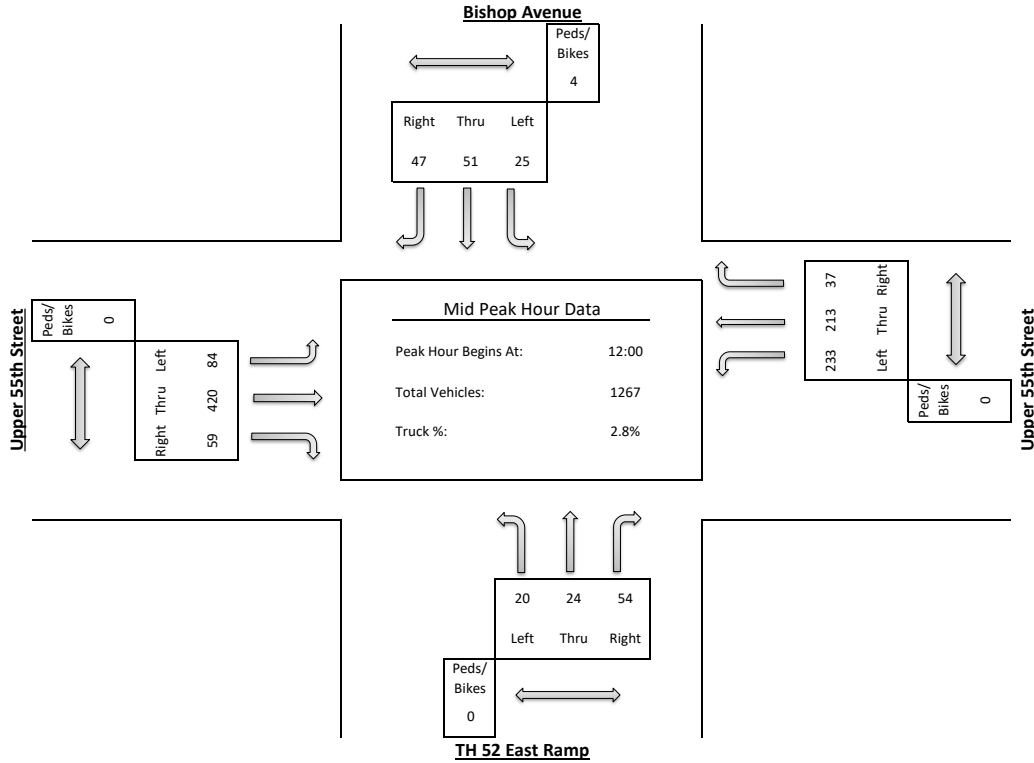

ALLIANT ENGINEERING, INC.

733 S Marquette Ave #700, Minneapolis, MN 55402

Intersection: Upper 55th Street & Bishop Avenue - TH 52 East Ramp
 Date: 9/19/2024
 Duration: 0600-1900

Site Code: 421
 Ref Pt: N/A
 Page No: 4 of 4

All Vehicles (Cars & Trucks) Printed

Start Time	Bishop Avenue Southbound						Upper 55th Street Westbound						TH 52 East Ramp Northbound						Upper 55th Street Eastbound						Int. Veh. Total	Int. Ped/Bike Total
	U-Turn	Left	Thru	Right	App. Total	Peds/Bikes	U-Turn	Left	Thru	Right	App. Total	Peds/Bikes	U-Turn	Left	Thru	Right	App. Total	Peds/Bikes	U-Turn	Left	Thru	Right	App. Total	Peds/Bikes		
16:15	--	9	16	9	34	--	--	43	55	13	111	--	--	7	10	12	29	--	--	35	152	29	216	--	390	--
16:30	--	8	21	11	40	--	--	70	51	18	139	--	--	8	8	16	32	--	--	39	147	35	221	--	432	--
16:45	--	9	13	8	30	2	--	67	51	15	133	--	1	10	14	27	52	--	--	33	157	26	216	--	431	2
17:00	--	13	26	16	55	--	--	68	61	13	142	--	--	9	10	17	36	--	--	35	129	30	194	--	427	--
Hour Total	--	39	76	44	159	2	--	248	218	59	525	--	1	34	42	72	149	--	--	142	585	120	847	--	1680	2
% of App.	0.0%	24.5%	47.8%	27.7%			0.0%	47.2%	41.5%	11.2%			0.7%	22.8%	28.2%	48.3%			0.0%	16.8%	69.1%	14.2%				
% of Total	0.0%	2.3%	4.5%	2.6%	9.5%	100.0%	0.0%	14.8%	13.0%	3.5%	31.3%	0.0%	0.1%	2.0%	2.5%	4.3%	8.9%	0.0%	0.0%	8.5%	34.8%	7.1%	50.4%	0.0%		
Cars Total	--	39	76	43	158	--	--	244	215	59	518	--	1	34	42	70	147	--	--	141	580	119	840	--	1663	--
Cars % of Movement	0.0%	100%	100%	97.7%	99.4%	--	0.0%	98.4%	98.6%	100%	98.7%	--	100%	100%	100%	97.2%	98.7%	--	0.0%	99.3%	99.1%	99.2%	99.2%	--	99.0%	
Trucks Total	--	--	--	1	1	2	--	4	3	--	7	--	--	--	--	2	2	--	--	1	5	1	7	--	17	2
Trucks % of Movement	0.0%	0.0%	0.0%	2.3%	0.6%	100.0%	0.0%	1.6%	1.4%	0.0%	1.3%	0.0%	0.0%	0.0%	0.0%	2.8%	1.3%	0.0%	0.0%	0.7%	0.9%	0.8%	0.8%	0.0%	1.0%	

