

ALLIANT ENGINEERING, INC.

733 S Marquette Ave #700, Minneapolis, MN 55402

Intersection: Upper 55th Street & Blaine Avenue
 Date: 9/21/2024
 Duration: 0500-2300

Site Code: 422
 Ref Pt: N/A
 Page No: 1 of 5

All Vehicles (Cars & Trucks) Printed

Start Time	Blaine Avenue Southbound						Upper 55th Street Westbound						Blaine Avenue Northbound						Upper 55th Street Eastbound						Int. Veh. Total	Int. Ped/ Bike Total	
	U-Turn	Left	Thru	Right	App. Total	Peds/ Bikes	U-Turn	Left	Thru	Right	App. Total	Peds/ Bikes	U-Turn	Left	Thru	Right	App. Total	Peds/ Bikes	U-Turn	Left	Thru	Right	App. Total	Peds/ Bikes			
5:00	--	--	1	--	1	--	--	--	4	--	4	--	--	--	--	--	0	--	--	--	5	--	5	--	10	--	
5:15	--	1	--	3	4	--	--	--	5	1	6	--	--	1	3	1	5	--	--	--	6	--	6	--	21	--	
5:30	--	--	1	1	2	--	--	--	10	--	10	--	--	1	--	--	1	--	--	--	2	2	4	--	17	--	
5:45	--	--	--	--	0	--	--	--	10	--	10	--	--	2	--	--	2	--	--	--	2	1	10	--	22	--	
Hour Total	--	1	2	4	7	--	--	--	29	1	30	--	--	4	3	1	8	--	--	2	20	3	25	--	70	--	
6:00	--	1	--	4	5	--	--	--	7	2	9	--	--	1	1	--	2	--	--	2	6	1	9	--	25	--	
6:15	--	1	--	4	5	--	--	2	12	1	15	--	--	4	2	--	6	--	--	5	6	--	11	--	37	--	
6:30	--	--	--	5	5	1	--	--	12	1	13	--	--	8	5	1	14	--	--	4	9	2	15	--	47	1	
6:45	--	--	1	4	5	3	--	--	11	1	12	--	--	6	2	1	9	--	--	6	17	4	27	--	53	3	
Hour Total	--	2	1	17	20	4	--	2	42	5	49	--	--	19	10	2	31	--	--	17	38	7	62	--	162	4	
7:00	--	--	5	8	13	--	--	2	9	2	13	1	--	4	2	--	6	--	--	5	9	6	20	--	52	1	
7:15	--	--	1	8	9	1	--	--	12	1	13	1	--	4	1	2	7	--	--	6	8	5	19	--	48	2	
7:30	--	5	4	5	14	--	--	3	23	5	31	1	--	7	5	1	13	--	--	10	16	7	33	--	91	1	
7:45	--	4	5	8	17	2	--	1	20	5	26	1	--	9	5	--	14	--	--	1	13	21	6	41	--	98	3
Hour Total	--	9	15	29	53	3	--	6	64	13	83	4	--	24	13	3	40	--	--	1	34	54	24	113	--	289	7
8:00	--	6	5	7	18	3	--	2	38	4	44	2	--	11	2	2	15	--	--	18	16	2	36	--	113	5	
8:15	--	5	5	16	26	2	--	5	27	17	49	--	--	7	5	1	13	--	--	23	25	5	53	--	141	2	
8:30	--	9	9	12	30	--	--	--	53	8	61	--	--	7	6	3	16	--	--	25	21	6	52	--	159	--	
8:45	--	11	8	35	54	--	--	2	42	10	54	--	--	10	12	2	24	--	--	29	34	16	79	--	211	--	
Hour Total	--	31	27	70	128	5	--	9	160	39	208	2	--	35	25	8	68	--	--	95	96	29	220	--	624	7	
9:00	--	4	9	30	43	--	--	2	38	9	49	--	--	8	15	3	26	--	--	31	29	7	67	--	185	--	
9:15	--	7	8	29	44	1	1	--	38	6	45	--	--	11	4	3	18	--	--	37	33	11	81	1	188	2	
9:30	--	5	8	39	52	--	--	2	50	10	62	--	--	9	7	1	17	1	--	39	39	12	90	--	221	1	
9:45	--	11	13	44	68	--	--	3	56	6	65	1	--	19	11	3	33	--	--	37	53	8	98	--	264	1	
Hour Total	--	27	38	142	207	1	1	7	182	31	221	1	--	47	37	10	94	1	--	144	154	38	336	1	858	4	
10:00	--	7	9	35	51	--	--	4	45	8	57	--	--	18	6	6	30	--	--	33	37	14	84	--	222	--	
10:15	1	5	13	39	58	--	--	1	53	17	71	1	--	9	13	--	22	--	1	39	61	14	115	--	266	1	
10:30	--	9	8	41	58	--	--	4	43	18	65	--	--	10	9	6	25	1	--	40	60	12	112	--	260	1	
10:45	--	12	14	36	62	1	--	4	48	18	70	--	--	12	13	2	27	--	--	55	56	13	124	--	283	1	
Hour Total	1	33	44	151	229	1	--	13	189	61	263	1	--	49	41	14	104	1	--	1	167	214	53	435	--	1031	3
11:00	--	7	9	28	44	1	--	6	60	17	83	--	--	15	22	3	40	--	--	45	53	22	120	--	287	1	
11:15	--	5	17	42	64	--	--	3	47	16	66	--	--	21	11	6	38	--	--	44	38	28	110	--	278	--	
11:30	--	12	10	50	72	2	--	3	38	12	53	2	--	17	14	5	36	--	--	55	58	24	137	--	298	4	
11:45	--	4	17	54	75	2	--	5	39	9	53	--	--	19	20	7	46	--	--	1	38	49	27	115	--	289	2
Hour Total	--	28	53	174	255	5	--	17	184	54	255	2	--	72	67	21	160	--	--	1	182	198	101	482	--	1152	7
12:00	--	11	20	58	89	2	--	4	47	12	63	--	--	19	21	13	53	3	--	45	43	27	115	--	320	5	
12:15	--	8	22	46	76	--	--	5	48	11	64	--	--	16	24	5	45	--	--	63	57	31	151	--	336	--	
12:30	1	13	12	50	76	--	1	2	44	6	53	--	--	16	14	4	34	--	--	41	43	21	105	--	268	--	
12:45	--	6	15	54	75	--	--	5	51	7	63	--	--	24	18	6	48	--	--	47	52	40	139	--	325	--	
Hour Total	1	38	69	208	316	2	1	16	190	36	243	--	--	75	77	28	180	3	--	196	195	119	510	--	1249	5	
13:00	--	10	14	49	73	--	--	8	54	16	78	--	--	23	9	2	34	--	--	41	57	23	121	--	306	--	
13:15	--	12	15	52	79	--	--	6	60	15	81	1	--	19	15	11	45	--	--	60	51	24	135	--	340	1	
13:30	--	9	12	48	69	2	--	1	54	14	69	1	--	18	22	9	49	--	--	41	52	29	122	--	309	3	
13:45	--	10	15	57	82	1	--	3	47	18	68	1	--	8	23	9	40	--	--	39	52	21	112	--	302	2	
Hour Total	--	41	56	206	303	3	--	18	215	63	296	3	--	68	69	31	168	--	--	--	181	212	97	490	--	1257	6

ALLIANT ENGINEERING, INC.

733 S Marquette Ave #700, Minneapolis, MN 55402

Intersection: Upper 55th Street & Blaine Avenue
Date: 9/21/2024
Duration: 0500-2300

Site Code: 422
Ref Pt: N/A
Page No: 2 of 5

All Vehicles (Cars & Trucks) Printed

Table with columns for Start Time, Blaine Avenue Southbound (U-Turn, Left, Thru, Right, App. Total, Peds/Bikes), Upper 55th Street Westbound (U-Turn, Left, Thru, Right, App. Total, Peds/Bikes), Blaine Avenue Northbound (U-Turn, Left, Thru, Right, App. Total, Peds/Bikes), Upper 55th Street Eastbound (U-Turn, Left, Thru, Right, App. Total, Peds/Bikes), Int. Veh. Total, and Int. Ped/Bike Total. Rows include hourly data and grand totals for all approaches.

ALLIANT ENGINEERING, INC.

733 S Marquette Ave #700, Minneapolis, MN 55402

Intersection: Upper 55th Street & Blaine Avenue
 Date: 9/21/2024
 Duration: 0500-2300

Site Code: 422
 Ref Pt: N/A
 Page No: 3 of 5

All Vehicles (Cars & Trucks) Printed

Start Time	Blaine Avenue Southbound						Upper 55th Street Westbound						Blaine Avenue Northbound						Upper 55th Street Eastbound						Int. Veh. Total	Int. Ped/Bike Total
	U-Turn	Left	Thru	Right	App. Total	Peds/Bikes	U-Turn	Left	Thru	Right	App. Total	Peds/Bikes	U-Turn	Left	Thru	Right	App. Total	Peds/Bikes	U-Turn	Left	Thru	Right	App. Total	Peds/Bikes		
8:30	--	9	9	12	30	--	--	--	53	8	61	--	--	7	6	3	16	--	--	25	21	6	52	--	159	--
8:45	--	11	8	35	54	--	--	2	42	10	54	--	--	10	12	2	24	--	--	29	34	16	79	--	211	--
9:00	--	4	9	30	43	--	--	2	38	9	49	--	--	8	15	3	26	--	--	31	29	7	67	--	185	--
9:15	--	7	8	29	44	1	1	--	38	6	45	--	--	11	4	3	18	--	--	37	33	11	81	1	188	2
Hour Total	--	31	34	106	171	1	1	4	171	33	209	--	--	36	37	11	84	--	--	122	117	40	279	1	743	2
% of App.	0.0%	18.1%	19.9%	62.0%			0.5%	1.9%	81.8%	15.8%			0.0%	42.9%	44.0%	13.1%			0.0%	43.7%	41.9%	14.3%				
% of Total	0.0%	4.2%	4.6%	14.3%	23.0%	50.0%	0.1%	0.5%	23.0%	4.4%	28.1%	0.0%		0.0%	4.8%	5.0%	1.5%			0.0%	16.4%	15.7%	5.4%	37.6%	50.0%	
Cars Total	--	31	34	106	171	1	1	4	168	33	206	--	--	35	37	11	83	--	--	122	112	39	273	1	733	2
Cars % of Movement	0.0%	100%	100%	100%	100%	50.0%	100%	100%	98.2%	100%	98.6%	0.0%		0.0%	97.2%	100%	98.8%	0.0%		0.0%	100%	95.7%	97.5%	97.8%	50.0%	98.7%
Trucks Total	--	--	--	--	0	--	--	--	3	--	3	--	--	1	--	--	1	--	--	--	5	1	6	--	10	--
Trucks % of Movement	0.0%	0.0%	0.0%	0.0%	0.0%	--	0.0%	0.0%	1.8%	0.0%	1.4%	--		0.0%	2.8%	0.0%	1.2%	--		0.0%	0.0%	4.3%	2.5%	2.2%	--	1.3%

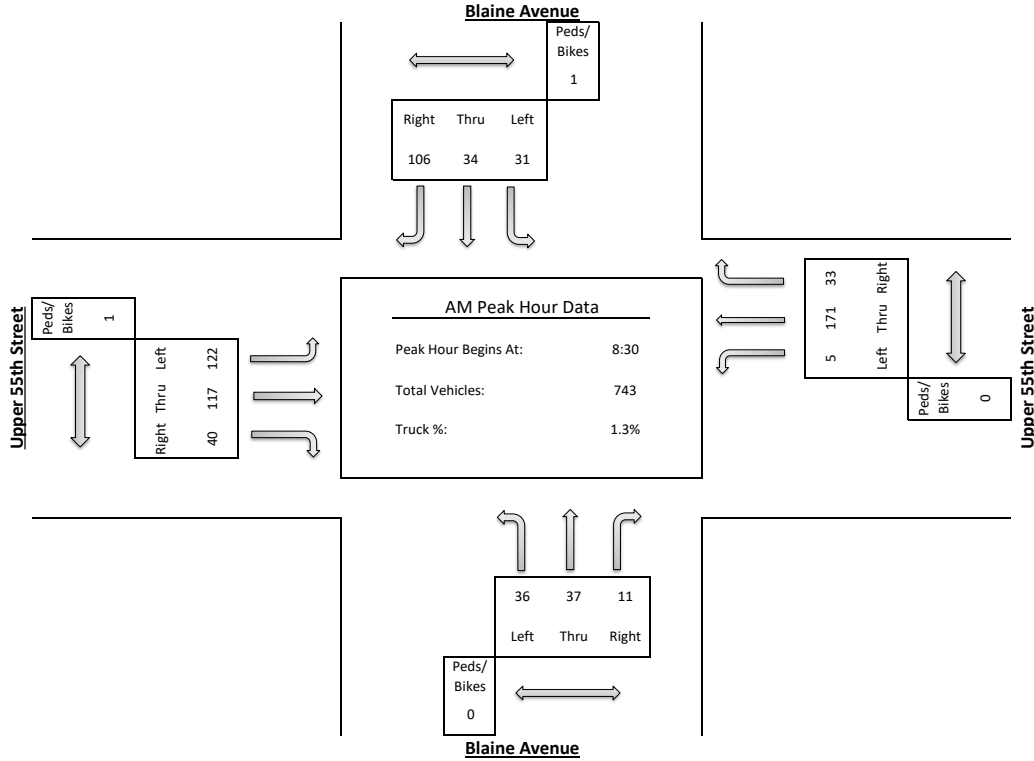

ALLIANT ENGINEERING, INC.

733 S Marquette Ave #700, Minneapolis, MN 55402

Intersection: Upper 55th Street & Blaine Avenue
 Date: 9/21/2024
 Duration: 0500-2300

Site Code: 422
 Ref Pt: N/A
 Page No: 4 of 5

All Vehicles (Cars & Trucks) Printed

Start Time	Blaine Avenue Southbound						Upper 55th Street Westbound						Blaine Avenue Northbound						Upper 55th Street Eastbound						Int. Veh. Total	Int. Ped/Bike Total
	U-Turn	Left	Thru	Right	App. Total	Peds/Bikes	U-Turn	Left	Thru	Right	App. Total	Peds/Bikes	U-Turn	Left	Thru	Right	App. Total	Peds/Bikes	U-Turn	Left	Thru	Right	App. Total	Peds/Bikes		
12:00	--	11	20	58	89	2	--	4	47	12	63	--	--	19	21	13	53	3	--	45	43	27	115	--	320	5
12:15	--	8	22	46	76	--	--	5	48	11	64	--	--	16	24	5	45	--	--	63	57	31	151	--	336	--
12:30	1	13	12	50	76	--	1	2	44	6	53	--	--	16	14	4	34	--	--	41	43	21	105	--	268	--
12:45	--	6	15	54	75	--	--	5	51	7	63	--	--	24	18	6	48	--	--	47	52	40	139	--	325	--
Hour Total	1	38	69	208	316	2	1	16	190	36	243	--	--	75	77	28	180	3	--	196	195	119	510	--	1249	5
% of App.	0.3%	12.0%	21.8%	65.8%			0.4%	6.6%	78.2%	14.8%			0.0%	41.7%	42.8%	15.6%			0.0%	38.4%	38.2%	23.3%				
% of Total	0.1%	3.0%	5.5%	16.7%	25.3%	40.0%	0.1%	1.3%	15.2%	2.9%	19.5%	0.0%	0.0%	6.0%	6.2%	2.2%	14.4%	60.0%	0.0%	15.7%	15.6%	9.5%	40.8%	0.0%		
Cars Total	1	38	69	208	316	2	1	16	189	36	242	--	--	75	77	27	179	1	--	195	192	117	504	--	1241	3
Cars % of Movement	100%	100%	100%	100%	100%	66.7%	100%	100%	99.5%	100%	99.6%	0.0%	0.0%	100%	100%	96.4%	99.4%	33.3%	0.0%	99.5%	98.5%	98.3%	98.8%	0.0%	99.4%	
Trucks Total	--	--	--	--	0	--	--	--	1	--	1	--	--	--	--	1	1	2	--	1	3	2	6	--	8	2
Trucks % of Movement	0.0%	0.0%	0.0%	0.0%	0.0%	0.0%	0.0%	0.0%	0.5%	0.0%	0.4%	0.0%	0.0%	0.0%	0.0%	3.6%	0.6%	100.0%	0.0%	0.5%	1.5%	1.7%	1.2%	0.0%	0.6%	

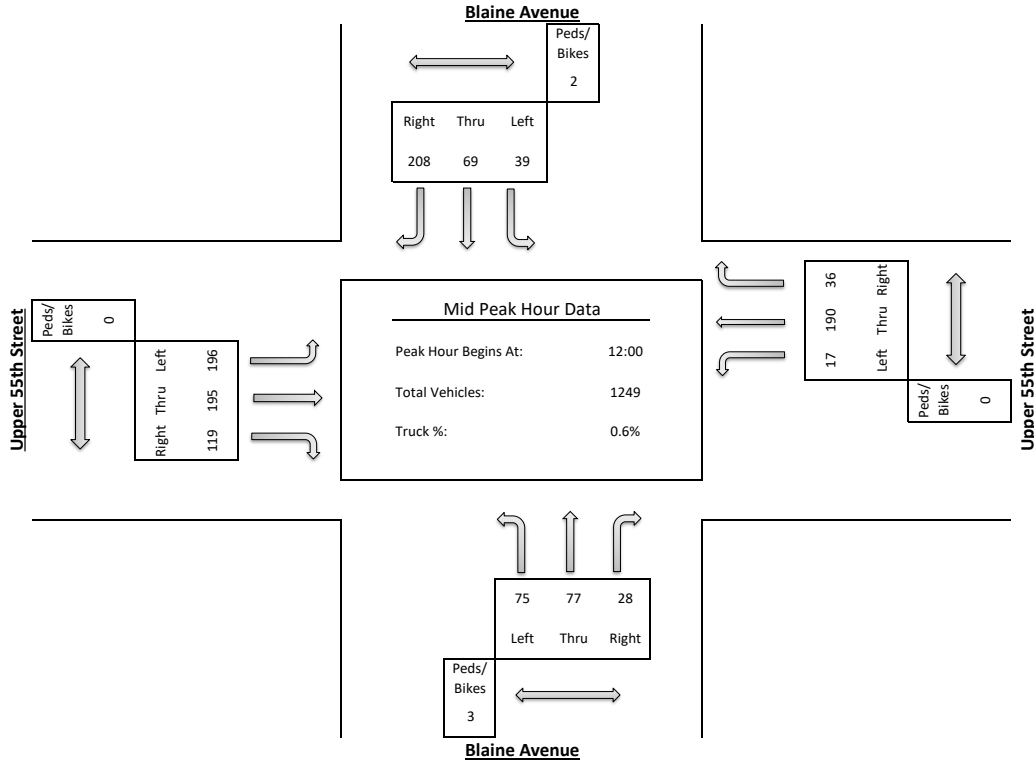

ALLIANT ENGINEERING, INC.

733 S Marquette Ave #700, Minneapolis, MN 55402

Intersection: Upper 55th Street & Blaine Avenue
 Date: 9/21/2024
 Duration: 0500-2300

Site Code: 422
 Ref Pt: N/A
 Page No: 5 of 5

All Vehicles (Cars & Trucks) Printed

Start Time	Blaine Avenue Southbound						Upper 55th Street Westbound						Blaine Avenue Northbound						Upper 55th Street Eastbound						Int. Veh. Total	Int. Ped/Bike Total
	U-Turn	Left	Thru	Right	App. Total	Peds/Bikes	U-Turn	Left	Thru	Right	App. Total	Peds/Bikes	U-Turn	Left	Thru	Right	App. Total	Peds/Bikes	U-Turn	Left	Thru	Right	App. Total	Peds/Bikes		
14:30	--	13	24	38	75	1	--	2	43	19	64	--	--	14	20	4	38	--	--	43	67	19	129	--	306	1
14:45	--	8	26	52	86	3	--	8	60	14	82	--	--	23	20	5	48	--	--	49	55	28	132	--	348	3
15:00	--	6	19	43	68	1	--	4	48	9	61	--	--	13	15	5	33	--	3	36	51	29	119	--	281	1
15:15	--	7	14	53	74	--	--	5	53	12	70	--	--	13	14	10	37	--	--	37	56	16	109	--	290	--
Hour Total	--	34	83	186	303	5	--	19	204	54	277	--	--	63	69	24	156	--	3	165	229	92	489	--	1225	5
% of App.	0.0%	11.2%	27.4%	61.4%			0.0%	6.9%	73.6%	19.5%			0.0%	40.4%	44.2%	15.4%			0.6%	33.7%	46.8%	18.8%				
% of Total	0.0%	2.8%	6.8%	15.2%	24.7%	100.0%	0.0%	1.6%	16.7%	4.4%	22.6%	0.0%	0.0%	5.1%	5.6%	2.0%	12.7%	0.0%	0.2%	13.5%	18.7%	7.5%	39.9%	0.0%		
Cars Total	--	34	83	186	303	2	--	19	203	54	276	--	--	63	69	24	156	--	3	165	228	92	488	--	1223	2
Cars % of Movement	0.0%	100%	100%	100%	100%	100.0%	0.0%	100%	99.5%	100%	99.6%	0.0%	0.0%	100%	100%	100%	100%	0.0%	100%	100%	99.6%	100%	99.8%	0.0%	99.8%	
Trucks Total	--	--	--	--	0	3	--	--	1	--	1	--	--	--	--	--	0	--	--	--	1	--	1	--	2	3
Trucks % of Movement	0.0%	0.0%	0.0%	0.0%	0.0%	100.0%	0.0%	0.0%	0.5%	0.0%	0.4%	0.0%	0.0%	0.0%	0.0%	0.0%	0.0%	0.0%	0.0%	0.0%	0.4%	0.0%	0.2%	0.0%	0.2%	

