

ALLIANT ENGINEERING, INC.

733 S Marquette Ave #700, Minneapolis, MN 55402

Intersection: 80th Street & TH 52 West Ramp - Barnes Avenue
 Date: 9/19/2024
 Duration: 0600-1900

Site Code: 410
 Ref Pt: N/A
 Page No: 2 of 4

All Vehicles (Cars & Trucks) Printed

Start Time	TH 52 West Ramp Southbound						80th Street Westbound						Barnes Avenue Northbound						80th Street Eastbound						Int. Veh. Total	Int. Ped/Bike Total
	U-Turn	Left	Thru	Right	App. Total	Peds/Bikes	U-Turn	Left	Thru	Right	App. Total	Peds/Bikes	U-Turn	Left	Thru	Right	App. Total	Peds/Bikes	U-Turn	Left	Thru	Right	App. Total	Peds/Bikes		
7:30	--	1	--	48	49	--	--	4	63	2	69	--	--	67	23	13	103	--	--	31	29	9	69	--	290	--
7:45	--	5	--	58	63	--	--	1	45	1	47	--	1	108	28	27	164	--	--	30	24	4	58	--	332	--
8:00	--	2	--	61	63	--	--	1	57	4	62	--	--	79	12	11	102	--	--	23	20	7	50	--	277	--
8:15	--	1	--	41	42	--	--	1	34	7	42	--	--	70	24	11	105	1	--	35	36	3	74	--	263	1
Hour Total	--	9	--	208	217	--	--	7	199	14	220	--	1	324	87	62	474	1	--	119	109	23	251	--	1162	1
% of App.	0.0%	4.1%	0.0%	95.9%			0.0%	3.2%	90.5%	6.4%			0.2%	68.4%	18.4%	13.1%			0.0%	47.4%	43.4%	9.2%				
% of Total	0.0%	0.8%	0.0%	17.9%	18.7%	0.0%	0.0%	0.6%	17.1%	1.2%	18.9%	0.0%	0.1%	27.9%	7.5%	5.3%	40.8%	100.0%	0.0%	10.2%	9.4%	2.0%	21.6%	0.0%		
Cars Total	--	9	--	204	213	--	--	7	193	14	214	--	1	320	79	62	462	1	--	118	107	23	248	--	1137	1
Cars % of Movement	0.0%	100%	0.0%	98.1%	98.2%	0.0%	0.0%	100%	97.0%	100%	97.3%	0.0%	100%	98.8%	90.8%	100%	97.5%	100.0%	0.0%	99.2%	98.2%	100%	98.8%	0.0%	97.8%	
Trucks Total	--	--	--	4	4	--	--	--	6	--	6	--	--	4	8	--	12	--	--	1	2	--	3	--	25	--
Trucks % of Movement	0.0%	0.0%	0.0%	1.9%	1.8%	--	0.0%	0.0%	3.0%	0.0%	2.7%	--	0.0%	1.2%	9.2%	0.0%	2.5%	--	0.0%	0.8%	1.8%	0.0%	1.2%	--	2.2%	

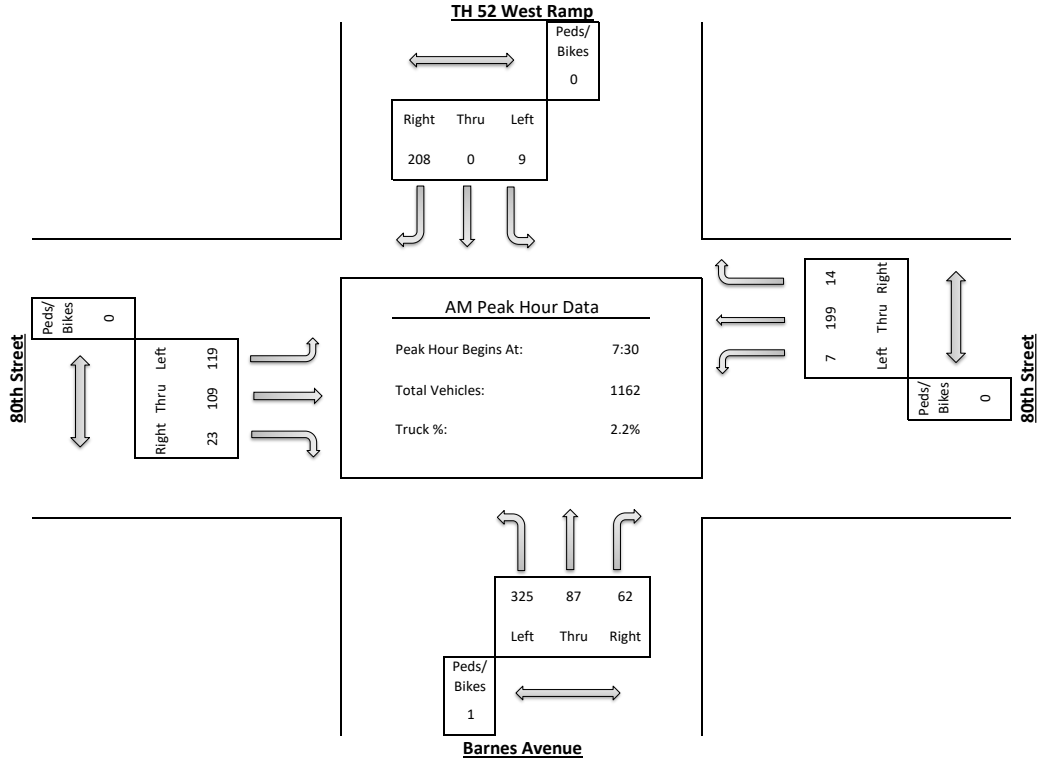

ALLIANT ENGINEERING, INC.

733 S Marquette Ave #700, Minneapolis, MN 55402

Intersection: 80th Street & TH 52 West Ramp - Barnes Avenue
 Date: 9/19/2024
 Duration: 0600-1900

Site Code: 410
 Ref Pt: N/A
 Page No: 3 of 4

All Vehicles (Cars & Trucks) Printed

Start Time	TH 52 West Ramp Southbound						80th Street Westbound						Barnes Avenue Northbound						80th Street Eastbound						Int. Veh. Total	Int. Ped/Bike Total
	U-Turn	Left	Thru	Right	App. Total	Peds/Bikes	U-Turn	Left	Thru	Right	App. Total	Peds/Bikes	U-Turn	Left	Thru	Right	App. Total	Peds/Bikes	U-Turn	Left	Thru	Right	App. Total	Peds/Bikes		
10:45	--	3	--	36	39	--	--	2	37	5	44	--	--	50	14	10	74	2	--	24	26	7	57	--	214	2
11:00	--	--	1	28	29	2	--	--	55	7	62	--	--	45	6	7	58	--	--	20	29	9	58	--	207	2
11:15	--	3	--	25	28	--	--	2	45	3	50	--	--	40	16	7	63	--	--	20	36	10	66	--	207	--
11:30	--	3	--	29	32	--	--	1	42	7	50	--	--	42	18	9	69	--	--	22	28	5	55	--	206	--
Hour Total	--	9	1	118	128	2	--	5	179	22	206	--	--	177	54	33	264	2	--	86	119	31	236	--	834	4
% of App.	0.0%	7.0%	0.8%	92.2%			0.0%	2.4%	86.9%	10.7%			0.0%	67.0%	20.5%	12.5%			0.0%	36.4%	50.4%	13.1%				
% of Total	0.0%	1.1%	0.1%	14.1%	15.3%	50.0%	0.0%	0.6%	21.5%	2.6%	24.7%	0.0%	0.0%	21.2%	6.5%	4.0%	31.7%	50.0%	0.0%	10.3%	14.3%	3.7%	28.3%	0.0%		
Cars Total	--	9	1	110	120	--	--	3	174	22	199	--	--	169	47	28	244	1	--	83	115	31	229	--	792	1
Cars % of Movement	0.0%	100%	100%	93.2%	93.8%	0.0%	0.0%	60.0%	97.2%	100%	96.6%	0.0%	0.0%	95.5%	87.0%	84.8%	92.4%	100.0%	0.0%	96.5%	96.6%	100%	97.0%	0.0%	95.0%	
Trucks Total	--	--	--	8	8	2	--	2	5	--	7	--	--	8	7	5	20	1	--	3	4	--	7	--	42	3
Trucks % of Movement	0.0%	0.0%	0.0%	6.8%	6.3%	66.7%	0.0%	40.0%	2.8%	0.0%	3.4%	0.0%	0.0%	4.5%	13.0%	15.2%	7.6%	33.3%	0.0%	3.5%	3.4%	0.0%	3.0%	0.0%	5.0%	

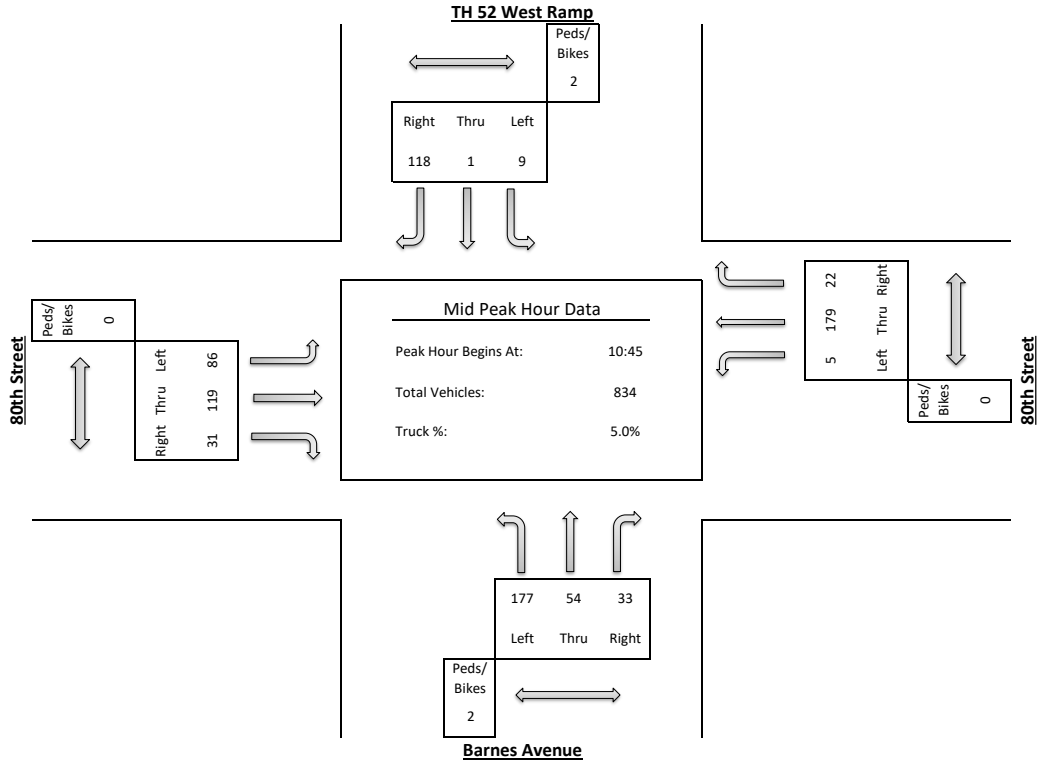

ALLIANT ENGINEERING, INC.

733 S Marquette Ave #700, Minneapolis, MN 55402

Intersection: 80th Street & TH 52 West Ramp - Barnes Avenue
 Date: 9/19/2024
 Duration: 0600-1900

Site Code: 410
 Ref Pt: N/A
 Page No: 4 of 4

All Vehicles (Cars & Trucks) Printed

Start Time	TH 52 West Ramp Southbound						80th Street Westbound						Barnes Avenue Northbound						80th Street Eastbound						Int. Veh. Total	Int. Ped/Bike Total
	U-Turn	Left	Thru	Right	App. Total	Peds/Bikes	U-Turn	Left	Thru	Right	App. Total	Peds/Bikes	U-Turn	Left	Thru	Right	App. Total	Peds/Bikes	U-Turn	Left	Thru	Right	App. Total	Peds/Bikes		
16:00	--	1	--	51	52	--	--	1	64	4	69	--	--	82	34	20	136	--	--	40	37	6	83	--	340	--
16:15	--	1	1	54	56	2	--	3	57	9	69	1	--	77	41	13	131	1	--	30	37	7	74	--	330	4
16:30	--	9	--	63	72	--	--	7	64	9	80	--	--	89	45	28	162	--	--	31	40	10	81	--	395	--
16:45	--	5	--	53	58	--	--	1	65	4	70	--	--	73	38	24	135	--	--	32	31	13	76	--	339	--
Hour Total	--	16	1	221	238	2	--	12	250	26	288	1	--	321	158	85	564	1	--	133	145	36	314	--	1404	4
% of App.	0.0%	6.7%	0.4%	92.9%			0.0%	4.2%	86.8%	9.0%			0.0%	56.9%	28.0%	15.1%			0.0%	42.4%	46.2%	11.5%				
% of Total	0.0%	1.1%	0.1%	15.7%	17.0%	50.0%	0.0%	0.9%	17.8%	1.9%	20.5%	25.0%	0.0%	22.9%	11.3%	6.1%	40.2%	25.0%	0.0%	9.5%	10.3%	2.6%	22.4%	0.0%		
Cars Total	--	16	1	216	233	--	--	12	247	24	283	--	--	320	149	81	550	1	--	131	145	34	310	--	1376	1
Cars % of Movement	0.0%	100%	100%	97.7%	97.9%	0.0%	0.0%	100%	98.8%	92.3%	98.3%	0.0%	0.0%	99.7%	94.3%	95.3%	97.5%	100.0%	0.0%	98.5%	100%	94.4%	98.7%	0.0%	98.0%	
Trucks Total	--	--	--	5	5	2	--	--	3	2	5	1	--	1	9	4	14	--	--	2	--	2	4	--	28	3
Trucks % of Movement	0.0%	0.0%	0.0%	2.3%	2.1%	66.7%	0.0%	0.0%	1.2%	7.7%	1.7%	33.3%	0.0%	0.3%	5.7%	4.7%	2.5%	0.0%	0.0%	1.5%	0.0%	5.6%	1.3%	0.0%	2.0%	

