

Alliant Engineering, Inc.

733 Marquette Ave #700, Minneapolis, MN 55402

CSAH 101 & TH 212 N Ramp
 Ref Pt: 152+00.837
 data by: Alliant Inc
 TURN MOVEMENT COUNT

File Name : 1736522_CSAH 101 & TH 212 N Ramp
 Site Code : 1736522
 Start Date : 2/14/2019
 Page No : 1

Groups Printed- Cars - Trucks

Start Time	Powers Blvd Southbound					TH 212 S Ramp Westbound					Powers Blvd Northbound					TH 212 S Ramp Eastbound					Int. Total
	Right	Thru	Left	Peds	App. Total	Right	Thru	Left	Peds	App. Total	Right	Thru	Left	Peds	App. Total	Right	Thru	Left	Peds	App. Total	
06:00 AM	1	21	1	0	23	15	1	14	0	30	1	37	0	0	38	5	1	1	0	7	98
06:15 AM	0	29	2	0	31	17	1	27	0	45	2	31	0	0	33	3	0	1	0	4	113
06:30 AM	0	31	5	0	36	22	0	17	0	39	7	31	1	0	39	8	1	6	0	15	129
06:45 AM	3	45	6	0	54	24	6	32	0	62	5	61	3	0	69	11	3	2	0	16	201
Total	4	126	14	0	144	78	8	90	0	176	15	160	4	0	179	27	5	10	0	42	541
07:00 AM	2	38	6	0	46	25	2	27	0	54	6	83	2	0	91	14	1	9	0	24	215
07:15 AM	2	51	12	0	65	19	4	29	0	52	8	86	2	0	96	21	0	14	0	35	248
07:30 AM	5	53	16	0	74	35	0	36	0	71	11	173	3	0	187	7	1	8	0	16	348
07:45 AM	1	58	13	0	72	38	1	26	0	65	16	220	4	0	240	10	3	11	0	24	401
Total	10	200	47	0	257	117	7	118	0	242	41	562	11	0	614	52	5	42	0	99	1212
08:00 AM	2	67	14	0	83	40	3	43	0	86	9	225	3	0	237	14	3	9	0	26	432
08:15 AM	5	70	9	0	84	32	5	32	0	69	5	126	2	0	133	13	2	9	0	24	310
08:30 AM	4	66	12	0	82	28	3	29	0	60	9	99	3	0	111	13	2	6	0	21	274
08:45 AM	7	62	12	0	81	32	2	21	0	55	3	103	3	0	109	8	1	10	0	19	264
Total	18	265	47	0	330	132	13	125	0	270	26	553	11	0	590	48	8	34	0	90	1280
09:00 AM	2	58	14	0	74	42	1	26	0	69	5	122	2	0	129	4	0	5	0	9	281
09:15 AM	8	72	16	0	96	32	5	33	0	70	5	85	6	0	96	13	1	9	0	23	285
09:30 AM	8	63	6	0	77	21	4	24	0	49	8	82	6	0	96	7	1	10	0	18	240
09:45 AM	7	75	13	0	95	15	3	19	0	37	6	92	0	0	98	8	1	11	0	20	250
Total	25	268	49	0	342	110	13	102	0	225	24	381	14	0	419	32	3	35	0	70	1056
10:00 AM	4	52	16	0	72	26	5	19	0	50	7	64	5	0	76	6	1	2	0	9	207
10:15 AM	4	54	15	0	73	15	4	19	0	38	10	64	0	0	74	4	0	5	0	9	194
10:30 AM	7	43	6	0	56	20	3	31	0	54	2	107	3	0	112	6	0	3	0	9	231
10:45 AM	2	45	9	0	56	19	4	23	0	46	6	50	4	0	60	4	0	4	0	8	170
Total	17	194	46	0	257	80	16	92	0	188	25	285	12	0	322	20	1	14	0	35	802
11:00 AM	2	50	7	0	59	23	3	15	0	41	4	61	5	0	70	13	2	5	0	20	190
11:15 AM	8	61	17	0	86	19	3	25	0	47	6	60	1	0	67	6	0	7	0	13	213
11:30 AM	1	77	31	0	109	18	4	23	0	45	6	78	4	0	88	6	1	6	0	13	255
11:45 AM	3	75	22	0	100	18	4	30	0	52	3	57	3	0	63	8	0	1	0	9	224
Total	14	263	77	0	354	78	14	93	0	185	19	256	13	0	288	33	3	19	0	55	882
12:00 PM	2	66	20	0	88	11	5	27	0	43	8	83	1	0	92	9	0	4	0	13	236
12:15 PM	6	66	5	0	77	18	4	33	0	55	4	69	6	0	79	7	0	6	0	13	224
12:30 PM	5	75	11	0	91	25	3	38	0	66	6	64	4	0	74	10	1	3	0	14	245
12:45 PM	10	70	18	0	98	27	5	35	0	67	9	81	2	0	92	8	4	6	0	18	275
Total	23	277	54	0	354	81	17	133	0	231	27	297	13	0	337	34	5	19	0	58	980
01:00 PM	5	77	20	0	102	19	1	26	0	46	12	64	0	0	76	4	1	3	0	8	232
01:15 PM	3	75	20	0	98	31	0	28	0	59	7	49	2	0	58	5	0	3	0	8	223
01:30 PM	9	69	22	0	100	15	4	33	0	52	3	65	3	0	71	2	1	2	0	5	228
01:45 PM	6	74	24	0	104	23	5	32	0	60	10	49	0	0	59	7	1	0	0	8	231
Total	23	295	86	0	404	88	10	119	0	217	32	227	5	0	264	18	3	8	0	29	914
02:00 PM	5	69	27	0	101	24	7	21	0	52	11	53	3	0	67	2	0	5	0	7	227
02:15 PM	1	74	26	0	101	26	2	41	0	69	5	78	2	0	85	8	2	3	0	13	268
02:30 PM	4	95	18	0	117	21	3	24	0	48	6	73	0	0	79	5	0	4	0	9	253
02:45 PM	11	117	44	0	172	40	8	64	0	112	6	72	6	0	84	3	1	4	0	8	376
Total	21	355	115	0	491	111	20	150	0	281	28	276	11	0	315	18	3	16	0	37	1124
03:00 PM	5	102	23	0	130	51	3	51	0	105	10	89	2	0	101	10	0	5	0	15	351
03:15 PM	7	138	26	0	171	34	5	57	0	96	7	79	5	0	91	7	2	7	0	16	374
03:30 PM	11	106	35	0	152	37	9	70	0	116	10	94	1	0	105	4	3	7	0	14	387

Alliant Engineering, Inc.

733 Marquette Ave #700, Minneapolis, MN 55402

CSAH 101 & TH 212 N Ramp
 Ref Pt: 152+00.837
 data by: Alliant Inc
 TURN MOVEMENT COUNT

File Name : 1736522_CSAH 101 & TH 212 N Ramp
 Site Code : 1736522
 Start Date : 2/14/2019
 Page No : 2

Groups Printed- Cars - Trucks

Start Time	Powers Blvd Southbound					TH 212 S Ramp Westbound					Powers Blvd Northbound					TH 212 S Ramp Eastbound					Int. Total
	Right	Thru	Left	Peds	App. Total	Right	Thru	Left	Peds	App. Total	Right	Thru	Left	Peds	App. Total	Right	Thru	Left	Peds	App. Total	
03:45 PM	5	115	30	0	150	21	2	50	0	73	8	134	1	0	143	5	0	5	0	10	376
Total	28	461	114	0	603	143	19	228	0	390	35	396	9	0	440	26	5	24	0	55	1488
04:00 PM	7	112	34	0	153	40	4	71	0	115	8	125	4	0	137	6	0	3	0	9	414
04:15 PM	9	136	51	0	196	23	9	57	0	89	17	101	5	0	123	2	0	6	0	8	416
04:30 PM	12	131	42	0	185	31	10	73	0	114	16	111	5	0	132	7	0	3	0	10	441
04:45 PM	12	125	49	0	186	23	8	60	0	91	19	116	6	0	141	9	1	11	0	21	439
Total	40	504	176	0	720	117	31	261	0	409	60	453	20	0	533	24	1	23	0	48	1710
05:00 PM	10	125	55	0	190	27	5	65	0	97	18	136	5	0	159	5	1	8	0	14	460
05:15 PM	12	147	41	0	200	30	6	66	0	102	17	132	1	0	150	11	2	11	0	24	476
05:30 PM	12	127	58	0	197	30	3	52	0	85	12	119	2	0	133	5	1	5	0	11	426
05:45 PM	14	150	47	0	211	32	8	65	0	105	22	124	4	0	150	5	0	7	0	12	478
Total	48	549	201	0	798	119	22	248	0	389	69	511	12	0	592	26	4	31	0	61	1840
06:00 PM	17	121	40	0	178	35	12	70	0	117	14	107	0	0	121	6	0	6	0	12	428
06:15 PM	18	112	52	0	182	30	8	66	0	104	21	95	4	0	120	8	0	6	0	14	420
06:30 PM	13	111	20	0	144	31	8	68	0	107	17	95	5	0	117	6	2	9	0	17	385
06:45 PM	11	78	24	0	113	31	9	66	0	106	17	85	2	0	104	7	1	5	0	13	336
Total	59	422	136	0	617	127	37	270	0	434	69	382	11	0	462	27	3	26	0	56	1569
Grand Total	330	4179	1162	0	5671	1381	227	2029	0	3637	470	4739	146	0	5355	385	49	301	0	735	15398
Apprch %	5.8	73.7	20.5	0		38	6.2	55.8	0		8.8	88.5	2.7	0		52.4	6.7	41	0		
Total %	2.1	27.1	7.5	0	36.8	9	1.5	13.2	0	23.6	3.1	30.8	0.9	0	34.8	2.5	0.3	2	0	4.8	
Cars	318	4041	1131	0	5490	1346	217	1948	0	3511	425	4603	134	0	5162	365	40	294	0	699	14862
% Cars	96.4	96.7	97.3	0	96.8	97.5	95.6	96	0	96.5	90.4	97.1	91.8	0	96.4	94.8	81.6	97.7	0	95.1	96.5
Trucks	12	138	31	0	181	35	10	81	0	126	45	136	12	0	193	20	9	7	0	36	536
% Trucks	3.6	3.3	2.7	0	3.2	2.5	4.4	4	0	3.5	9.6	2.9	8.2	0	3.6	5.2	18.4	2.3	0	4.9	3.5

Alliant Engineering, Inc.

733 Marquette Ave #700, Minneapolis, MN 55402

CSAH 101 & TH 212 N Ramp
 Ref Pt: 152+00.837
 data by: Alliant Inc
 TURN MOVEMENT COUNT

File Name : 1736522_CSAH 101 & TH 212 N Ramp
 Site Code : 1736522
 Start Date : 2/14/2019
 Page No : 3

Start Time	Powers Blvd Southbound					TH 212 S Ramp Westbound					Powers Blvd Northbound					TH 212 S Ramp Eastbound					Int. Total
	Right	Thru	Left	Peds	App. Total	Right	Thru	Left	Peds	App. Total	Right	Thru	Left	Peds	App. Total	Right	Thru	Left	Peds	App. Total	
Peak Hour Analysis From 06:00 AM to 09:45 AM - Peak 1 of 1																					
Peak Hour for Entire Intersection Begins at 07:30 AM																					
07:30 AM	5	53	16	0	74	35	0	36	0	71	11	173	3	0	187	7	1	8	0	16	348
07:45 AM	1	58	13	0	72	38	1	26	0	65	16	220	4	0	240	10	3	11	0	24	401
08:00 AM	2	67	14	0	83	40	3	43	0	86	9	225	3	0	237	14	3	9	0	26	432
08:15 AM	5	70	9	0	84	32	5	32	0	69	5	126	2	0	133	13	2	9	0	24	310
Total Volume	13	248	52	0	313	145	9	137	0	291	41	744	12	0	797	44	9	37	0	90	1491
% App. Total	4.2	79.2	16.6	0		49.8	3.1	47.1	0		5.1	93.4	1.5	0		48.9	10	41.1	0		
PHF	.650	.886	.813	.000	.932	.906	.450	.797	.000	.846	.641	.827	.750	.000	.830	.786	.750	.841	.000	.865	.863

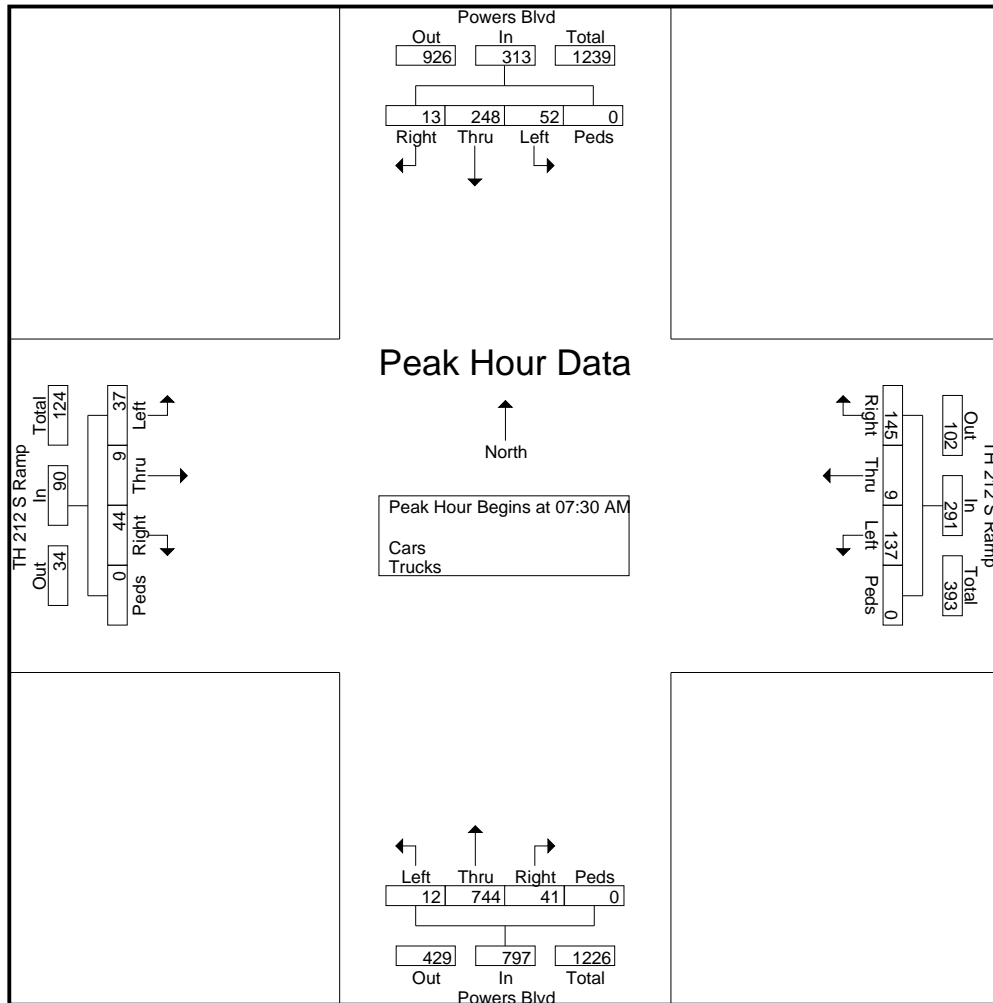

Alliant Engineering, Inc.

733 Marquette Ave #700, Minneapolis, MN 55402

CSAH 101 & TH 212 N Ramp
 Ref Pt: 152+00.837
 data by: Alliant Inc
 TURN MOVEMENT COUNT

File Name : 1736522_CSAH 101 & TH 212 N Ramp
 Site Code : 1736522
 Start Date : 2/14/2019
 Page No : 4

Start Time	Powers Blvd Southbound					TH 212 S Ramp Westbound					Powers Blvd Northbound					TH 212 S Ramp Eastbound					Int. Total
	Right	Thru	Left	Peds	App. Total	Right	Thru	Left	Peds	App. Total	Right	Thru	Left	Peds	App. Total	Right	Thru	Left	Peds	App. Total	
Peak Hour Analysis From 10:00 AM to 01:45 PM - Peak 1 of 1																					
Peak Hour for Entire Intersection Begins at 12:00 PM																					
12:00 PM	2	66	20	0	88	11	5	27	0	43	8	83	1	0	92	9	0	4	0	13	236
12:15 PM	6	66	5	0	77	18	4	33	0	55	4	69	6	0	79	7	0	6	0	13	224
12:30 PM	5	75	11	0	91	25	3	38	0	66	6	64	4	0	74	10	1	3	0	14	245
12:45 PM	10	70	18	0	98	27	5	35	0	67	9	81	2	0	92	8	4	6	0	18	275
Total Volume	23	277	54	0	354	81	17	133	0	231	27	297	13	0	337	34	5	19	0	58	980
% App. Total	6.5	78.2	15.3	0		35.1	7.4	57.6	0		8	88.1	3.9	0		58.6	8.6	32.8	0		
PHF	.575	.923	.675	.000	.903	.750	.850	.875	.000	.862	.750	.895	.542	.000	.916	.850	.313	.792	.000	.806	.891

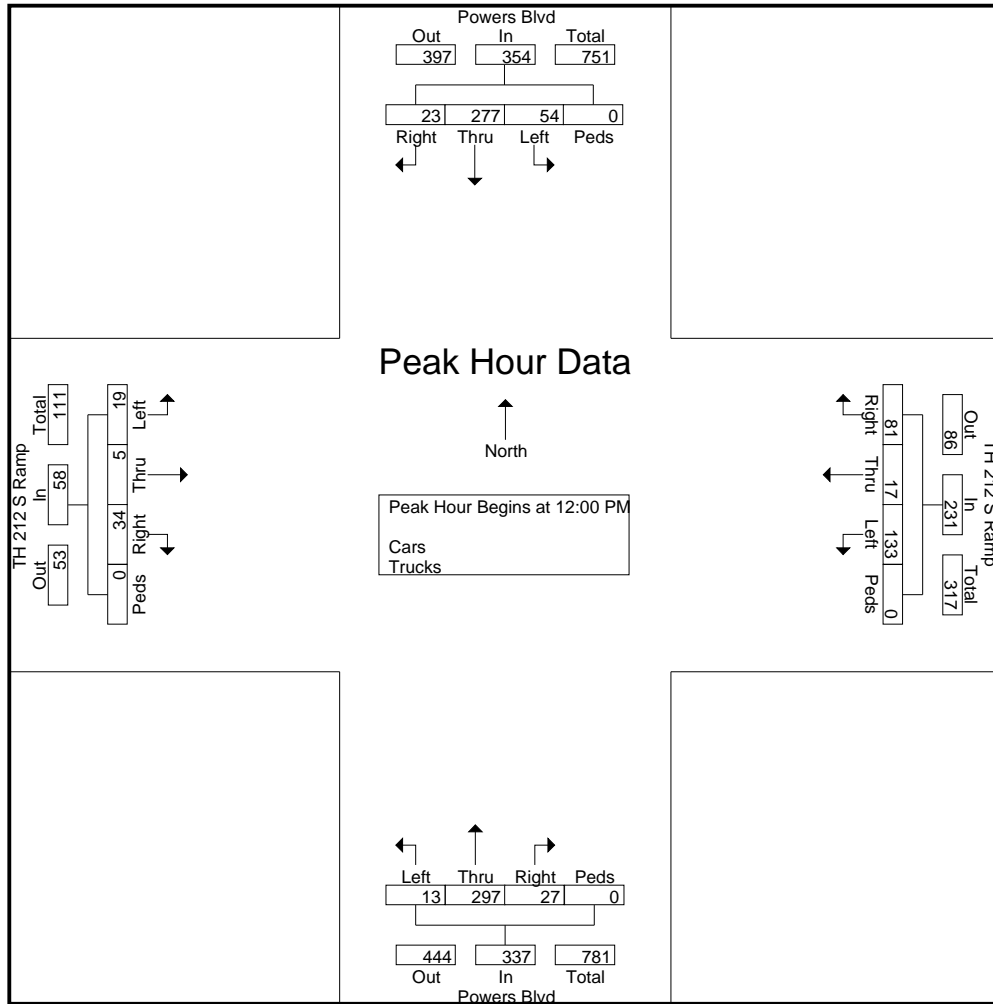

Alliant Engineering, Inc.

733 Marquette Ave #700, Minneapolis, MN 55402

CSAH 101 & TH 212 N Ramp
 Ref Pt: 152+00.837
 data by: Alliant Inc
 TURN MOVEMENT COUNT

File Name : 1736522_CSAH 101 & TH 212 N Ramp
 Site Code : 1736522
 Start Date : 2/14/2019
 Page No : 5

Start Time	Powers Blvd Southbound					TH 212 S Ramp Westbound					Powers Blvd Northbound					TH 212 S Ramp Eastbound					Int. Total
	Right	Thru	Left	Peds	App. Total	Right	Thru	Left	Peds	App. Total	Right	Thru	Left	Peds	App. Total	Right	Thru	Left	Peds	App. Total	
Peak Hour Analysis From 02:00 PM to 05:45 PM - Peak 1 of 1																					
Peak Hour for Entire Intersection Begins at 05:00 PM																					
05:00 PM	10	125	55	0	190	27	5	65	0	97	18	136	5	0	159	5	1	8	0	14	460
05:15 PM	12	147	41	0	200	30	6	66	0	102	17	132	1	0	150	11	2	11	0	24	476
05:30 PM	12	127	58	0	197	30	3	52	0	85	12	119	2	0	133	5	1	5	0	11	426
05:45 PM	14	150	47	0	211	32	8	65	0	105	22	124	4	0	150	5	0	7	0	12	478
Total Volume	48	549	201	0	798	119	22	248	0	389	69	511	12	0	592	26	4	31	0	61	1840
% App. Total	6	68.8	25.2	0		30.6	5.7	63.8	0		11.7	86.3	2	0		42.6	6.6	50.8	0		
PHF	.857	.915	.866	.000	.945	.930	.688	.939	.000	.926	.784	.939	.600	.000	.931	.591	.500	.705	.000	.635	.962

