

Alliant Engineering, Inc

233 Park Ave Suite 300

Minneapolis, MN 55415

--TRAFFIC DATA --

CSAH-17 at 17th Avenue
 Ref.Pt.: Not Available
 data by : Alliant Inc.
 TURN MOVEMENT COUNT

File Name : 331_CSAH 17 & 17th Ave
 Site Code : 331
 Start Date : 11/8/2017
 Page No : 1

Groups Printed- Vehicles - Trucks

| Start Time | CSAH 17 From North | | | | 17th Ave From East | | | | CSAH 17 From South | | | | 17th Ave From West | | | | Int. Total |
|---------------|-----------------------|------|------|------|-----------------------|------|------|------|-----------------------|------|------|------|-----------------------|------|------|------|------------|
| | Other | Left | Thru | Rght | Other | Left | Thru | Rght | Other | Left | Thru | Rght | Other | Left | Thru | Rght | |
| 06:00 AM | 1 | 19 | 9 | 34 | 0 | 0 | 15 | 36 | 0 | 3 | 52 | 2 | 0 | 55 | 8 | 0 | 234 |
| 06:15 AM | 0 | 39 | 21 | 37 | 0 | 0 | 15 | 44 | 0 | 10 | 55 | 3 | 0 | 68 | 13 | 0 | 305 |
| 06:30 AM | 0 | 46 | 31 | 43 | 0 | 0 | 18 | 63 | 0 | 11 | 83 | 4 | 0 | 87 | 19 | 1 | 406 |
| 06:45 AM | 0 | 58 | 33 | 45 | 0 | 1 | 24 | 81 | 1 | 14 | 139 | 3 | 0 | 103 | 19 | 0 | 521 |
| Total | 1 | 162 | 94 | 159 | 0 | 1 | 72 | 224 | 1 | 38 | 329 | 12 | 0 | 313 | 59 | 1 | 1466 |
| 07:00 AM | 0 | 60 | 43 | 34 | 0 | 0 | 58 | 126 | 0 | 13 | 140 | 0 | 0 | 101 | 16 | 0 | 591 |
| 07:15 AM | 0 | 61 | 59 | 76 | 0 | 12 | 79 | 109 | 0 | 19 | 127 | 11 | 0 | 97 | 56 | 0 | 706 |
| 07:30 AM | 0 | 76 | 50 | 66 | 0 | 3 | 60 | 83 | 0 | 28 | 134 | 5 | 0 | 118 | 33 | 1 | 657 |
| 07:45 AM | 0 | 80 | 59 | 58 | 0 | 3 | 88 | 86 | 0 | 24 | 142 | 12 | 0 | 111 | 28 | 1 | 692 |
| Total | 0 | 277 | 211 | 234 | 0 | 18 | 285 | 404 | 0 | 84 | 543 | 28 | 0 | 427 | 133 | 2 | 2646 |
| 08:00 AM | 0 | 56 | 31 | 63 | 0 | 0 | 76 | 65 | 0 | 19 | 102 | 3 | 0 | 96 | 38 | 1 | 550 |
| 08:15 AM | 0 | 54 | 37 | 42 | 0 | 1 | 51 | 102 | 0 | 13 | 71 | 2 | 0 | 93 | 32 | 3 | 501 |
| 08:30 AM | 0 | 54 | 38 | 31 | 0 | 0 | 32 | 76 | 0 | 13 | 65 | 0 | 0 | 75 | 69 | 6 | 459 |
| 08:45 AM | 0 | 70 | 44 | 41 | 0 | 1 | 48 | 75 | 0 | 12 | 79 | 5 | 0 | 67 | 44 | 1 | 487 |
| Total | 0 | 234 | 150 | 177 | 0 | 2 | 207 | 318 | 0 | 57 | 317 | 10 | 0 | 331 | 183 | 11 | 1997 |
| 09:00 AM | 0 | 65 | 65 | 27 | 0 | 4 | 39 | 74 | 0 | 16 | 70 | 4 | 0 | 52 | 35 | 1 | 452 |
| 09:15 AM | 0 | 51 | 51 | 33 | 0 | 3 | 23 | 56 | 0 | 7 | 83 | 4 | 0 | 63 | 23 | 2 | 399 |
| *** BREAK *** | | | | | | | | | | | | | | | | | |
| Total | 0 | 116 | 116 | 60 | 0 | 7 | 62 | 130 | 0 | 23 | 153 | 8 | 0 | 115 | 58 | 3 | 851 |
| *** BREAK *** | | | | | | | | | | | | | | | | | |
| 10:30 AM | 0 | 55 | 52 | 37 | 1 | 2 | 45 | 63 | 0 | 15 | 63 | 3 | 0 | 40 | 10 | 3 | 389 |
| 10:45 AM | 0 | 58 | 55 | 26 | 0 | 2 | 24 | 84 | 0 | 15 | 55 | 8 | 0 | 47 | 29 | 4 | 407 |
| Total | 0 | 113 | 107 | 63 | 1 | 4 | 69 | 147 | 0 | 30 | 118 | 11 | 0 | 87 | 39 | 7 | 796 |
| 11:00 AM | 0 | 57 | 51 | 40 | 0 | 2 | 48 | 71 | 0 | 4 | 45 | 2 | 0 | 53 | 21 | 1 | 395 |
| 11:15 AM | 0 | 80 | 51 | 37 | 0 | 3 | 45 | 75 | 0 | 8 | 65 | 0 | 0 | 38 | 22 | 1 | 425 |
| 11:30 AM | 0 | 89 | 57 | 42 | 0 | 13 | 35 | 88 | 0 | 10 | 66 | 0 | 0 | 47 | 29 | 2 | 478 |
| 11:45 AM | 0 | 72 | 58 | 45 | 0 | 7 | 24 | 89 | 0 | 3 | 86 | 0 | 0 | 49 | 31 | 0 | 464 |
| Total | 0 | 298 | 217 | 164 | 0 | 25 | 152 | 323 | 0 | 25 | 262 | 2 | 0 | 187 | 103 | 4 | 1762 |
| 12:00 PM | 0 | 79 | 54 | 42 | 0 | 8 | 25 | 76 | 0 | 8 | 73 | 0 | 0 | 56 | 24 | 0 | 445 |
| 12:15 PM | 0 | 78 | 60 | 57 | 0 | 3 | 49 | 88 | 0 | 7 | 58 | 6 | 0 | 27 | 29 | 3 | 465 |
| 12:30 PM | 0 | 87 | 62 | 49 | 0 | 2 | 43 | 77 | 0 | 9 | 74 | 2 | 0 | 54 | 34 | 4 | 497 |
| 12:45 PM | 0 | 84 | 72 | 53 | 0 | 5 | 40 | 62 | 0 | 4 | 59 | 2 | 0 | 47 | 25 | 7 | 460 |
| Total | 0 | 328 | 248 | 201 | 0 | 18 | 157 | 303 | 0 | 28 | 264 | 10 | 0 | 184 | 112 | 14 | 1867 |
| 01:00 PM | 0 | 74 | 76 | 32 | 0 | 0 | 15 | 65 | 0 | 12 | 55 | 1 | 0 | 36 | 20 | 5 | 391 |
| 01:15 PM | 0 | 76 | 67 | 37 | 0 | 12 | 51 | 83 | 0 | 11 | 58 | 0 | 0 | 42 | 37 | 4 | 478 |
| *** BREAK *** | | | | | | | | | | | | | | | | | |
| Total | 0 | 150 | 143 | 69 | 0 | 12 | 66 | 148 | 0 | 23 | 113 | 1 | 0 | 78 | 57 | 9 | 869 |
| *** BREAK *** | | | | | | | | | | | | | | | | | |
| 02:30 PM | 0 | 97 | 85 | 73 | 0 | 3 | 36 | 93 | 0 | 4 | 43 | 0 | 0 | 21 | 10 | 1 | 466 |
| 02:45 PM | 0 | 140 | 81 | 87 | 0 | 9 | 52 | 85 | 0 | 10 | 59 | 0 | 0 | 61 | 29 | 2 | 615 |
| Total | 0 | 237 | 166 | 160 | 0 | 12 | 88 | 178 | 0 | 14 | 102 | 0 | 0 | 82 | 39 | 3 | 1081 |
| 03:00 PM | 0 | 86 | 93 | 85 | 0 | 4 | 58 | 92 | 0 | 7 | 65 | 0 | 0 | 67 | 77 | 1 | 635 |
| 03:15 PM | 0 | 128 | 93 | 74 | 0 | 7 | 70 | 104 | 0 | 15 | 82 | 0 | 0 | 96 | 86 | 8 | 763 |
| 03:30 PM | 0 | 112 | 108 | 58 | 0 | 17 | 75 | 134 | 0 | 12 | 103 | 0 | 0 | 74 | 67 | 3 | 763 |
| 03:45 PM | 0 | 117 | 107 | 105 | 0 | 12 | 77 | 100 | 0 | 18 | 75 | 1 | 0 | 68 | 52 | 3 | 735 |
| Total | 0 | 443 | 401 | 322 | 0 | 40 | 280 | 430 | 0 | 52 | 325 | 1 | 0 | 305 | 282 | 15 | 2896 |
| 04:00 PM | 0 | 99 | 123 | 90 | 0 | 21 | 63 | 105 | 0 | 14 | 70 | 0 | 0 | 85 | 41 | 6 | 717 |
| 04:15 PM | 0 | 140 | 104 | 91 | 0 | 15 | 87 | 96 | 0 | 8 | 99 | 1 | 0 | 66 | 47 | 5 | 759 |
| 04:30 PM | 0 | 120 | 133 | 83 | 0 | 13 | 90 | 96 | 0 | 7 | 64 | 0 | 0 | 69 | 61 | 6 | 742 |
| 04:45 PM | 1 | 121 | 148 | 92 | 0 | 16 | 62 | 130 | 0 | 12 | 105 | 2 | 0 | 66 | 61 | 3 | 819 |
| Total | 1 | 480 | 508 | 356 | 0 | 65 | 302 | 427 | 0 | 41 | 338 | 3 | 0 | 286 | 210 | 20 | 3037 |

Alliant Engineering, Inc

233 Park Ave Suite 300

Minneapolis, MN 55415

--TRAFFIC DATA --

CSAH-17 at 17th Avenue
 Ref.Pt.: Not Available
 data by : Alliant Inc.
 TURN MOVEMENT COUNT

File Name : 331_CSAH 17 & 17th Ave
 Site Code : 331
 Start Date : 11/8/2017
 Page No : 2

Groups Printed- Vehicles - Trucks

| Start Time | CSAH 17 From North | | | | 17th Ave From East | | | | CSAH 17 From South | | | | 17th Ave From West | | | | Int. Total |
|-------------|-----------------------|------|------|------|-----------------------|------|------|------|-----------------------|------|------|------|-----------------------|------|------|------|------------|
| | Other | Left | Thru | Rght | Other | Left | Thru | Rght | Other | Left | Thru | Rght | Other | Left | Thru | Rght | |
| 05:00 PM | 0 | 129 | 145 | 105 | 0 | 12 | 80 | 101 | 0 | 4 | 74 | 0 | 0 | 74 | 55 | 4 | 783 |
| 05:15 PM | 0 | 117 | 147 | 95 | 0 | 5 | 74 | 80 | 0 | 13 | 56 | 3 | 0 | 48 | 62 | 11 | 711 |
| 05:30 PM | 0 | 102 | 125 | 117 | 0 | 7 | 50 | 96 | 0 | 9 | 106 | 2 | 0 | 56 | 49 | 2 | 721 |
| 05:45 PM | 0 | 94 | 125 | 90 | 0 | 12 | 72 | 69 | 0 | 14 | 115 | 1 | 0 | 77 | 75 | 11 | 755 |
| Total | 0 | 442 | 542 | 407 | 0 | 36 | 276 | 346 | 0 | 40 | 351 | 6 | 0 | 255 | 241 | 28 | 2970 |
| Grand Total | 2 | 3280 | 2903 | 2372 | 1 | 240 | 2016 | 3378 | 1 | 455 | 3215 | 92 | 0 | 2650 | 1516 | 117 | 22238 |
| Apprch % | 0 | 38.3 | 33.9 | 27.7 | 0 | 4.3 | 35.8 | 59.9 | 0 | 12.1 | 85.4 | 2.4 | 0 | 61.9 | 35.4 | 2.7 | |
| Total % | 0 | 14.7 | 13.1 | 10.7 | 0 | 1.1 | 9.1 | 15.2 | 0 | 2 | 14.5 | 0.4 | 0 | 11.9 | 6.8 | 0.5 | |
| Vehicles | 1 | 3193 | 2793 | 2269 | 1 | 238 | 1972 | 3290 | 1 | 426 | 3125 | 89 | 0 | 2549 | 1478 | 111 | 21536 |
| % Vehicles | 50 | 97.3 | 96.2 | 95.7 | 100 | 99.2 | 97.8 | 97.4 | 100 | 93.6 | 97.2 | 96.7 | 0 | 96.2 | 97.5 | 94.9 | 96.8 |
| Trucks | 1 | 87 | 110 | 103 | 0 | 2 | 44 | 88 | 0 | 29 | 90 | 3 | 0 | 101 | 38 | 6 | 702 |
| % Trucks | 50 | 2.7 | 3.8 | 4.3 | 0 | 0.8 | 2.2 | 2.6 | 0 | 6.4 | 2.8 | 3.3 | 0 | 3.8 | 2.5 | 5.1 | 3.2 |

Alliant Engineering, Inc

233 Park Ave Suite 300
 Minneapolis, MN 55415
 --TRAFFIC DATA --

CSAH-17 at 17th Avenue
 Ref.Pt.: Not Available
 data by : Alliant Inc.
 TURN MOVEMENT COUNT

File Name : 331_CSAH 17 & 17th Ave
 Site Code : 331
 Start Date : 11/8/2017
 Page No : 3

| Start Time | CSAH 17 From North | | | | | 17th Ave From East | | | | | CSAH 17 From South | | | | | 17th Ave From West | | | | | Int. Total |
|--|--------------------|------|------|------|------------|--------------------|------|------|------|------------|--------------------|------|------|------|------------|--------------------|------|------|------|------------|------------|
| | Other | Left | Thru | Rght | App. Total | Other | Left | Thru | Rght | App. Total | Other | Left | Thru | Rght | App. Total | Other | Left | Thru | Rght | App. Total | |
| Peak Hour Analysis From 06:00 AM to 11:45 AM - Peak 1 of 1 | | | | | | | | | | | | | | | | | | | | | |
| Peak Hour for Entire Intersection Begins at 07:00 AM | | | | | | | | | | | | | | | | | | | | | |
| 07:00 AM | 0 | 60 | 43 | 34 | 137 | 0 | 0 | 58 | 126 | 184 | 0 | 13 | 140 | 0 | 153 | 0 | 101 | 16 | 0 | 117 | 591 |
| 07:15 AM | 0 | 61 | 59 | 76 | 196 | 0 | 12 | 79 | 109 | 200 | 0 | 19 | 127 | 11 | 157 | 0 | 97 | 56 | 0 | 153 | 706 |
| 07:30 AM | 0 | 76 | 50 | 66 | 192 | 0 | 3 | 60 | 83 | 146 | 0 | 28 | 134 | 5 | 167 | 0 | 118 | 33 | 1 | 152 | 657 |
| 07:45 AM | 0 | 80 | 59 | 58 | 197 | 0 | 3 | 88 | 86 | 177 | 0 | 24 | 142 | 12 | 178 | 0 | 111 | 28 | 1 | 140 | 692 |
| Total Volume | 0 | 277 | 211 | 234 | 722 | 0 | 18 | 285 | 404 | 707 | 0 | 84 | 543 | 28 | 655 | 0 | 427 | 133 | 2 | 562 | 2646 |
| % App. Total | 0 | 38.4 | 29.2 | 32.4 | | 0 | 2.5 | 40.3 | 57.1 | | 0 | 12.8 | 82.9 | 4.3 | | 0 | 76 | 23.7 | 0.4 | | |
| PHF | .000 | .866 | .894 | .770 | .916 | .000 | .375 | .810 | .802 | .884 | .000 | .750 | .956 | .583 | .920 | .000 | .905 | .594 | .500 | .918 | .937 |

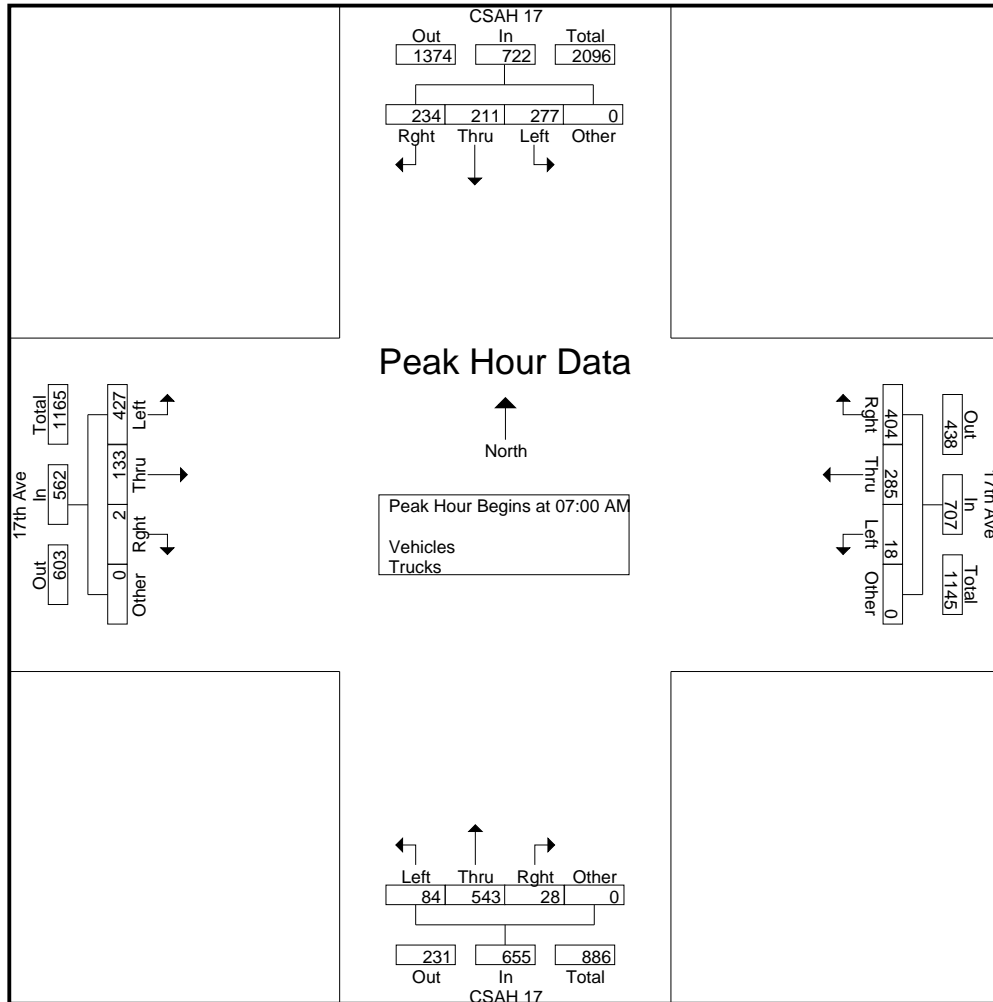

Alliant Engineering, Inc

233 Park Ave Suite 300
 Minneapolis, MN 55415
 --TRAFFIC DATA --

CSAH-17 at 17th Avenue
 Ref.Pt.: Not Available
 data by : Alliant Inc.
TURN MOVEMENT COUNT

File Name : 331_CSAH 17 & 17th Ave
 Site Code : 331
 Start Date : 11/8/2017
 Page No : 4

| Start Time | CSAH 17 From North | | | | | 17th Ave From East | | | | | CSAH 17 From South | | | | | 17th Ave From West | | | | | Int. Total |
|--|--------------------|------|------|------|------------|--------------------|------|------|------|------------|--------------------|------|------|------|------------|--------------------|------|------|------|------------|------------|
| | Other | Left | Thru | Rght | App. Total | Other | Left | Thru | Rght | App. Total | Other | Left | Thru | Rght | App. Total | Other | Left | Thru | Rght | App. Total | |
| Peak Hour Analysis From 12:00 PM to 05:45 PM - Peak 1 of 1 | | | | | | | | | | | | | | | | | | | | | |
| Peak Hour for Entire Intersection Begins at 04:15 PM | | | | | | | | | | | | | | | | | | | | | |
| 04:15 PM | 0 | 140 | 104 | 91 | 335 | 0 | 15 | 87 | 96 | 198 | 0 | 8 | 99 | 1 | 108 | 0 | 66 | 47 | 5 | 118 | 759 |
| 04:30 PM | 0 | 120 | 133 | 83 | 336 | 0 | 13 | 90 | 96 | 199 | 0 | 7 | 64 | 0 | 71 | 0 | 69 | 61 | 6 | 136 | 742 |
| 04:45 PM | 1 | 121 | 148 | 92 | 362 | 0 | 16 | 62 | 130 | 208 | 0 | 12 | 105 | 2 | 119 | 0 | 66 | 61 | 3 | 130 | 819 |
| 05:00 PM | 0 | 129 | 145 | 105 | 379 | 0 | 12 | 80 | 101 | 193 | 0 | 4 | 74 | 0 | 78 | 0 | 74 | 55 | 4 | 133 | 783 |
| Total Volume | 1 | 510 | 530 | 371 | 1412 | 0 | 56 | 319 | 423 | 798 | 0 | 31 | 342 | 3 | 376 | 0 | 275 | 224 | 18 | 517 | 3103 |
| % App. Total | 0.1 | 36.1 | 37.5 | 26.3 | | 0 | 7 | 40 | 53 | | 0 | 8.2 | 91 | 0.8 | | 0 | 53.2 | 43.3 | 3.5 | | |
| PHF | .250 | .911 | .895 | .883 | .931 | .000 | .875 | .886 | .813 | .959 | .000 | .646 | .814 | .375 | .790 | .000 | .929 | .918 | .750 | .950 | .947 |

