

Alliant Engineering

Minneapolis, MN 55415

--TRAFFIC DATA --

TH-10 at Main St (ELK RIVER)

Ref.Pt.:

Alliant Eng.

TURN MOVEMENT COUNT

File Name : 404_TH 10 & Main St

Site Code : 404

Start Date : 3/8/2016

Page No : 1

Groups Printed- Vehicles - Trucks

Start Time	Main St (ELK RIVER) Southbound				TH-10 Westbound				Main St (ELK RIVER) Northbound				TH-10 Eastbound				Int. Total
	Left	Thru	Rght	Other	Left	Thru	Rght	Other	Left	Thru	Rght	Other	Left	Thru	Rght	Other	
06:00	3	3	13	0	2	65	4	0	2	4	19	0	11	9	0	0	135
06:15	12	5	16	0	0	83	8	0	3	12	39	0	18	9	1	0	206
06:30	15	9	13	0	7	72	6	0	3	15	37	0	47	421	2	0	647
06:45	10	12	20	0	11	132	8	0	0	20	34	0	26	384	1	0	658
Total	40	29	62	0	20	352	26	0	8	51	129	0	102	823	4	0	1646
07:00	15	17	9	0	8	107	4	0	2	8	44	0	33	406	2	0	655
07:15	13	13	9	0	12	148	8	0	3	17	45	0	23	427	0	0	718
07:30	14	22	23	0	18	151	9	0	0	32	34	0	39	390	2	0	734
07:45	12	25	19	0	16	145	8	0	5	49	42	0	39	371	3	0	734
Total	54	77	60	0	54	551	29	0	10	106	165	0	134	1594	7	0	2841
08:00	16	26	9	0	13	128	13	0	5	24	22	0	30	233	0	0	519
08:15	16	20	19	0	6	92	7	0	4	15	26	0	32	257	3	0	497
08:30	10	30	14	0	11	135	5	0	6	26	31	0	22	200	3	0	493
08:45	11	31	24	0	17	104	5	0	3	28	33	0	39	205	1	0	501
Total	53	107	66	0	47	459	30	0	18	93	112	0	123	895	7	0	2010
09:00	11	29	19	0	10	91	14	0	2	31	17	0	32	211	5	0	472
09:15	11	38	20	0	14	122	9	0	2	17	22	0	26	159	3	0	443
*** BREAK ***																	
Total	22	67	39	0	24	213	23	0	4	48	39	0	58	370	8	0	915
*** BREAK ***																	
10:30	8	43	23	0	11	115	14	0	6	30	20	0	12	143	3	0	428
10:45	4	33	25	0	21	91	11	0	1	37	17	0	39	123	3	0	405
Total	12	76	48	0	32	206	25	0	7	67	37	0	51	266	6	0	833
11:00	13	21	18	0	10	98	10	0	3	37	15	0	37	134	5	0	401
11:15	9	35	40	0	9	114	8	0	4	35	22	0	39	131	3	0	449
11:30	8	32	41	0	14	97	14	0	3	38	21	0	55	143	9	0	475
11:45	26	41	48	0	11	124	8	0	4	38	20	0	49	135	8	0	512
Total	56	129	147	0	44	433	40	0	14	148	78	0	180	543	25	0	1837
12:00	6	28	44	0	14	129	9	0	3	34	22	0	48	100	6	0	443
12:15	12	40	43	0	11	115	10	0	1	44	14	0	43	140	3	0	476
12:30	10	36	35	0	21	133	9	0	3	33	12	0	33	106	3	0	434
12:45	21	42	41	0	28	147	10	0	6	44	18	0	40	142	1	0	540
Total	49	146	163	0	74	524	38	0	13	155	66	0	164	488	13	0	1893
13:00	9	32	33	0	18	144	10	0	6	50	11	0	36	145	3	0	497
13:15	16	26	55	0	18	133	10	0	2	39	23	0	40	117	5	0	484
*** BREAK ***																	
Total	25	58	88	0	36	277	20	0	8	89	34	0	76	262	8	0	981
*** BREAK ***																	
14:30	10	42	44	0	24	234	15	0	4	46	13	0	42	160	4	0	638
14:45	12	42	54	0	23	270	17	0	1	40	22	0	47	143	5	0	676
Total	22	84	98	0	47	504	32	0	5	86	35	0	89	303	9	0	1314
15:00	13	48	54	0	32	290	12	0	4	54	15	0	39	161	4	0	726
15:15	15	43	47	0	38	293	11	0	5	48	11	0	38	129	3	0	681
15:30	5	43	55	0	27	292	17	0	5	33	19	0	55	189	8	0	748
15:45	8	35	61	0	37	328	19	0	6	40	27	0	50	172	6	3	792
Total	41	169	217	0	134	1203	59	0	20	175	72	0	182	651	21	3	2947
16:00	10	44	47	0	37	363	28	0	8	61	18	0	46	181	7	0	850
16:15	16	55	60	0	28	292	29	0	6	49	19	0	55	155	6	0	770
16:30	13	47	59	0	32	387	14	0	2	41	19	0	44	200	10	1	869

Alliant Engineering

Minneapolis, MN 55415

--TRAFFIC DATA --

TH-10 at Main St (ELK RIVER)

Ref.Pt.:

Alliant Eng.

TURN MOVEMENT COUNT

File Name : 404_TH 10 & Main St

Site Code : 404

Start Date : 3/8/2016

Page No : 2

Groups Printed- Vehicles - Trucks

Start Time	Main St (ELK RIVER) Southbound				TH-10 Westbound				Main St (ELK RIVER) Northbound				TH-10 Eastbound				Int. Total
	Left	Thru	Rght	Other	Left	Thru	Rght	Other	Left	Thru	Rght	Other	Left	Thru	Rght	Other	
16:45	9	47	55	0	30	378	16	0	5	64	22	0	50	189	4	0	869
Total	48	193	221	0	127	1420	87	0	21	215	78	0	195	725	27	1	3358
17:00	12	48	61	0	42	355	14	0	9	37	18	0	44	166	8	1	815
17:15	13	42	51	0	36	422	25	0	5	57	15	0	37	195	8	0	906
17:30	13	37	61	0	29	379	18	0	2	35	9	0	38	150	7	0	778
17:45	9	43	60	0	30	312	10	0	8	53	7	0	50	132	6	0	720
Total	47	170	233	0	137	1468	67	0	24	182	49	0	169	643	29	1	3219
Grand Total	469	1305	1442	0	776	7610	476	0	152	1415	894	0	1523	7563	164	5	23794
Apprch %	14.6	40.6	44.8	0	8.8	85.9	5.4	0	6.2	57.5	36.3	0	16.5	81.7	1.8	0.1	
Total %	2	5.5	6.1	0	3.3	32	2	0	0.6	5.9	3.8	0	6.4	31.8	0.7	0	
Vehicles	459	1267	1409	0	768	7230	446	0	114	1099	786	0	1454	7246	162	4	22444
% Vehicles	97.9	97.1	97.7	0	99	95	93.7	0	75	77.7	87.9	0	95.5	95.8	98.8	80	94.3
Trucks	10	38	33	0	8	380	30	0	38	316	108	0	69	317	2	1	1350
% Trucks	2.1	2.9	2.3	0	1	5	6.3	0	25	22.3	12.1	0	4.5	4.2	1.2	20	5.7

Alliant Engineering

Minneapolis, MN 55415

--TRAFFIC DATA --

TH-10 at Main St (ELK RIVER)

Ref.Pt.:

Alliant Eng.

TURN MOVEMENT COUNT

File Name : 404_TH 10 & Main St

Site Code : 404

Start Date : 3/8/2016

Page No : 3

Start Time	Main St (ELK RIVER) Southbound					TH-10 Westbound					Main St (ELK RIVER) Northbound					TH-10 Eastbound					Int. Total
	Left	Thru	Rght	Other	App. Total	Left	Thru	Rght	Other	App. Total	Left	Thru	Rght	Other	App. Total	Left	Thru	Rght	Other	App. Total	
Peak Hour Analysis From 06:00 to 11:45 - Peak 1 of 1																					
Peak Hour for Entire Intersection Begins at 07:00																					
07:00	15	17	9	0	41	8	107	4	0	119	2	8	44	0	54	33	406	2	0	441	655
07:15	13	13	9	0	35	12	148	8	0	168	3	17	45	0	65	23	427	0	0	450	718
07:30	14	22	23	0	59	18	151	9	0	178	0	32	34	0	66	39	390	2	0	431	734
07:45	12	25	19	0	56	16	145	8	0	169	5	49	42	0	96	39	371	3	0	413	734
Total Volume	54	77	60	0	191	54	551	29	0	634	10	106	165	0	281	134	1594	7	0	1735	2841
% App. Total	28.3	40.3	31.4	0		8.5	86.9	4.6	0		3.6	37.7	58.7	0		7.7	91.9	0.4	0		
PHF	.900	.770	.652	.000	.809	.750	.912	.806	.000	.890	.500	.541	.917	.000	.732	.859	.933	.583	.000	.964	.968

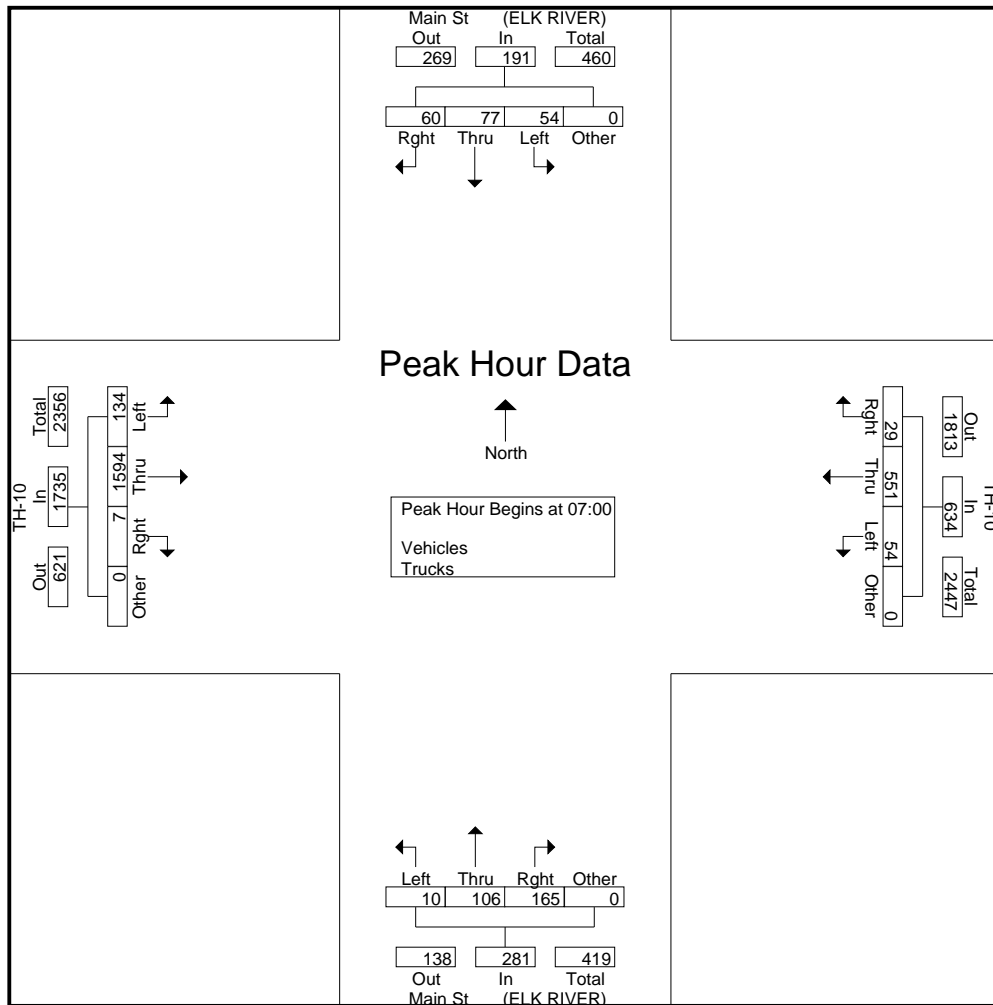

Alliant Engineering

Minneapolis, MN 55415

--TRAFFIC DATA --

TH-10 at Main St (ELK RIVER)

Ref.Pt.:

Alliant Eng.

TURN MOVEMENT COUNT

File Name : 404_TH 10 & Main St

Site Code : 404

Start Date : 3/8/2016

Page No : 4

Start Time	Main St (ELK RIVER) Southbound					TH-10 Westbound					Main St (ELK RIVER) Northbound					TH-10 Eastbound					Int. Total
	Left	Thru	Rght	Other	App. Total	Left	Thru	Rght	Other	App. Total	Left	Thru	Rght	Other	App. Total	Left	Thru	Rght	Other	App. Total	
Peak Hour Analysis From 12:00 to 17:45 - Peak 1 of 1																					
Peak Hour for Entire Intersection Begins at 16:30																					
16:30	13	47	59	0	119	32	387	14	0	433	2	41	19	0	62	44	200	10	1	255	869
16:45	9	47	55	0	111	30	378	16	0	424	5	64	22	0	91	50	189	4	0	243	869
17:00	12	48	61	0	121	42	355	14	0	411	9	37	18	0	64	44	166	8	1	219	815
17:15	13	42	51	0	106	36	422	25	0	483	5	57	15	0	77	37	195	8	0	240	906
Total Volume	47	184	226	0	457	140	1542	69	0	1751	21	199	74	0	294	175	750	30	2	957	3459
% App. Total	10.3	40.3	49.5	0		8	88.1	3.9	0		7.1	67.7	25.2	0		18.3	78.4	3.1	0.2		
PHF	.904	.958	.926	.000	.944	.833	.914	.690	.000	.906	.583	.777	.841	.000	.808	.875	.938	.750	.500	.938	.954

