



# MINNESOTA DEPT OF TRANSPORTATION

## TRAFFIC DATA COLLECTION - METRO

Loc: TH 10 @ ARMSTRONG BLVD 2006  
 REF. PT.: 220+00.290  
 JAMAR# T-1385/MAR  
 TURN MOVEMENT COUNT

File Name : TH 10 @ ARMSTRONG BLVD 2006  
 Site Code : 00000000  
 Start Date : 12/6/2006  
 Page No : 1

### Groups Printed- CARS & TRUCKS

Start Time	ARMSTRONG BLVD Southbound					TH 10 Westbound					ARMSTRONG BLVD Northbound					TH 10 Eastbound					Int. Total
	Left	Thru	Right	Peds	App. Total	Left	Thru	Right	Peds	App. Total	Left	Thru	Right	Peds	App. Total	Left	Thru	Right	Peds	App. Total	
06:00	77	0	15	0	92	0	97	2	0	99	0	0	1	0	1	7	399	0	0	406	598
06:15	61	0	13	0	74	1	123	4	0	128	0	0	0	0	0	14	501	0	0	515	717
06:30	56	1	15	0	72	2	207	14	0	223	0	1	4	0	5	19	464	1	0	484	784
06:45	38	1	8	0	47	8	200	16	0	224	1	1	3	0	5	23	425	1	0	449	725
Total	232	2	51	0	285	11	627	36	0	674	1	2	8	0	11	63	1789	2	0	1854	2824
07:00	79	0	14	0	93	7	126	6	0	139	0	2	1	1	4	19	416	1	0	436	672
07:15	51	4	16	0	71	4	234	15	0	253	0	2	4	0	6	21	444	1	0	466	796
07:30	51	6	16	0	73	7	232	16	0	255	1	0	0	0	1	22	459	5	0	486	815
07:45	33	5	11	0	49	3	226	19	0	248	0	0	0	0	0	34	345	4	0	383	680
Total	214	15	57	0	286	21	818	56	0	895	1	4	5	1	11	96	1664	11	0	1771	2963
08:00	43	5	16	0	64	4	217	16	0	237	0	0	2	0	2	25	360	4	0	389	692
08:15	37	4	14	0	55	7	146	9	0	162	1	0	1	0	2	18	327	3	0	348	567
08:30	54	0	25	0	79	5	188	15	0	208	2	0	0	0	2	12	309	1	0	322	611
08:45	38	0	22	0	60	5	201	13	0	219	0	0	6	0	6	16	331	2	0	349	634
Total	172	9	77	0	258	21	752	53	0	826	3	0	9	0	12	71	1327	10	0	1408	2504
11:00	17	1	19	0	37	4	227	24	0	255	1	2	5	0	8	8	258	1	0	267	567
11:15	36	0	19	0	55	4	151	27	0	182	1	0	5	0	6	11	211	2	0	224	467
11:30	28	2	18	0	48	7	214	1	0	222	3	1	2	0	6	19	217	4	0	240	516
11:45	30	2	17	0	49	4	190	32	0	226	3	2	1	0	6	11	211	3	0	225	506
Total	111	5	73	0	189	19	782	84	0	885	8	5	13	0	26	49	897	10	0	956	2056
12:00	25	5	13	0	43	9	233	35	0	277	1	3	1	0	5	16	225	4	0	245	570
12:15	23	1	19	0	43	12	214	36	0	262	3	2	2	0	7	22	248	0	0	270	582
12:30	28	7	22	0	57	5	250	22	0	277	1	1	2	0	4	17	218	1	0	236	574
12:45	21	2	19	0	42	7	220	28	0	255	1	3	1	0	5	8	210	5	0	223	525
Total	97	15	73	0	185	33	917	121	0	1071	6	9	6	0	21	63	901	10	0	974	2251
15:00	15	1	29	0	45	9	403	55	0	467	1	1	0	0	2	12	230	0	0	242	756
15:15	28	3	33	0	64	4	402	63	0	469	3	2	1	0	6	18	259	4	0	281	820
15:30	20	3	43	0	66	5	419	72	0	496	1	2	1	0	4	20	248	2	0	270	836
15:45	15	3	37	0	55	31	398	62	0	491	1	0	3	0	4	13	313	1	0	327	877
Total	78	10	142	0	230	49	1622	252	0	1923	6	5	5	0	16	63	1050	7	0	1120	3289
16:00	16	1	41	0	58	10	410	52	0	472	2	4	2	0	8	8	286	1	0	295	833
16:15	29	2	44	0	75	3	404	74	0	481	5	3	2	0	10	15	283	0	0	298	864
16:30	27	0	47	1	75	8	405	80	0	493	7	3	4	0	14	25	284	4	0	313	895
16:45	27	3	33	0	63	5	425	66	0	496	3	1	1	1	6	24	300	0	0	324	889
Total	99	6	165	1	271	26	1644	272	0	1942	17	11	9	1	38	72	1153	5	0	1230	3481
17:00	35	8	32	0	75	6	391	84	3	484	3	6	3	0	12	23	320	2	0	345	916
17:15	29	3	31	0	63	5	392	75	0	472	3	3	1	0	7	21	266	0	0	287	829
17:30	18	4	35	0	57	5	403	70	0	478	2	1	0	0	3	18	238	0	0	256	794
17:45	29	1	26	0	56	3	339	68	0	410	4	1	2	0	7	12	211	0	0	223	696
Total	111	16	124	0	251	19	1525	297	3	1844	12	11	6	0	29	74	1035	2	0	1111	3235
Grand Total	1114	78	762	1	1955	199	8687	1171	3	10060	54	47	61	2	164	551	9816	57	0	10424	22603
Apprch %	57	4	39	0.1		2	86.4	11.6	0		32.9	28.7	37.2	1.2		5.3	94.2	0.5	0		
Total %	4.9	0.3	3.4	0	8.6	0.9	38.4	5.2	0	44.5	0.2	0.2	0.3	0	0.7	2.4	43.4	0.3	0	46.1	



# MINNESOTA DEPT OF TRANSPORTATION

## TRAFFIC DATA COLLECTION - METRO

File Name : TH 10 @ ARMSTRONG BLVD 2006  
 Site Code : 00000000  
 Start Date : 12/6/2006  
 Page No : 2

Start Time	ARMSTRONG BLVD Southbound					TH 10 Westbound					ARMSTRONG BLVD Northbound					TH 10 Eastbound					Int. Total
	Left	Thru	Right	Peds	App. Total	Left	Thru	Right	Peds	App. Total	Left	Thru	Right	Peds	App. Total	Left	Thru	Right	Peds	App. Total	
Peak Hour Analysis From 06:00 to 08:45 - Peak 1 of 1																					
Peak Hour for Entire Intersection Begins at 06:45																					
06:45	38	1	8	0	47	8	200	16	0	224	1	1	3	0	5	23	425	1	0	449	725
07:00	79	0	14	0	93	7	126	6	0	139	0	2	1	1	4	19	416	1	0	436	672
07:15	51	4	16	0	71	4	234	15	0	253	0	2	4	0	6	21	444	1	0	466	796
07:30	51	6	16	0	73	7	232	16	0	255	1	0	0	0	1	22	459	5	0	486	815
Total Volume	219	11	54	0	284	26	792	53	0	871	2	5	8	1	16	85	1744	8	0	1837	3008
% App. Total	77.1	3.9	19	0		3	90.9	6.1	0		12.5	31.2	50	6.2		4.6	94.9	0.4	0		
PHF	.693	.458	.844	.000	.763	.813	.846	.828	.000	.854	.500	.625	.500	.250	.667	.924	.950	.400	.000	.945	.923

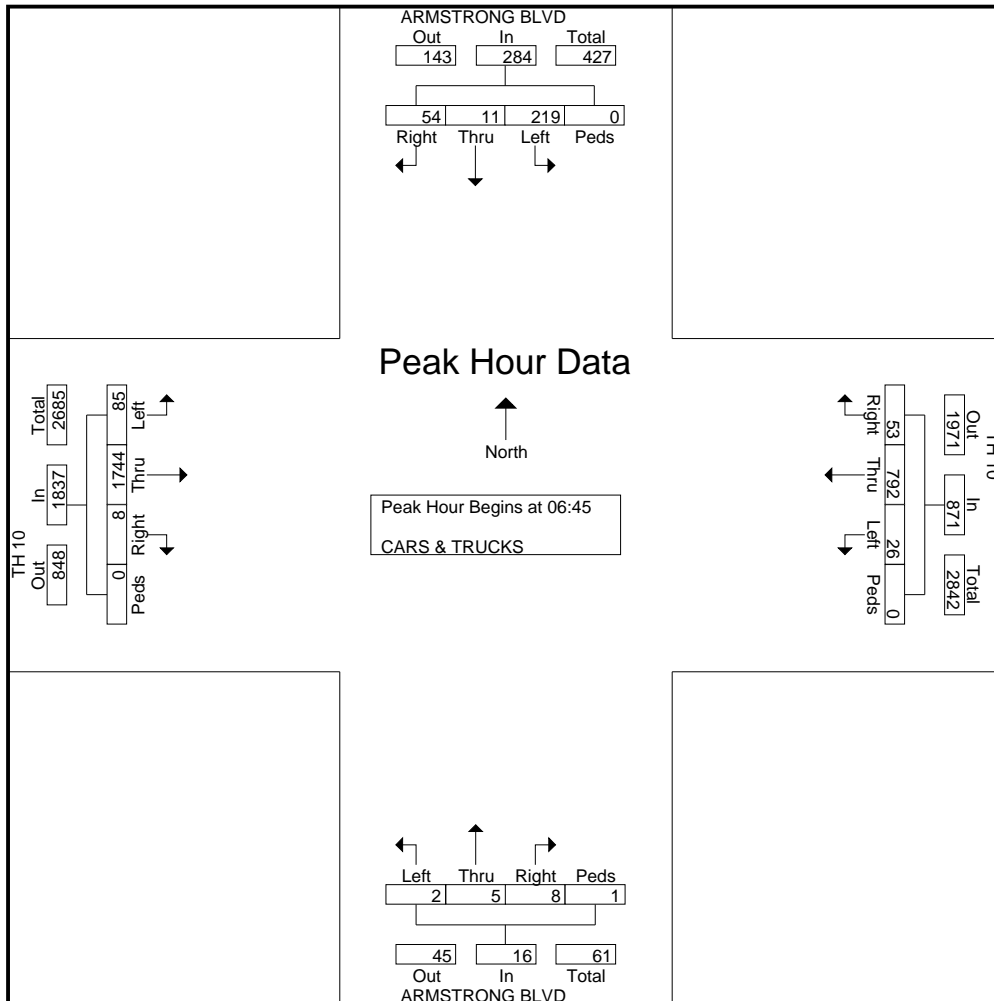



# MINNESOTA DEPT OF TRANSPORTATION

## TRAFFIC DATA COLLECTION - METRO

File Name : TH 10 @ ARMSTRONG BLVD 2006  
 Site Code : 00000000  
 Start Date : 12/6/2006  
 Page No : 3

Start Time	ARMSTRONG BLVD Southbound					TH 10 Westbound					ARMSTRONG BLVD Northbound					TH 10 Eastbound					Int. Total
	Left	Thru	Right	Peds	App. Total	Left	Thru	Right	Peds	App. Total	Left	Thru	Right	Peds	App. Total	Left	Thru	Right	Peds	App. Total	
Peak Hour Analysis From 11:00 to 13:00 - Peak 1 of 1																					
Peak Hour for Entire Intersection Begins at 12:00																					
12:00	25	5	13	0	43	9	233	35	0	277	1	3	1	0	5	16	225	4	0	245	570
12:15	23	1	19	0	43	12	214	36	0	262	3	2	2	0	7	22	248	0	0	270	582
12:30	28	7	22	0	57	5	250	22	0	277	1	1	2	0	4	17	218	1	0	236	574
12:45	21	2	19	0	42	7	220	28	0	255	1	3	1	0	5	8	210	5	0	223	525
Total Volume	97	15	73	0	185	33	917	121	0	1071	6	9	6	0	21	63	901	10	0	974	2251
% App. Total	52.4	8.1	39.5	0		3.1	85.6	11.3	0		28.6	42.9	28.6	0		6.5	92.5	1	0		
PHF	.866	.536	.830	.000	.811	.688	.917	.840	.000	.967	.500	.750	.750	.000	.750	.716	.908	.500	.000	.902	.967

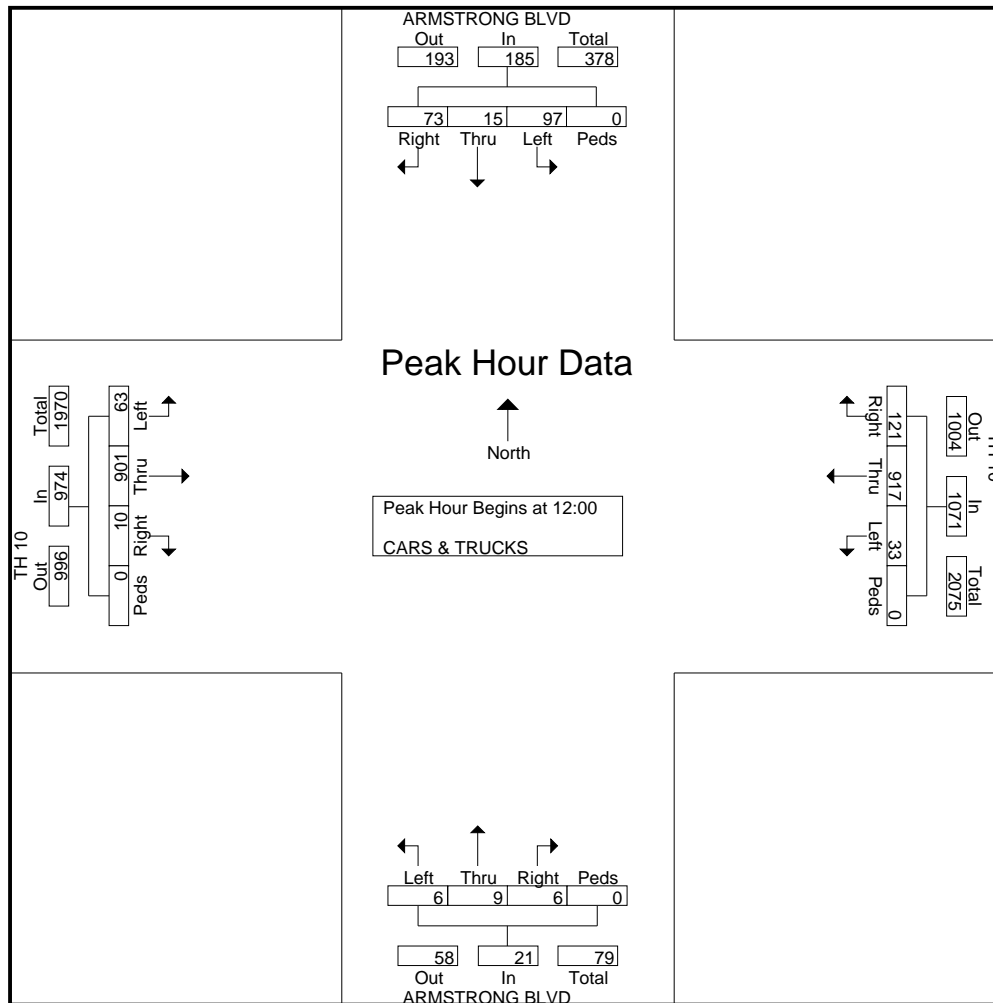



# MINNESOTA DEPT OF TRANSPORTATION

## TRAFFIC DATA COLLECTION - METRO

File Name : TH 10 @ ARMSTRONG BLVD 2006  
 Site Code : 00000000  
 Start Date : 12/6/2006  
 Page No : 4

Start Time	ARMSTRONG BLVD Southbound					TH 10 Westbound					ARMSTRONG BLVD Northbound					TH 10 Eastbound					Int. Total
	Left	Thru	Right	Peds	App. Total	Left	Thru	Right	Peds	App. Total	Left	Thru	Right	Peds	App. Total	Left	Thru	Right	Peds	App. Total	
16:15	29	2	44	0	75	3	404	74	0	481	5	3	2	0	10	15	283	0	0	298	864
16:30	27	0	47	1	75	8	405	80	0	493	7	3	4	0	14	25	284	4	0	313	895
16:45	27	3	33	0	63	5	425	66	0	496	3	1	1	1	6	24	300	0	0	324	889
17:00	35	8	32	0	75	6	391	84	3	484	3	6	3	0	12	23	320	2	0	345	916
Total Volume	118	13	156	1	288	22	1625	304	3	1954	18	13	10	1	42	87	1187	6	0	1280	3564
% App. Total	41	4.5	54.2	0.3		1.1	83.2	15.6	0.2		42.9	31	23.8	2.4		6.8	92.7	0.5	0		
PHF	.843	.406	.830	.250	.960	.688	.956	.905	.250	.985	.643	.542	.625	.250	.750	.870	.927	.375	.000	.928	.973

Peak Hour Analysis From 15:00 to 17:45 - Peak 1 of 1  
 Peak Hour for Entire Intersection Begins at 16:15

