

Associated Consulting Services (ASC)
 Saint Paul, MN 55127
 -- TRAFFIC DATA --

TH-95 at 70th St_2019
 Ref Pt: 122+00.456
 Data Prepared By: ACS
 TURNING MOVEMENT COUNT

File Name : TH-95 at 70th St_2019
 Site Code :
 Start Date : 12/18/2019
 Page No : 1

Groups Printed- Cars - Trucks

Start Time	TH-95 South Bound				70th St West Bound				TH-95 North Bound				70th St East Bound				Int. Total
	Right	Thru	Left	Peds	Right	Thru	Left	Peds	Right	Thru	Left	Peds	Right	Thru	Left	Peds	
06:00 AM	12	6	0	0	2	6	3	0	0	12	0	0	0	1	6	0	48
06:15 AM	18	17	1	0	3	8	3	0	0	22	3	0	1	4	12	0	92
06:30 AM	25	24	2	0	4	10	2	0	2	31	1	0	0	6	21	0	128
06:45 AM	25	16	1	0	0	16	3	0	0	21	2	0	1	4	14	0	103
Total	80	63	4	0	9	40	11	0	2	86	6	0	2	15	53	0	371
07:00 AM	14	24	5	0	3	8	5	0	1	30	1	0	2	6	30	0	129
07:15 AM	26	25	0	0	1	18	6	0	2	24	5	0	0	9	31	0	147
07:30 AM	30	38	5	0	2	18	3	0	2	28	3	0	0	3	34	0	166
07:45 AM	28	35	4	0	6	13	5	0	1	24	4	0	3	4	16	0	143
Total	98	122	14	0	12	57	19	0	6	106	13	0	5	22	111	0	585
08:00 AM	16	18	1	0	2	11	3	0	3	34	2	0	1	2	21	0	114
08:15 AM	10	20	7	0	7	10	5	0	3	24	2	0	0	7	10	0	105
08:30 AM	9	16	8	0	5	16	4	0	2	17	4	0	2	9	14	0	106
08:45 AM	11	20	9	0	4	7	4	0	5	27	4	0	2	7	15	0	115
Total	46	74	25	0	18	44	16	0	13	102	12	0	5	25	60	0	440
09:00 AM	0	16	3	0	3	8	3	0	1	21	0	0	3	10	10	0	78
09:15 AM	5	15	4	0	1	12	1	0	1	20	0	0	0	11	6	0	76
09:30 AM	11	14	4	0	2	8	3	0	1	23	3	0	0	9	11	0	89
09:45 AM	5	21	7	0	4	6	2	0	0	19	3	0	3	7	7	0	84
Total	21	66	18	0	10	34	9	0	3	83	6	0	6	37	34	0	327
10:00 AM	5	16	5	0	4	6	1	0	1	13	1	0	1	4	10	0	67
10:15 AM	8	15	2	0	1	7	2	0	0	22	3	0	1	6	7	0	74
10:30 AM	13	14	11	0	3	7	1	0	0	15	1	0	4	5	7	0	81
10:45 AM	12	20	0	0	3	6	1	0	2	16	3	0	1	4	9	0	77
Total	38	65	18	0	11	26	5	0	3	66	8	0	7	19	33	0	299
11:00 AM	7	18	3	0	6	8	6	0	5	22	3	0	2	7	5	0	92
11:15 AM	7	23	4	0	7	6	2	0	1	21	3	0	1	9	5	0	89
11:30 AM	6	12	3	0	2	6	2	0	3	21	1	0	2	7	8	0	73
11:45 AM	9	22	5	0	2	6	2	0	2	20	2	0	2	3	7	0	82
Total	29	75	15	0	17	26	12	0	11	84	9	0	7	26	25	0	336
12:00 PM	5	17	5	0	2	8	0	0	3	16	2	0	1	8	5	0	72
12:15 PM	10	26	5	0	5	4	2	0	5	21	4	0	2	5	15	0	104
12:30 PM	5	22	7	0	2	11	2	0	1	22	5	0	1	5	8	0	91
12:45 PM	10	15	4	0	4	6	2	0	2	32	2	0	2	6	11	0	96
Total	30	80	21	0	13	29	6	0	11	91	13	0	6	24	39	0	363
01:00 PM	6	15	4	0	5	6	6	0	1	13	2	0	3	10	6	0	77
01:15 PM	11	30	7	0	6	5	0	0	2	27	0	0	1	7	2	0	98
01:30 PM	3	17	4	0	8	5	1	0	1	19	2	0	3	8	13	0	84
01:45 PM	6	14	6	0	5	8	1	0	2	27	2	0	1	5	14	0	91
Total	26	76	21	0	24	24	8	0	6	86	6	0	8	30	35	0	350

Associated Consulting Services (ASC)
 Saint Paul, MN 55127
 -- TRAFFIC DATA --

TH-95 at 70th St_2019
 Ref Pt: 122+00.456
 Data Prepared By: ACS
 TURNING MOVEMENT COUNT

File Name : TH-95 at 70th St_2019
 Site Code :
 Start Date : 12/18/2019
 Page No : 2

Groups Printed- Cars - Trucks

Start Time	TH-95 South Bound				70th St West Bound				TH-95 North Bound				70th St East Bound				Int. Total
	Right	Thru	Left	Peds	Right	Thru	Left	Peds	Right	Thru	Left	Peds	Right	Thru	Left	Peds	
02:00 PM	5	22	6	0	2	9	3	0	1	24	1	0	1	13	11	0	98
02:15 PM	12	19	6	0	7	11	6	0	1	21	0	0	1	9	8	0	101
02:30 PM	14	35	12	0	4	7	6	0	1	24	1	0	1	4	10	0	119
02:45 PM	24	34	15	0	5	17	3	0	4	30	1	0	0	16	18	0	167
Total	55	110	39	0	18	44	18	0	7	99	3	0	3	42	47	0	485
03:00 PM	13	28	13	0	2	13	3	0	5	21	1	0	6	21	9	0	135
03:15 PM	15	29	14	0	6	12	3	0	3	27	5	0	4	25	23	0	166
03:30 PM	17	24	16	0	7	12	3	0	5	24	0	0	5	20	20	0	153
03:45 PM	23	37	18	0	12	10	3	0	6	35	0	0	5	20	28	0	197
Total	68	118	61	0	27	47	12	0	19	107	6	0	20	86	80	0	651
04:00 PM	19	31	15	0	16	18	3	0	5	36	1	0	6	21	24	0	195
04:15 PM	26	44	10	0	14	18	6	0	0	30	5	0	4	12	23	0	192
04:30 PM	22	29	6	0	6	19	4	0	3	34	1	0	2	20	28	0	174
04:45 PM	35	40	12	0	7	15	4	0	4	48	1	0	8	22	26	0	222
Total	102	144	43	0	43	70	17	0	12	148	8	0	20	75	101	0	783
05:00 PM	19	29	9	0	9	12	2	0	6	40	2	0	3	16	21	0	168
05:15 PM	15	43	13	0	9	16	1	0	4	24	1	0	4	29	18	0	177
05:30 PM	15	50	17	0	5	13	4	0	5	31	7	0	3	24	13	0	187
05:45 PM	11	20	14	0	11	14	1	0	5	29	2	0	2	19	12	0	140
Total	60	142	53	0	34	55	8	0	20	124	12	0	12	88	64	0	672
Grand Total	653	1135	332	0	236	496	141	0	113	1182	102	0	101	489	682	0	5662
Apprch %	30.8	53.5	15.7	0	27	56.8	16.2	0	8.1	84.6	7.3	0	7.9	38.4	53.6	0	
Total %	11.5	20	5.9	0	4.2	8.8	2.5	0	2	20.9	1.8	0	1.8	8.6	12	0	
Cars	634	1069	318	0	227	474	138	0	110	1097	96	0	99	483	655	0	5400
% Cars	97.1	94.2	95.8	0	96.2	95.6	97.9	0	97.3	92.8	94.1	0	98	98.8	96	0	95.4
Trucks	19	66	14	0	9	22	3	0	3	85	6	0	2	6	27	0	262
% Trucks	2.9	5.8	4.2	0	3.8	4.4	2.1	0	2.7	7.2	5.9	0	2	1.2	4	0	4.6

Associated Consulting Services (ASC)
 Saint Paul, MN 55127
 -- TRAFFIC DATA --

TH-95 at 70th St_2019
 Ref Pt: 122+00.456
 Data Prepared By: ACS
 TURNING MOVEMENT COUNT

File Name : TH-95 at 70th St_2019
 Site Code :
 Start Date : 12/18/2019
 Page No : 3

Start Time	TH-95 South Bound					70th St West Bound					TH-95 North Bound					70th St East Bound					Int. Total
	Right	Thru	Left	Peds	App. Total	Right	Thru	Left	Peds	App. Total	Right	Thru	Left	Peds	App. Total	Right	Thru	Left	Peds	App. Total	
Peak Hour Analysis From 06:00 AM to 11:45 AM - Peak 1 of 1																					
Peak Hour for Entire Intersection Begins at 07:00 AM																					
07:00 AM	14	24	5	0	43	3	8	5	0	16	1	30	1	0	32	2	6	30	0	38	129
07:15 AM	26	25	0	0	51	1	18	6	0	25	2	24	5	0	31	0	9	31	0	40	147
07:30 AM	30	38	5	0	73	2	18	3	0	23	2	28	3	0	33	0	3	34	0	37	166
07:45 AM	28	35	4	0	67	6	13	5	0	24	1	24	4	0	29	3	4	16	0	23	143
Total Volume	98	122	14	0	234	12	57	19	0	88	6	106	13	0	125	5	22	111	0	138	585
% App. Total	41.9	52.1	6	0		13.6	64.8	21.6	0		4.8	84.8	10.4	0		3.6	15.9	80.4	0		
PHF	.817	.803	.700	.000	.801	.500	.792	.792	.000	.880	.750	.883	.650	.000	.947	.417	.611	.816	.000	.863	.881

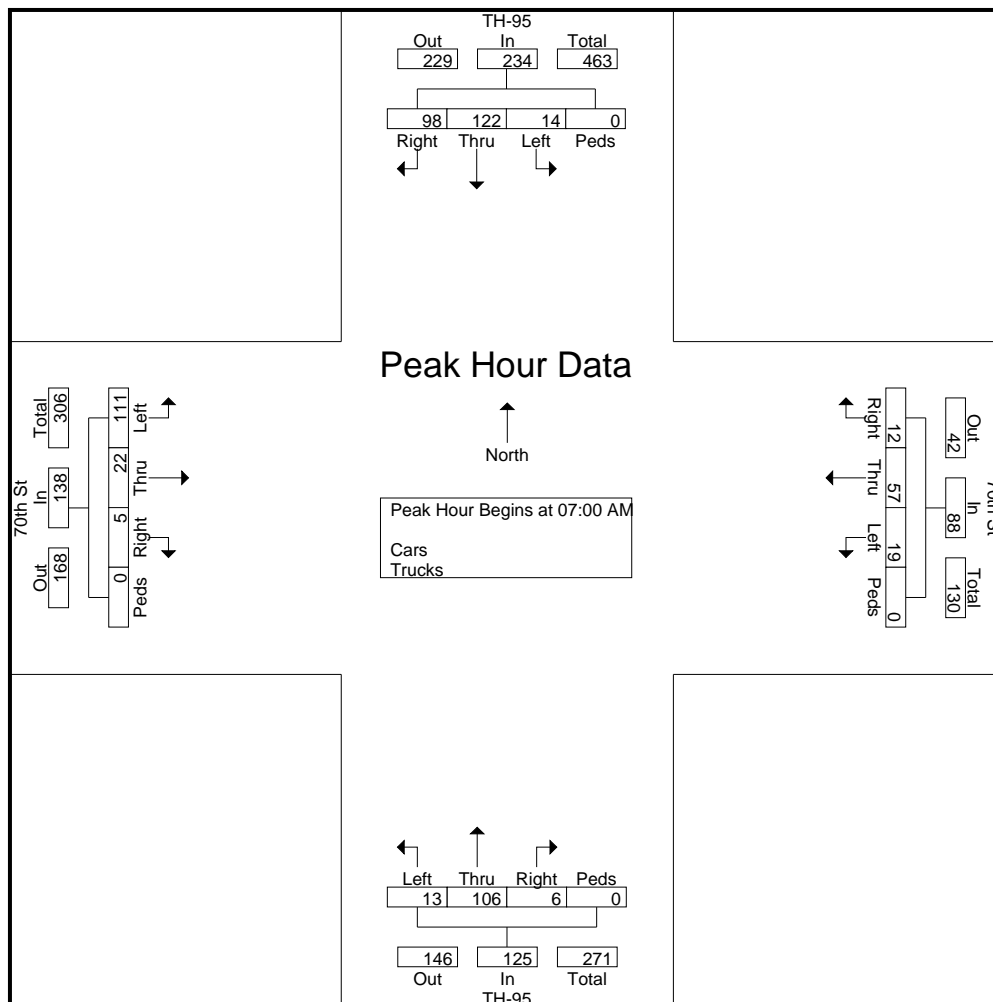

Associated Consulting Services (ASC)
 Saint Paul, MN 55127
 -- TRAFFIC DATA --

TH-95 at 70th St_2019
 Ref Pt: 122+00.456
 Data Prepared By: ACS
 TURNING MOVEMENT COUNT

File Name : TH-95 at 70th St_2019
 Site Code :
 Start Date : 12/18/2019
 Page No : 4

Start Time	TH-95 South Bound					70th St West Bound					TH-95 North Bound					70th St East Bound					Int. Total
	Right	Thru	Left	Peds	App. Total	Right	Thru	Left	Peds	App. Total	Right	Thru	Left	Peds	App. Total	Right	Thru	Left	Peds	App. Total	
Peak Hour Analysis From 12:00 PM to 05:45 PM - Peak 1 of 1																					
Peak Hour for Entire Intersection Begins at 04:00 PM																					
04:00 PM	19	31	15	0	65	16	18	3	0	37	5	36	1	0	42	6	21	24	0	51	195
04:15 PM	26	44	10	0	80	14	18	6	0	38	0	30	5	0	35	4	12	23	0	39	192
04:30 PM	22	29	6	0	57	6	19	4	0	29	3	34	1	0	38	2	20	28	0	50	174
04:45 PM	35	40	12	0	87	7	15	4	0	26	4	48	1	0	53	8	22	26	0	56	222
Total Volume	102	144	43	0	289	43	70	17	0	130	12	148	8	0	168	20	75	101	0	196	783
% App. Total	35.3	49.8	14.9	0		33.1	53.8	13.1	0		7.1	88.1	4.8	0		10.2	38.3	51.5	0		
PHF	.729	.818	.717	.000	.830	.672	.921	.708	.000	.855	.600	.771	.400	.000	.792	.625	.852	.902	.000	.875	.882

