

SEH CONSULTING
Traffic Data Collection
TURN MOVEMENT COUNT

TH-95 at Chestnut St. STILLWATER
Ref.Pt.: 104.141
data by SEH
TURN MOVEMENT COUNT

File Name : TH-95 at Chestnut St 2008
Site Code : 00000012
Start Date : 12/10/2008
Page No : 1

Groups Printed- Unshifted - Heavy Veh

Start Time	TH-95 / S Main St. Southbound				Chestnut St / TH-36 Westbound				TH-95 / TH-36 / S Main St. Northbound				Chestnut St Eastbound				Int. Total
	Left	Thru	Right	Peds	Left	Thru	Right	Peds	Left	Thru	Right	Peds	Left	Thru	Right	Peds	
06:00	2	40	1	0	200	27	11	0	0	11	11	0	0	2	6	0	311
06:15	4	47	0	0	208	39	18	0	0	13	22	0	0	6	10	0	367
06:30	5	48	2	0	205	50	25	0	0	14	36	0	0	5	5	0	395
06:45	10	52	3	0	196	71	23	0	0	19	41	0	0	12	3	0	430
Total	21	187	6	0	809	187	77	0	0	57	110	0	0	25	24	0	1503
07:00	15	62	1	0	190	62	21	0	0	22	33	0	0	13	1	0	420
07:15	14	50	3	0	171	75	27	0	0	22	40	0	0	13	1	0	416
07:30	10	67	5	0	171	77	29	1	0	28	37	0	1	17	3	0	446
07:45	10	61	9	0	167	82	34	1	0	31	30	0	2	15	3	0	445
Total	49	240	18	0	699	296	111	2	0	103	140	0	3	58	8	0	1727
08:00	14	39	8	0	144	68	27	2	0	26	29	2	1	9	4	0	373
08:15	5	41	11	0	152	54	18	1	0	53	33	0	5	13	2	1	389
08:30	18	59	9	0	82	46	17	1	2	37	40	0	1	13	2	2	329
08:45	12	49	3	1	86	63	21	0	1	58	40	0	2	20	5	0	361
Total	49	188	31	1	464	231	83	4	3	174	142	2	9	55	13	3	1452
*** BREAK ***																	
11:00	14	32	2	3	55	27	11	4	0	40	43	0	3	24	3	1	262
11:15	8	38	2	2	72	24	20	1	0	44	48	0	1	18	7	3	288
11:30	10	37	1	3	70	27	10	5	1	48	64	2	4	24	5	4	315
11:45	14	44	3	0	71	18	8	4	1	51	44	0	5	13	2	5	283
Total	46	151	8	8	268	96	49	14	2	183	199	2	13	79	17	13	1148
12:00	14	36	3	2	64	22	9	4	0	34	57	2	4	26	7	6	290
12:15	8	44	5	1	55	22	17	3	1	33	56	2	2	18	10	5	282
12:30	11	57	6	0	63	24	11	1	3	47	64	2	3	31	4	2	329
12:45	14	56	5	1	66	25	11	2	1	51	51	0	0	25	5	3	316
Total	47	193	19	4	248	93	48	10	5	165	228	6	9	100	26	16	1217
*** BREAK ***																	
15:00	24	43	5	0	38	18	12	3	0	53	125	0	2	60	3	0	386
15:15	35	47	9	1	67	37	16	3	0	53	106	0	2	84	2	0	462
15:30	18	56	7	1	47	25	9	0	0	53	132	0	4	70	4	2	428
15:45	23	37	5	0	50	38	14	2	0	43	129	3	2	100	2	3	451
Total	100	183	26	2	202	118	51	8	0	202	492	3	10	314	11	5	1727
16:00	30	47	5	0	58	22	13	4	0	47	140	3	1	94	2	0	466
16:15	33	50	4	0	65	37	15	0	0	55	121	0	2	103	4	2	491
16:30	44	42	8	0	42	33	14	0	2	41	146	0	1	96	4	5	478
16:45	39	47	9	0	41	24	5	0	0	32	140	0	0	118	0	1	456
Total	146	186	26	0	206	116	47	4	2	175	547	3	4	411	10	8	1891
17:00	41	55	8	5	57	43	14	0	1	43	139	2	7	86	5	5	511
17:15	43	52	5	0	58	30	15	3	0	34	138	2	2	112	3	5	502
17:30	30	34	6	0	60	25	17	0	0	44	144	0	2	69	8	4	443
17:45	41	53	0	0	40	22	18	1	0	48	121	1	3	86	4	7	445
Total	155	194	19	5	215	120	64	4	1	169	542	5	14	353	20	21	1901
Grand Total	613	1522	153	20	3111	1257	530	46	13	1228	2400	21	62	1395	129	66	12566
Apprch %	26.6	65.9	6.6	0.9	62.9	25.4	10.7	0.9	0.4	33.5	65.5	0.6	3.8	84.4	7.8	4	
Total %	4.9	12.1	1.2	0.2	24.8	10	4.2	0.4	0.1	9.8	19.1	0.2	0.5	11.1	1	0.5	
Unshifted	611	1498	153	20	3096	1257	530	46	13	1216	2387	21	62	1391	128	66	12495
% Unshifted	99.7	98.4	100	100	99.5	100	100	100	100	99	99.5	100	100	99.7	99.2	100	99.4
Heavy Veh	2	24	0	0	15	0	0	0	0	12	13	0	0	4	1	0	71
% Heavy Veh	0.3	1.6	0	0	0.5	0	0	0	0	1	0.5	0	0	0.3	0.8	0	0.6

SEH CONSULTING
Traffic Data Collection
TURN MOVEMENT COUNT

TH-95 at Chestnut St. STILLWATER
Ref.Pt.: 104.141
data by SEH
TURN MOVEMENT COUNT

File Name : TH-95 at Chestnut St 2008
Site Code : 00000012
Start Date : 12/10/2008
Page No : 2

Start Time	TH-95 / S Main St. Southbound					Chestnut St / TH-36 Westbound					TH-95 / TH-36 / S Main St. Northbound					Chestnut St Eastbound					Int. Total
	Left	Thru	Right	Peds	App. Total	Left	Thru	Right	Peds	App. Total	Left	Thru	Right	Peds	App. Total	Left	Thru	Right	Peds	App. Total	
Peak Hour Analysis From 06:00 to 08:45 - Peak 1 of 1																					
Peak Hour for Entire Intersection Begins at 07:00																					
07:00	15	62	1	0	78	190	62	21	0	273	0	22	33	0	55	0	13	1	0	14	420
07:15	14	50	3	0	67	171	75	27	0	273	0	22	40	0	62	0	13	1	0	14	416
07:30	10	67	5	0	82	171	77	29	1	278	0	28	37	0	65	1	17	3	0	21	446
07:45	10	61	9	0	80	167	82	34	1	284	0	31	30	0	61	2	15	3	0	20	445
Total Volume	49	240	18	0	307	699	296	111	2	1108	0	103	140	0	243	3	58	8	0	69	1727
% App. Total	16	78.2	5.9	0		63.1	26.7	10	0.2		0	42.4	57.6	0		4.3	84.1	11.6	0		
PHF	.817	.896	.500	.000	.936	.920	.902	.816	.500	.975	.000	.831	.875	.000	.935	.375	.853	.667	.000	.821	.968

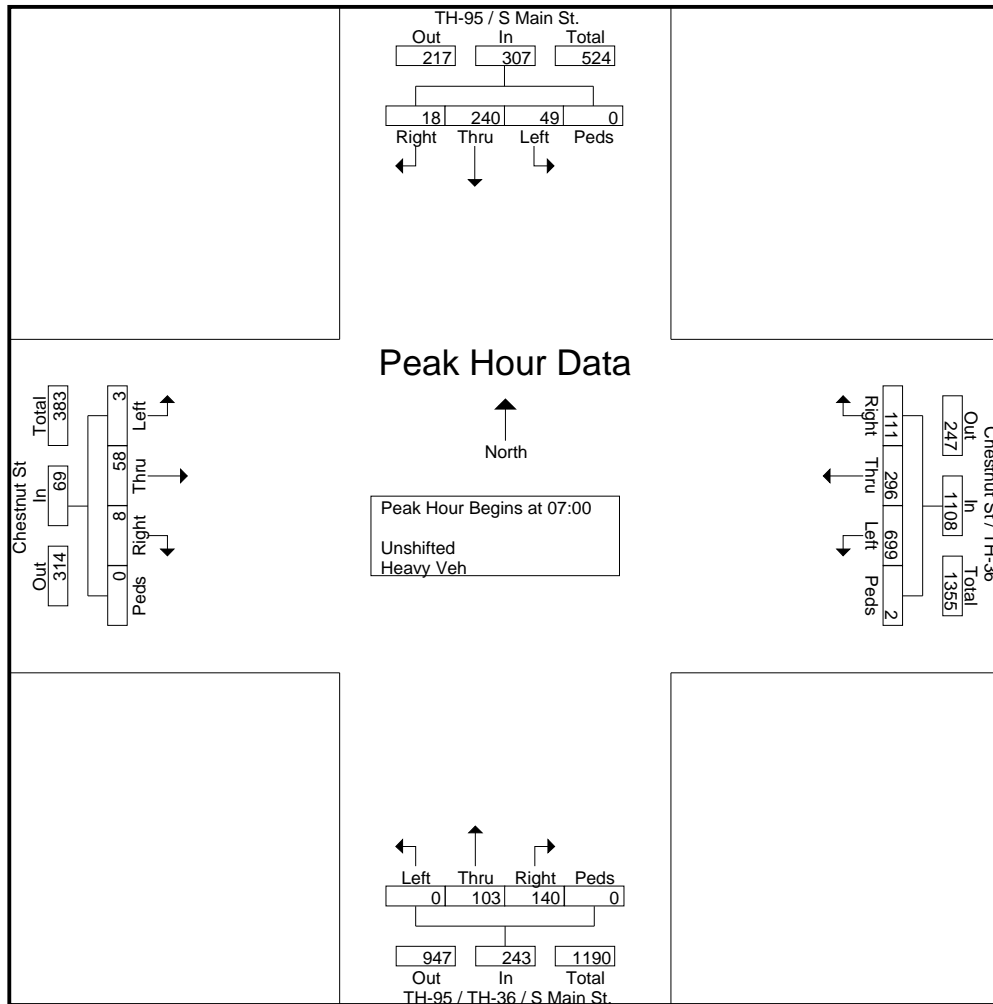

SEH CONSULTING
Traffic Data Collection
TURN MOVEMENT COUNT

TH-95 at Chestnut St. STILLWATER
Ref.Pt.: 104.141
data by SEH
TURN MOVEMENT COUNT

File Name : TH-95 at Chestnut St 2008
Site Code : 00000012
Start Date : 12/10/2008
Page No : 3

Start Time	TH-95 / S Main St. Southbound					Chestnut St / TH-36 Westbound					TH-95 / TH-36 / S Main St. Northbound					Chestnut St Eastbound					Int. Total
	Left	Thru	Right	Peds	App. Total	Left	Thru	Right	Peds	App. Total	Left	Thru	Right	Peds	App. Total	Left	Thru	Right	Peds	App. Total	
16:30	44	42	8	0	94	42	33	14	0	89	2	41	146	0	189	1	96	4	5	106	478
16:45	39	47	9	0	95	41	24	5	0	70	0	32	140	0	172	0	118	0	1	119	456
17:00	41	55	8	5	109	57	43	14	0	114	1	43	139	2	185	7	86	5	5	103	511
17:15	43	52	5	0	100	58	30	15	3	106	0	34	138	2	174	2	112	3	5	122	502
Total Volume	167	196	30	5	398	198	130	48	3	379	3	150	563	4	720	10	412	12	16	450	1947
% App. Total	42	49.2	7.5	1.3		52.2	34.3	12.7	0.8		0.4	20.8	78.2	0.6		2.2	91.6	2.7	3.6		
PHF	.949	.891	.833	.250	.913	.853	.756	.800	.250	.831	.375	.872	.964	.500	.952	.357	.873	.600	.800	.922	.953

Peak Hour Analysis From 15:00 to 17:45 - Peak 1 of 1
Peak Hour for Entire Intersection Begins at 16:30

