

MN Dept of Transportation

TRAFFIC DATA COLLECTION - Metro

TH-7 at Wooddale Ave , North Ramps
 Ref.Pt.; 193.705
 video RE
 TURN MOVEMENT COUNT

File Name : TH-7 at Wooddale Ave North Ramps 2014
 Site Code :
 Start Date : 12/4/2014
 Page No : 1

Groups Printed- Cars +

Start Time	Wooddale Ave Southbound				ramp from WB TH-7 Westbound				Wooddale Ave Northbound				ramp to WB TH-7 Eastbound				Int. Total
	Left	Thru	Right	Peds	Left	Thru	Right	Peds	Left	Thru	Right	Peds	Left	Thru	Right	Peds	
06:00	0	25	3	0	11	0	13	0	4	11	0	0	0	0	0	0	67
06:15	0	28	10	0	17	0	12	0	16	15	0	0	0	0	0	0	98
06:30	0	47	17	0	22	0	13	0	21	27	0	0	0	0	0	0	147
06:45	0	64	8	0	22	0	20	0	31	36	0	0	0	0	0	0	181
Total	0	164	38	0	72	0	58	0	72	89	0	0	0	0	0	0	493
07:00	0	85	19	0	20	0	22	0	55	63	0	0	0	0	0	0	264
07:15	0	96	22	0	31	0	24	0	45	92	0	0	0	0	0	0	310
07:30	0	119	29	0	18	0	19	0	52	110	0	0	0	0	0	0	347
07:45	0	130	27	0	17	1	19	0	88	128	0	0	0	0	0	0	410
Total	0	430	97	0	86	1	84	0	240	393	0	0	0	0	0	0	1331
08:00	0	125	25	0	23	0	35	0	60	107	0	0	0	0	0	0	375
08:15	0	136	25	0	16	0	29	0	55	108	0	0	0	0	0	0	369
08:30	0	122	30	0	17	0	22	0	46	89	0	0	0	0	0	0	326
08:45	0	85	23	0	17	0	13	0	44	60	0	0	0	0	0	0	242
Total	0	468	103	0	73	0	99	0	205	364	0	0	0	0	0	0	1312
*****BREAK*****																	
15:00	0	112	41	0	17	0	26	0	45	107	0	0	0	0	0	0	348
15:15	0	141	30	0	11	0	29	0	54	101	0	0	0	0	0	0	366
15:30	0	99	17	0	23	0	20	0	55	117	0	0	0	0	0	0	331
15:45	0	85	13	0	9	0	17	0	66	109	0	0	0	0	0	0	299
Total	0	437	101	0	60	0	92	0	220	434	0	0	0	0	0	0	1344
16:00	0	96	17	0	23	1	30	0	96	130	0	0	0	0	0	0	393
16:15	0	101	27	0	15	0	12	0	68	150	0	0	0	0	0	0	373
16:30	0	83	12	0	15	0	20	0	82	142	0	0	0	0	0	0	354
16:45	0	100	16	0	20	0	19	0	85	146	0	0	0	0	0	0	386
Total	0	380	72	0	73	1	81	0	331	568	0	0	0	0	0	0	1506
17:00	0	136	19	0	9	1	17	0	90	179	0	0	0	0	0	0	451
17:15	0	101	18	0	18	0	25	0	93	177	0	0	0	0	0	0	432
17:30	0	140	16	0	10	0	28	0	88	175	0	0	0	0	0	0	457
17:45	0	114	21	0	13	0	21	0	70	191	0	0	0	0	0	0	430
Total	0	491	74	0	50	1	91	0	341	722	0	0	0	0	0	0	1770
Grand Total	0	2370	485	0	414	3	505	0	1409	2570	0	0	0	0	0	0	7756
Apprch %	0	83	17	0	44.9	0.3	54.8	0	35.4	64.6	0	0	0	0	0	0	
Total %	0	30.6	6.3	0	5.3	0	6.5	0	18.2	33.1	0	0	0	0	0	0	

MN Dept of Transportation

TRAFFIC DATA COLLECTION - Metro

TH-7 at Wooddale Ave , North Ramps
 Ref.Pt.; 193.705
 video RE
 TURN MOVEMENT COUNT

File Name : TH-7 at Wooddale Ave North Ramps 2014
 Site Code :
 Start Date : 12/4/2014
 Page No : 2

Start Time	Wooddale Ave Southbound					ramp from WB TH-7 Westbound					Wooddale Ave Northbound					ramp to WB TH-7 Eastbound					Int. Total
	Left	Thru	Right	Peds	App. Total	Left	Thru	Right	Peds	App. Total	Left	Thru	Right	Peds	App. Total	Left	Thru	Right	Peds	App. Total	
Peak Hour Analysis From 06:00 to 08:45 - Peak 1 of 1																					
Peak Hour for Entire Intersection Begins at 07:30																					
07:30	0	119	29	0	148	18	0	19	0	37	52	110	0	0	162	0	0	0	0	0	347
07:45	0	130	27	0	157	17	1	19	0	37	88	128	0	0	216	0	0	0	0	0	410
08:00	0	125	25	0	150	23	0	35	0	58	60	107	0	0	167	0	0	0	0	0	375
08:15	0	136	25	0	161	16	0	29	0	45	55	108	0	0	163	0	0	0	0	0	369
Total Volume	0	510	106	0	616	74	1	102	0	177	255	453	0	0	708	0	0	0	0	0	1501
% App. Total	0	82.8	17.2	0		41.8	0.6	57.6	0		36	64	0	0		0	0	0	0	0	
PHF	.000	.938	.914	.000	.957	.804	.250	.729	.000	.763	.724	.885	.000	.000	.819	.000	.000	.000	.000	.000	.915

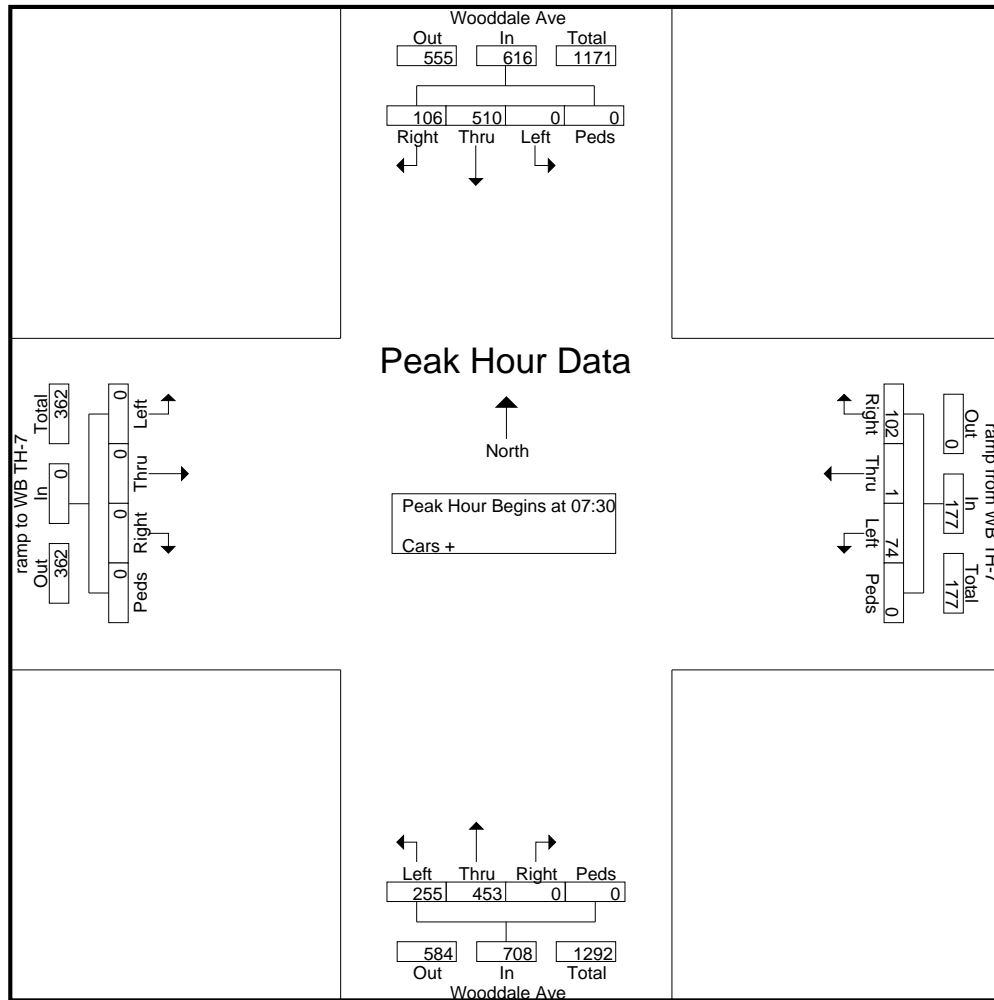

MN Dept of Transportation

TRAFFIC DATA COLLECTION - Metro

TH-7 at Wooddale Ave , North Ramps
 Ref.Pt.; 193.705
 video RE
 TURN MOVEMENT COUNT

File Name : TH-7 at Wooddale Ave North Ramps 2014
 Site Code :
 Start Date : 12/4/2014
 Page No : 3

Start Time	Wooddale Ave Southbound					ramp from WB TH-7 Westbound					Wooddale Ave Northbound					ramp to WB TH-7 Eastbound					Int. Total
	Left	Thru	Right	Peds	App. Total	Left	Thru	Right	Peds	App. Total	Left	Thru	Right	Peds	App. Total	Left	Thru	Right	Peds	App. Total	
Peak Hour Analysis From 15:00 to 17:45 - Peak 1 of 1																					
Peak Hour for Entire Intersection Begins at 17:00																					
17:00	0	136	19	0	155	9	1	17	0	27	90	179	0	0	269	0	0	0	0	0	451
17:15	0	101	18	0	119	18	0	25	0	43	93	177	0	0	270	0	0	0	0	0	432
17:30	0	140	16	0	156	10	0	28	0	38	88	175	0	0	263	0	0	0	0	0	457
17:45	0	114	21	0	135	13	0	21	0	34	70	191	0	0	261	0	0	0	0	0	430
Total Volume	0	491	74	0	565	50	1	91	0	142	341	722	0	0	1063	0	0	0	0	0	1770
% App. Total	0	86.9	13.1	0		35.2	0.7	64.1	0		32.1	67.9	0	0		0	0	0	0		
PHF	.000	.877	.881	.000	.905	.694	.250	.813	.000	.826	.917	.945	.000	.000	.984	.000	.000	.000	.000	.000	.968

