

Alliant Engineering Inc Minneapolis, MN 55415

TH-65 at 99th Ave NE BLAINE
Ref.Pt.: 012.164
data by Alliant Engineering Inc
TURN MOVEMENT COUNT

File Name : TH-65 at 99th Ave NE 2009
Site Code : 00000014
Start Date : 1/13/2009
Page No : 1

Groups Printed- Unshifted

Start Time	TH-65 Southbound				99th Ave NE Westbound				TH-65 Northbound				99th Ave NE Eastbound				Int. Total
	Left	Thru	Right	Peds	Left	Thru	Right	Peds	Left	Thru	Right	Peds	Left	Thru	Right	Peds	
06:00	4	401	20	0	4	2	0	0	4	71	0	0	12	10	25	0	553
06:15	0	435	25	0	6	4	0	0	4	106	0	0	14	16	37	0	647
06:30	1	490	26	0	16	5	0	0	8	102	2	0	17	12	24	0	703
06:45	3	331	23	0	31	17	0	0	6	135	2	0	29	29	31	0	637
Total	8	1657	94	0	57	28	0	0	22	414	4	0	72	67	117	0	2540
07:00	5	392	17	0	30	14	0	0	5	117	3	0	12	13	26	0	634
07:15	1	371	20	0	42	21	0	0	5	151	3	0	18	19	17	0	668
07:30	5	345	28	0	23	22	0	0	8	191	3	0	24	11	27	2	689
07:45	2	404	34	0	35	14	0	0	8	193	0	0	26	20	20	0	756
Total	13	1512	99	0	130	71	0	0	26	652	9	0	80	63	90	2	2747
08:00	4	371	25	0	35	19	0	0	8	133	3	0	19	23	16	0	656
08:15	4	389	34	0	44	17	0	0	17	163	2	0	23	12	26	0	731
08:30	6	376	25	0	30	19	0	0	6	152	3	0	15	23	29	0	684
08:45	1	351	28	0	33	9	0	0	13	197	1	0	24	10	20	0	687
Total	15	1487	112	0	142	64	0	0	44	645	9	0	81	68	91	0	2758
09:00	7	329	41	0	29	14	0	0	15	183	1	0	26	15	37	0	697
09:15	4	319	37	0	18	6	0	0	16	168	4	0	15	10	21	0	618
*** BREAK ***																	
Total	11	648	78	0	47	20	0	0	31	351	5	0	41	25	58	0	1315
*** BREAK ***																	
10:30	4	0	34	0	17	9	0	0	17	191	2	0	17	5	13	0	309
10:45	7	199	19	0	12	13	0	0	9	212	8	0	24	12	24	0	539
Total	11	199	53	0	29	22	0	0	26	403	10	0	41	17	37	0	848
11:00	5	184	17	0	8	17	9	0	21	188	14	0	18	9	9	0	499
11:15	5	243	19	0	30	10	4	0	20	247	10	0	13	9	20	0	630
11:30	5	236	20	1	29	25	4	0	10	209	12	0	23	13	15	0	602
11:45	14	208	22	0	27	20	6	0	19	262	5	0	22	19	16	0	640
Total	29	871	78	1	94	72	23	0	70	906	41	0	76	50	60	0	2371
12:00	10	190	35	0	23	27	4	0	21	241	12	0	33	14	17	0	627
12:15	9	264	23	0	36	23	4	0	22	308	4	0	27	21	14	1	756
12:30	8	240	27	0	30	28	0	0	13	247	10	0	34	12	14	0	663
12:45	5	249	30	0	21	18	5	0	20	287	8	0	36	15	13	0	707
Total	32	943	115	0	110	96	13	0	76	1083	34	0	130	62	58	1	2753
13:00	4	232	19	0	35	26	0	3	12	212	9	0	15	10	14	0	591
13:15	3	251	17	0	24	19	6	0	7	283	3	0	31	14	13	0	671
*** BREAK ***																	
Total	7	483	36	0	59	45	6	3	19	495	12	0	46	24	27	0	1262
*** BREAK ***																	
14:30	5	273	22	0	22	28	7	0	17	428	4	0	19	5	8	0	838
14:45	5	256	31	0	31	18	4	0	26	493	5	0	34	14	12	0	929
Total	10	529	53	0	53	46	11	0	43	921	9	0	53	19	20	0	1767
15:00	6	252	23	0	25	23	6	0	31	455	9	0	38	9	8	0	885
15:15	9	234	34	0	26	20	5	0	27	475	6	0	30	15	9	0	890
15:30	4	216	35	0	31	47	3	0	36	516	5	0	40	21	11	0	965
15:45	6	235	31	0	32	31	9	0	17	523	5	0	42	24	14	0	969
Total	25	937	123	0	114	121	23	0	111	1969	25	0	150	69	42	0	3709

Alliant Engineering Inc Minneapolis, MN 55415

TH-65 at 99th Ave NE BLAINE
 Ref.Pt.: 012.164
 data by Alliant Engineering Inc
 TURN MOVEMENT COUNT

File Name : TH-65 at 99th Ave NE 2009
 Site Code : 00000014
 Start Date : 1/13/2009
 Page No : 2

Groups Printed- Unshifted

Start Time	TH-65 Southbound				99th Ave NE Westbound				TH-65 Northbound				99th Ave NE Eastbound				Int. Total
	Left	Thru	Right	Peds	Left	Thru	Right	Peds	Left	Thru	Right	Peds	Left	Thru	Right	Peds	
16:00	5	180	48	0	21	30	7	0	21	548	5	0	23	23	15	0	926
16:15	9	229	41	0	33	37	4	0	22	547	8	0	46	36	20	0	1032
16:30	6	228	42	0	39	46	4	0	30	530	13	0	45	18	17	0	1018
16:45	7	282	40	0	28	55	13	0	27	546	5	0	49	33	19	0	1104
Total	27	919	171	0	121	168	28	0	100	2171	31	0	163	110	71	0	4080
17:00	9	268	46	0	23	47	11	0	36	486	4	0	49	24	6	0	1009
17:15	5	289	43	0	25	26	5	0	29	485	1	0	46	28	12	0	994
17:30	7	258	39	0	23	27	7	0	35	460	3	0	46	20	12	0	937
17:45	6	263	22	0	25	32	3	0	38	480	2	0	48	21	14	0	954
Total	27	1078	150	0	96	132	26	0	138	1911	10	0	189	93	44	0	3894
Grand Total	215	11263	1162	1	1052	885	130	3	706	11921	199	0	1122	667	715	3	30044
Apprch %	1.7	89.1	9.2	0	50.8	42.8	6.3	0.1	5.5	92.9	1.6	0	44.8	26.6	28.5	0.1	
Total %	0.7	37.5	3.9	0	3.5	2.9	0.4	0	2.3	39.7	0.7	0	3.7	2.2	2.4	0	

Alliant Engineering Inc Minneapolis, MN 55415

TH-65 at 99th Ave NE BLAINE
 Ref.Pt.: 012.164
 data by Alliant Engineering Inc
 TURN MOVEMENT COUNT

File Name : TH-65 at 99th Ave NE 2009
 Site Code : 00000014
 Start Date : 1/13/2009
 Page No : 3

Start Time	TH-65 Southbound					99th Ave NE Westbound					TH-65 Northbound					99th Ave NE Eastbound					Int. Total
	Left	Thru	Right	Peds	App. Total	Left	Thru	Right	Peds	App. Total	Left	Thru	Right	Peds	App. Total	Left	Thru	Right	Peds	App. Total	
Peak Hour Analysis From 06:00 to 08:45 - Peak 1 of 1																					
Peak Hour for Entire Intersection Begins at 07:30																					
07:30	5	345	28	0	378	23	22	0	0	45	8	191	3	0	202	24	11	27	2	64	689
07:45	2	404	34	0	440	35	14	0	0	49	8	193	0	0	201	26	20	20	0	66	756
08:00	4	371	25	0	400	35	19	0	0	54	8	133	3	0	144	19	23	16	0	58	656
08:15	4	389	34	0	427	44	17	0	0	61	17	163	2	0	182	23	12	26	0	61	731
Total Volume	15	1509	121	0	1645	137	72	0	0	209	41	680	8	0	729	92	66	89	2	249	2832
% App. Total	0.9	91.7	7.4	0		65.6	34.4	0	0		5.6	93.3	1.1	0		36.9	26.5	35.7	0.8		
PHF	.750	.934	.890	.000	.935	.778	.818	.000	.000	.857	.603	.881	.667	.000	.902	.885	.717	.824	.250	.943	.937

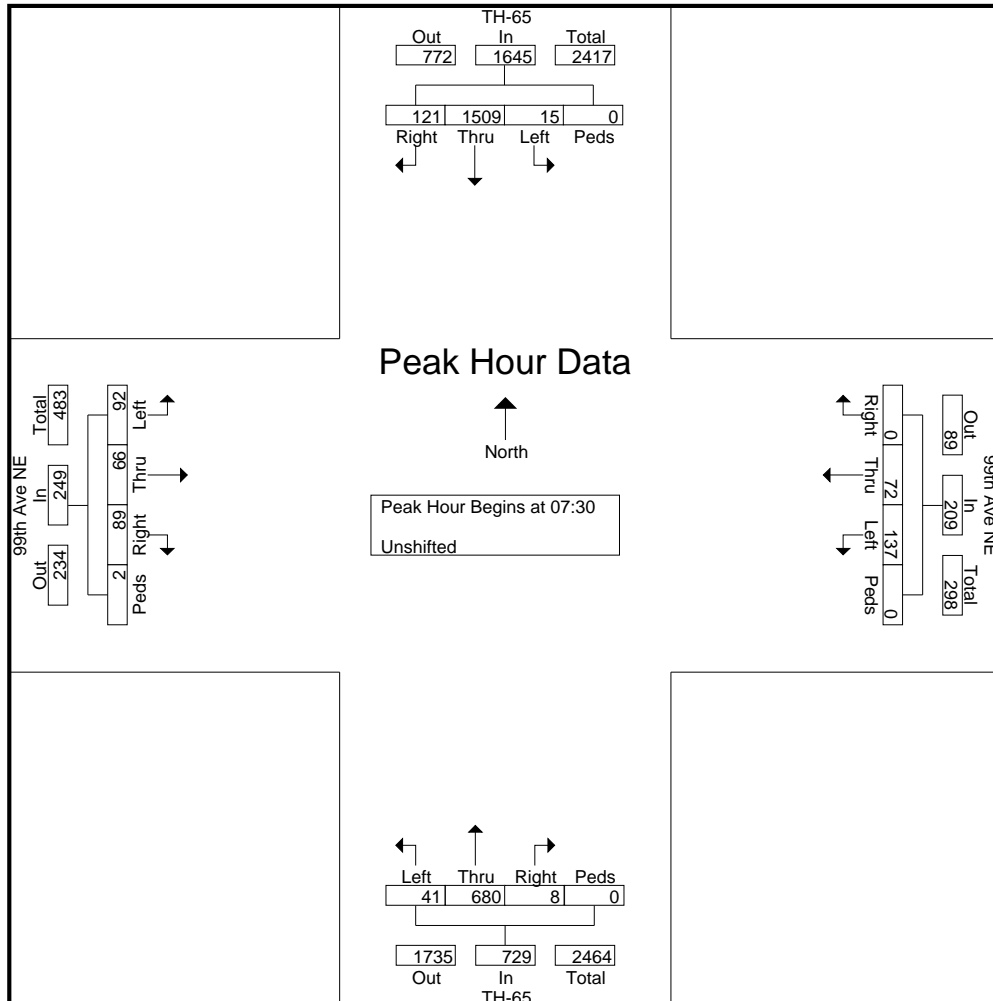

Alliant Engineering Inc Minneapolis, MN 55415

TH-65 at 99th Ave NE BLAINE
 Ref.Pt.: 012.164
 data by Alliant Engineering Inc
 TURN MOVEMENT COUNT

File Name : TH-65 at 99th Ave NE 2009
 Site Code : 00000014
 Start Date : 1/13/2009
 Page No : 4

Start Time	TH-65 Southbound					99th Ave NE Westbound					TH-65 Northbound					99th Ave NE Eastbound					Int. Total
	Left	Thru	Right	Peds	App. Total	Left	Thru	Right	Peds	App. Total	Left	Thru	Right	Peds	App. Total	Left	Thru	Right	Peds	App. Total	
Peak Hour Analysis From 15:00 to 17:45 - Peak 1 of 1																					
Peak Hour for Entire Intersection Begins at 16:15																					
16:15	9	229	41	0	279	33	37	4	0	74	22	547	8	0	577	46	36	20	0	102	1032
16:30	6	228	42	0	276	39	46	4	0	89	30	530	13	0	573	45	18	17	0	80	1018
16:45	7	282	40	0	329	28	55	13	0	96	27	546	5	0	578	49	33	19	0	101	1104
17:00	9	268	46	0	323	23	47	11	0	81	36	486	4	0	526	49	24	6	0	79	1009
Total Volume	31	1007	169	0	1207	123	185	32	0	340	115	2109	30	0	2254	189	111	62	0	362	4163
% App. Total	2.6	83.4	14	0		36.2	54.4	9.4	0		5.1	93.6	1.3	0		52.2	30.7	17.1	0		
PHF	.861	.893	.918	.000	.917	.788	.841	.615	.000	.885	.799	.964	.577	.000	.975	.964	.771	.775	.000	.887	.943

