

Alliant Engineering Inc Minneapolis, MN 55415

CSAH-62 at Baker Rd / CSAH-60

Ref.Pt.:

Alliant Engineering Inc

TURN MOVEMENT COUNT

File Name : 28_TH 62 at Baker Rd_030210

Site Code : 00000028

Start Date : 3/2/2010

Page No : 1

Groups Printed- Unshifted - Bank 1

Start Time	Baker Rd (Co Rd 60) Southbound				CSAH-62 / W 62nd St Westbound				Baker Rd (Co Rd 60) Northbound				CSAH-62 / W 62nd St Eastbound				Int. Total	
	Left	Thru	Right	Peds	Left	Thru	Right	Peds	Left	Thru	Right	Peds	Left	Thru	Right	Peds		
06:00	12	4	0	0	22	28	17	0	3	2	18	0	1	91	5	0	203	
06:15	6	9	2	0	24	36	21	0	4	12	48	0	2	140	11	0	315	
06:30	17	2	0	0	28	47	37	0	9	10	66	0	2	210	13	0	441	
06:45	18	10	1	0	28	85	55	2	10	24	78	0	4	298	17	0	630	
Total	53	25	3	0	102	196	130	2	26	48	210	0	9	739	46	0	1589	
07:00	26	15	3	0	28	73	18	0	11	24	127	0	4	307	10	1	647	
07:15	27	9	2	0	29	104	36	0	13	40	144	0	11	433	15	0	863	
07:30	41	19	2	0	36	102	51	0	18	34	136	0	14	408	15	0	876	
07:45	54	34	1	0	46	99	59	0	19	50	163	0	15	453	19	0	1012	
Total	148	77	8	0	139	378	164	0	61	148	570	0	44	1601	59	1	3398	
08:00	23	21	4	0	56	128	83	0	15	34	121	0	6	317	14	0	822	
08:15	25	22	0	0	71	126	65	0	17	36	100	0	16	256	11	0	745	
08:30	23	9	1	0	48	75	59	0	10	19	87	0	12	250	5	0	598	
08:45	20	15	3	0	52	72	39	0	10	22	69	0	3	196	10	0	511	
Total	91	67	8	0	227	401	246	0	52	111	377	0	37	1019	40	0	2676	
09:00	29	10	2	0	78	80	32	0	7	27	65	0	3	156	12	0	501	
09:15	29	15	7	0	0	0	0	0	0	0	0	0	5	127	15	0	198	
*** BREAK ***																		
Total	58	25	9	0	78	80	32	0	7	27	65	0	8	283	27	0	699	
*** BREAK ***																		
10:30	0	0	0	0	37	57	22	0	18	14	89	0	1	12	0	0	250	
10:45	6	9	0	0	41	71	20	0	16	11	82	0	6	45	6	0	313	
Total	6	9	0	0	78	128	42	0	34	25	171	0	7	57	6	0	563	
11:00	23	20	1	0	50	81	20	0	11	17	50	0	5	90	12	0	380	
11:15	38	19	3	0	42	92	21	0	18	14	56	0	4	105	11	0	423	
11:30	35	21	4	0	54	110	24	0	12	20	49	0	6	99	24	0	458	
11:45	43	34	1	0	73	106	33	2	21	23	58	0	10	81	24	0	509	
Total	139	94	9	0	219	389	98	2	62	74	213	0	25	375	71	0	1770	
12:00	26	31	4	0	50	94	31	1	13	29	67	0	3	95	14	0	458	
12:15	23	14	2	0	41	102	28	0	23	18	67	0	10	101	20	0	449	
12:30	35	24	3	0	36	117	35	1	25	28	62	0	2	112	16	0	496	
12:45	25	21	11	0	39	93	31	0	17	26	59	0	8	114	11	0	455	
Total	109	90	20	0	166	406	125	2	78	101	255	0	23	422	61	0	1858	
13:00	22	21	2	0	48	94	36	0	17	28	69	0	10	80	7	0	434	
13:15	22	15	5	0	41	101	24	0	25	25	61	0	6	103	14	0	442	
*** BREAK ***																		
Total	44	36	7	0	89	195	60	0	42	53	130	0	16	183	21	0	876	
*** BREAK ***																		
14:30	27	15	4	0	43	129	22	1	22	14	29	0	5	160	27	0	498	
14:45	23	19	6	0	47	157	24	0	18	19	43	0	3	124	24	0	507	
Total	50	34	10	0	90	286	46	1	40	33	72	0	8	284	51	0	1005	
15:00	40	13	5	0	52	166	36	0	25	21	57	0	6	135	18	0	574	
15:15	32	22	10	0	54	177	38	0	23	20	35	0	4	107	21	0	543	
15:30	49	26	8	0	76	198	30	0	23	30	52	0	9	131	23	0	655	
15:45	44	27	15	0	54	200	24	0	29	24	48	1	4	86	20	0	576	
Total	165	88	38	0	236	741	128	0	100	95	192	1	23	459	82	0	2348	

Alliant Engineering Inc Minneapolis, MN 55415

CSAH-62 at Baker Rd / CSAH-60
Ref.Pt.:
Alliant Engineering Inc
TURN MOVEMENT COUNT

File Name : 28_TH 62 at Baker Rd_030210
Site Code : 00000028
Start Date : 3/2/2010
Page No : 2

Groups Printed- Unshifted - Bank 1

Start Time	Baker Rd (Co Rd 60) Southbound				CSAH-62 / W 62nd St Westbound				Baker Rd (Co Rd 60) Northbound				CSAH-62 / W 62nd St Eastbound				Int. Total
	Left	Thru	Right	Peds	Left	Thru	Right	Peds	Left	Thru	Right	Peds	Left	Thru	Right	Peds	
16:00	48	40	15	1	97	229	18	0	26	27	40	0	7	166	23	0	737
16:15	38	33	18	0	84	265	27	0	12	27	57	1	9	103	27	0	701
16:30	60	47	13	0	85	317	33	0	23	26	49	0	16	160	23	0	852
16:45	53	31	24	0	122	325	29	0	29	37	46	0	14	96	30	0	836
Total	199	151	70	1	388	1136	107	0	90	117	192	1	46	525	103	0	3126
17:00	76	51	22	0	111	357	25	0	22	32	51	0	13	118	31	0	909
17:15	41	44	17	0	136	429	19	0	27	31	44	0	8	108	27	0	931
17:30	45	52	18	0	102	314	22	1	28	24	62	2	6	100	23	0	799
17:45	32	24	14	1	102	317	19	0	29	20	53	0	8	116	26	0	761
Total	194	171	71	1	451	1417	85	1	106	107	210	2	35	442	107	0	3400
Grand Total	1256	867	253	2	2263	5753	1263	8	698	939	2657	4	281	6389	674	1	23308
Apprch %	52.8	36.5	10.6	0.1	24.4	61.9	13.6	0.1	16.2	21.8	61.8	0.1	3.8	87	9.2	0	
Total %	5.4	3.7	1.1	0	9.7	24.7	5.4	0	3	4	11.4	0	1.2	27.4	2.9	0	
Unshifted	1214	856	244	2	2217	5601	1182	8	681	924	2604	4	271	6286	638	1	22733
% Unshifted	96.7	98.7	96.4	100	98	97.4	93.6	100	97.6	98.4	98	100	96.4	98.4	94.7	100	97.5
Bank 1	42	11	9	0	46	152	81	0	17	15	53	0	10	103	36	0	575
% Bank 1	3.3	1.3	3.6	0	2	2.6	6.4	0	2.4	1.6	2	0	3.6	1.6	5.3	0	2.5

Alliant Engineering Inc Minneapolis, MN 55415

CSAH-62 at Baker Rd / CSAH-60
Ref.Pt.:
Alliant Engineering Inc
TURN MOVEMENT COUNT

File Name : 28_TH 62 at Baker Rd_030210
Site Code : 00000028
Start Date : 3/2/2010
Page No : 3

Start Time	Baker Rd (Co Rd 60) Southbound					CSAH-62 / W 62nd St Westbound					Baker Rd (Co Rd 60) Northbound					CSAH-62 / W 62nd St Eastbound					Int. Total
	Left	Thru	Right	Peds	App. Total	Left	Thru	Right	Peds	App. Total	Left	Thru	Right	Peds	App. Total	Left	Thru	Right	Peds	App. Total	
Peak Hour Analysis From 06:00 to 09:15 - Peak 1 of 1																					
Peak Hour for Entire Intersection Begins at 07:15																					
07:15	27	9	2	0	38	29	104	36	0	169	13	40	144	0	197	11	433	15	0	459	863
07:30	41	19	2	0	62	36	102	51	0	189	18	34	136	0	188	14	408	15	0	437	876
07:45	54	34	1	0	89	46	99	59	0	204	19	50	163	0	232	15	453	19	0	487	1012
08:00	23	21	4	0	48	56	128	83	0	267	15	34	121	0	170	6	317	14	0	337	822
Total Volume	145	83	9	0	237	167	433	229	0	829	65	158	564	0	787	46	1611	63	0	1720	3573
% App. Total	61.2	35	3.8	0		20.1	52.2	27.6	0		8.3	20.1	71.7	0		2.7	93.7	3.7	0		
PHF	.671	.610	.563	.000	.666	.746	.846	.690	.000	.776	.855	.790	.865	.000	.848	.767	.889	.829	.000	.883	.883

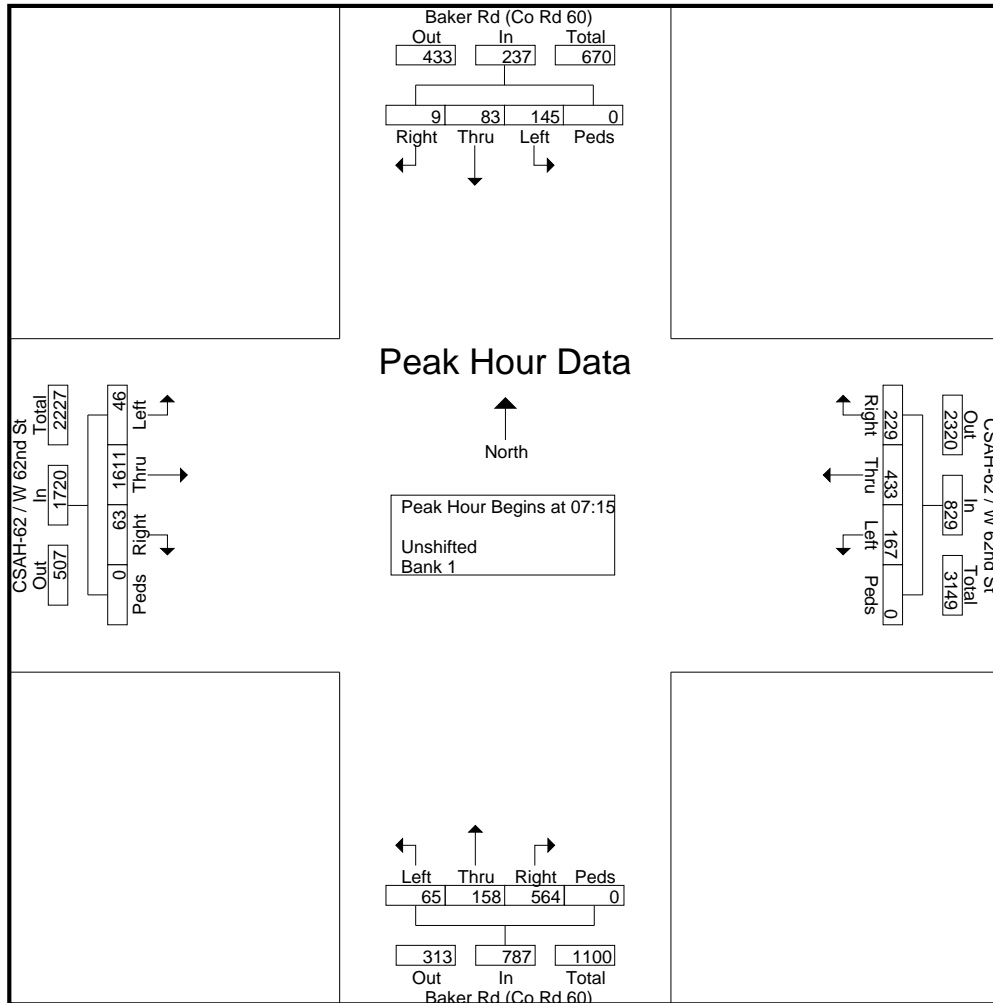

Alliant Engineering Inc Minneapolis, MN 55415

CSAH-62 at Baker Rd / CSAH-60
Ref.Pt.:
Alliant Engineering Inc
TURN MOVEMENT COUNT

File Name : 28_TH 62 at Baker Rd_030210
Site Code : 00000028
Start Date : 3/2/2010
Page No : 4

Start Time	Baker Rd (Co Rd 60) Southbound					CSAH-62 / W 62nd St Westbound					Baker Rd (Co Rd 60) Northbound					CSAH-62 / W 62nd St Eastbound					Int. Total
	Left	Thru	Right	Peds	App. Total	Left	Thru	Right	Peds	App. Total	Left	Thru	Right	Peds	App. Total	Left	Thru	Right	Peds	App. Total	
Peak Hour Analysis From 15:00 to 17:45 - Peak 1 of 1																					
Peak Hour for Entire Intersection Begins at 16:30																					
16:30	60	47	13	0	120	85	317	33	0	435	23	26	49	0	98	16	160	23	0	199	852
16:45	53	31	24	0	108	122	325	29	0	476	29	37	46	0	112	14	96	30	0	140	836
17:00	76	51	22	0	149	111	357	25	0	493	22	32	51	0	105	13	118	31	0	162	909
17:15	41	44	17	0	102	136	429	19	0	584	27	31	44	0	102	8	108	27	0	143	931
Total Volume	230	173	76	0	479	454	1428	106	0	1988	101	126	190	0	417	51	482	111	0	644	3528
% App. Total	48	36.1	15.9	0		22.8	71.8	5.3	0		24.2	30.2	45.6	0		7.9	74.8	17.2	0		
PHF	.757	.848	.792	.000	.804	.835	.832	.803	.000	.851	.871	.851	.931	.000	.931	.797	.753	.895	.000	.809	.947

